



RPMME

Homepage: <http://penerbit.uthm.edu.my/periodicals/index.php/rpmme>
e-ISSN : 2773-4765

Flexural and Tensile Properties of Different Aluminum Alloy Through Simulation Analysis

Farah Nur Arissa Muhammad Nizam¹, Sharifah Adzila Syed Abu Bakar^{1*}

¹Department of Engineering Mechanics, Faculty of Mechanical and Manufacturing Engineering,
Universiti Tun Hussein Onn Malaysia, 86400 Batu Pahat, Johor, MALAYSIA

*Corresponding Author Designation

DOI: <https://doi.org/10.30880/rpmme.2022.03.01.023>

Received 15 Nov. 2021; Accepted 15 April 2022; Available online 30 July 2022

Abstract: Metal alloy is a combination of pure metal with another material in order to improve its properties. The selection of pure metal and another materials depends on its application. In this research, different aluminum alloy will be used to conduct the simulation. Aluminum alloy was selected in this research because this metal alloy was widely used in industries. Therefore, the objective of this study are to identify the flexural and tensile properties of aluminum alloy with different type of aluminum alloy and to analyse the effect of different load in flexural and tensile testing through simulation analysis. The shape and dimension of sample according to ASTM E8. The samples were designed and analyzed in Solidwork software. The static simulation was selected for flexural and tensile testing. The parameter that obtain in Solidwork simulation is stress, strain and displacement. Moreover, the result of stress and strain was plotted in graph to obtain the flexural and tensile strength of samples. From the result, samples (AA2014, AA2024, AA3003, AA6061 and AA7079) with 5000 N of applied load had the highest value of flexural and tensile strength while samples (AA2014, AA2024, AA3003, AA6061 and AA7079) with 1000 N of applied load had the lowest value of flexural and tensile strength. Thus, the applied load was affected flexural and tensile strength meanwhile the type of aluminum did not affected the properties. There are some recommendation for future work. One of recommendation is validation of Solidwork simulation result by carried out an experiment. By doing experiment, we can compare the result obtain from simulation and the result will more accurate. Lastly, select a proper software for simulation. We must choose the correct software that can provide the output desired result.

Keywords: Metal Alloy, Aluminum Alloy, Flexural, Tensile, Solidwork

1. Introduction

Metallic materials are an inorganic substance and it will combine with small amount of non-metallic element such as carbon, nitrogen and oxygen [1]. Commonly, pure metal are rare to be used in industrial and the pure metal will combine with another material to form metal alloy [2]. The fabrication of metal alloy depends on the properties and application [3]. Moreover, metallic materials can be divided into two group which are non-ferrous and ferrous [1]. Example of ferrous alloy are steel and cast iron while example of non-ferrous alloy are aluminum alloy and titanium alloy [3].

Aluminum alloy was categorized in non-ferrous alloy [3]. The pure aluminum will combine with another material to form aluminum alloy [3]. It is because the pure aluminum easy to break at high temperature and it cannot durable for a long time [3]. By adding another material, the properties of aluminum alloy can be improve [2]. Each type of aluminum alloy depends on their properties and application [4]. The fabrication of aluminum alloy also depends on their application. Aluminum alloy can be divide into two groups which are wrought composition and cast composition. The two groups of aluminum alloy can be different by their primary mechanism of property development [4]. Next, cast and wrought designation had been develop to different the type of aluminum alloy and its groups [4]. Four digits system start with 1xxx to 9xxx for cast and wrought alloy [4]. The four digits system represent the treatments and alloys of aluminum.

For this study, different aluminum alloy were tested. Different type of aluminum alloy were undergoes flexural and tensile testing through Solidwork simulation. There were different load used in this experiment. The type of load according to the testing. By conducting this experiment, the properties of aluminum alloy can be proved through simulation analysis without conduct an experiment. This study will provided understanding of mechanical properties of aluminum alloy and create another ways to perform an experiment.

2. Materials and Methods

There were five different type of aluminum alloy in this experiment. The shape and dimension of samples were followed according to ASTM E8. Solidwork software was used to sketch and do simulation of sample.

2.1 Testing sample

There were five sample with different type of aluminum alloy. Each of samples had same dimension and shape according to ASTM E8. Table 2.1 shows the testing sample:

Table 2.1: Testing sample

Sample No	Type	Load (N)
1	Aluminum Alloy 2014	1000
	Aluminum Alloy 2024	
	Aluminum Alloy 3003	
	Aluminum Alloy 6061	
	Aluminum Alloy 7079	
2	Aluminum Alloy 2014	2000
	Aluminum Alloy 2024	
	Aluminum Alloy 3003	
	Aluminum Alloy 6061	
	Aluminum Alloy 7079	
3	Aluminum Alloy 2014	3000
	Aluminum Alloy 2024	
	Aluminum Alloy 3003	
	Aluminum Alloy 6061	
	Aluminum Alloy 7079	
4	Aluminum Alloy 2014	4000
	Aluminum Alloy 2024	
	Aluminum Alloy 3003	
	Aluminum Alloy 6061	
	Aluminum Alloy 7079	
5	Aluminum Alloy 2014	5000
	Aluminum Alloy 2024	
	Aluminum Alloy 3003	
	Aluminum Alloy 6061	
	Aluminum Alloy 7079	

2.2 Dimension of sample

The dimension of sample was on ASTM E8. There was one type of geometries with one dimension. Figure 2.1 and Table 2.2 shows the dimension of samples for both geometries:

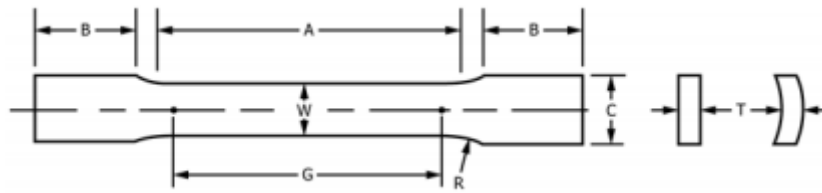

Figure 2.1: Plate-type sample [5]

Table 2.1 : Dimension of plate-type sample [5]

Sample	A
Gauge length, G (mm)	50.0
Width, W (mm)	12.5
Thickness, T (mm)	6.0
Radius of fillet, R (mm)	12.5
Length of reduced parallel section, A (mm)	60.0
Length of grip section, B (mm)	75.0
Width of grip section, C (mm)	20.0

2.3 Solidwork Software

Solidwork is a software that were used by designers to sketch out, produced models, doing simulation and details drawing [6]. Commonly, Solidwork was used to create a 3D product or object [6]. Figure 2.2 shows Solidwork software:

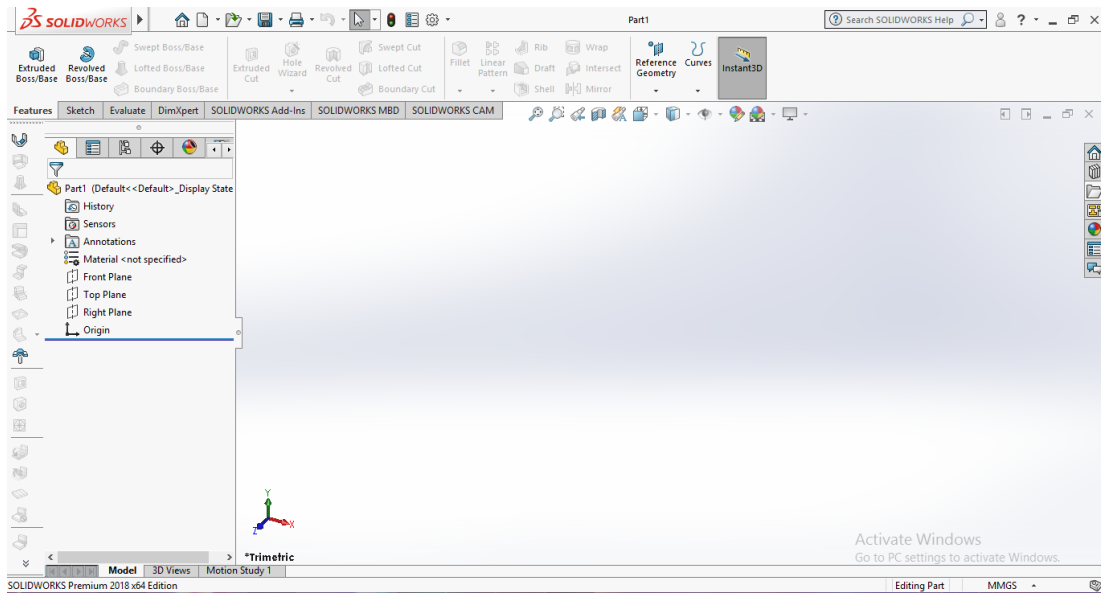

Figure 2.2: Solidwork software

There are component of Solidwork which are parts, assembly and drawing. The uses of part is to sketch the product or object while the uses of assembly is to assemble the component of product into one after the object become 3D. Figure 2.3 shows the Solidwork component:

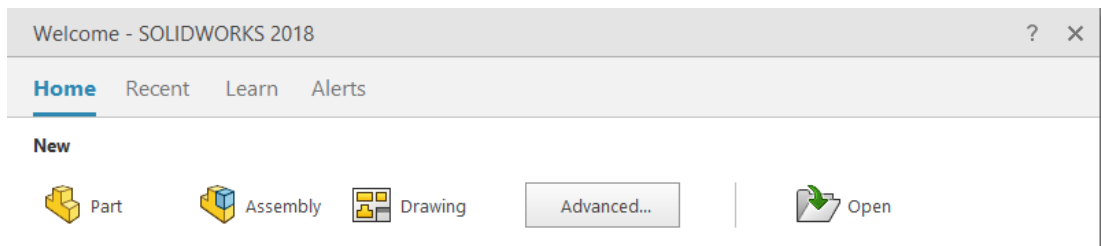

Figure 2.3: Solidwork component

When the part was selected, the right side of Solidwork have Planes. There were three type of planes which are front, top and right plane. Each of plane decided the position of product that had been sketch. Figure 2.4 shows the plane:

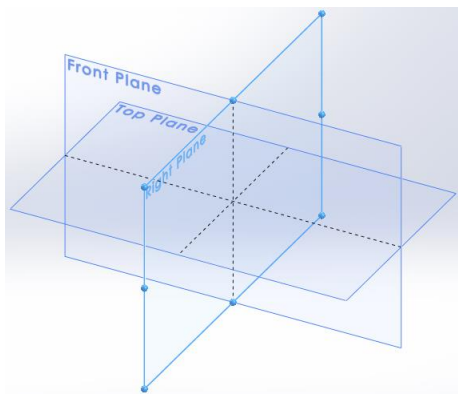

Figure 2.4: Planes of Solidwork

Moreover, Solidwork can do some simulation such as buckling, static and others. Each testing had different data needs to fill up. For example, static simulation needs to select the connection, fixture and external if related to project. Before run the simulation, we must select the material. All the materials are provided in Solidwork such as aluminum alloy, titanium alloy and others. We can create the new material if there no relevant material that we needs.

2.3 Theory performance

First of all, the sample had been drawn in Solidwork according to dimension in ASTM E8. The sample had been sketched in top plane for flexural testing and front plane for tensile testing. The position of sample was different. Figure 2.5 and Figure 2.6 shows the sketching of specimen:

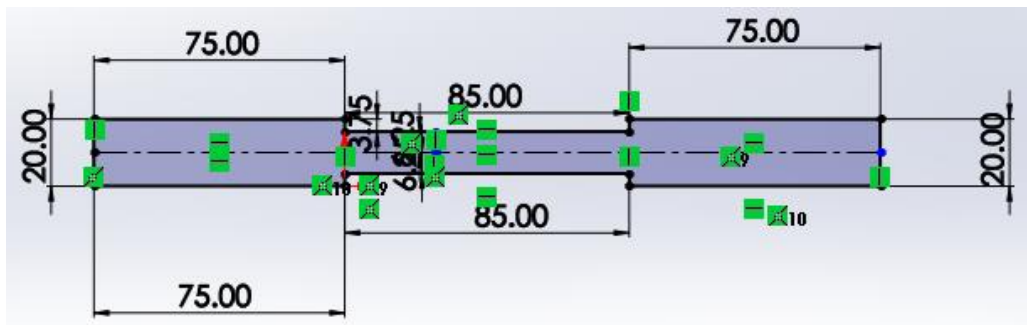

Figure 2.5: Sketching of flexural sample

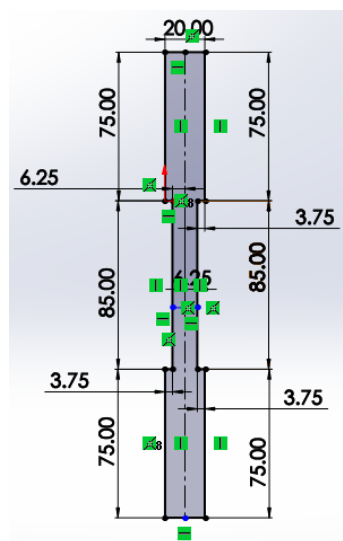

Figure 2.6: Sketching of tensile sample

After sketch, the sample was extruded according to 6 mm of thickness. Then, choose the fillet option to do the radius. Figure 2.7 and Figure 2.8 shows sample for both testing:

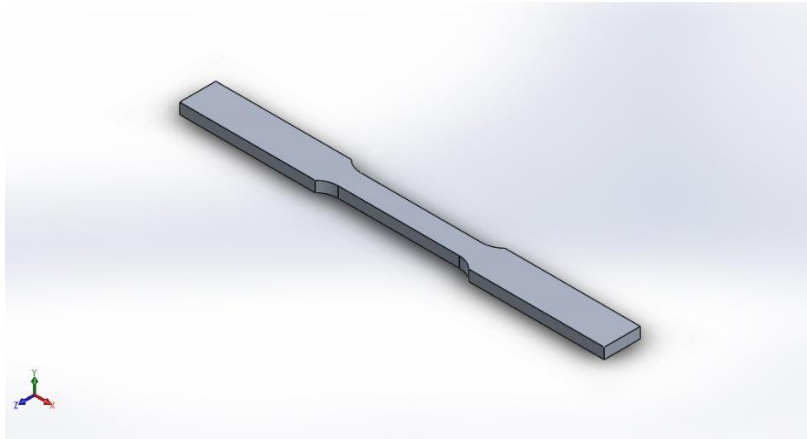

Figure 2.7: Samples of flexural testing

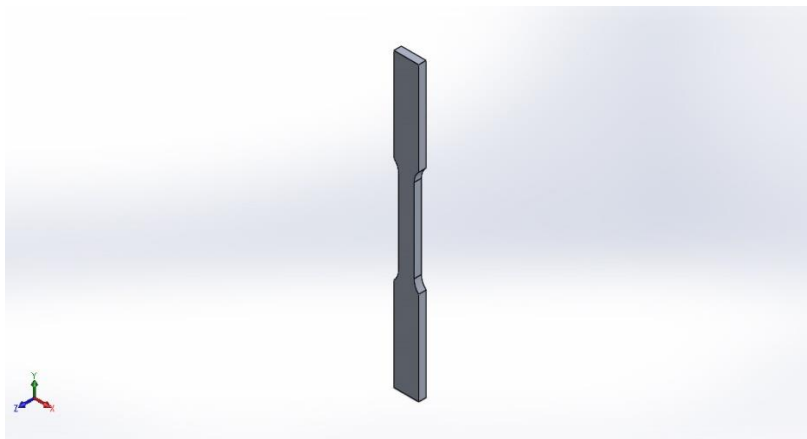

Figure 2.8: Samples of tensile testing

After that, Solidwork Add-Ins had been selected and the button of Solidwork simulation had been clicked to active the simulation. Then, click on new study and select the static simulation. In static simulation, there are component that we needs to be selected. Figure 2.9 shows the components of static simulation:

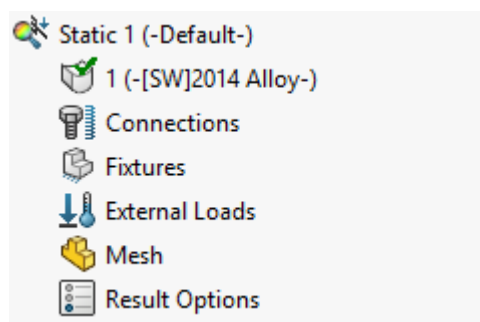

Figure 2.9: Components of static simulation

The fixed support on both sides and the load was applied at centre of samples for flexural testing while the fixed support on the bottom of samples and the direction of force on upward for tensile testing. Lastly, the samples were undergoes meshing and the simulation was run. The data that obtained from Solidwork are stress, strain and displacement. Figure 2.10 and Figure 2.11 shows the simulation for both testing:

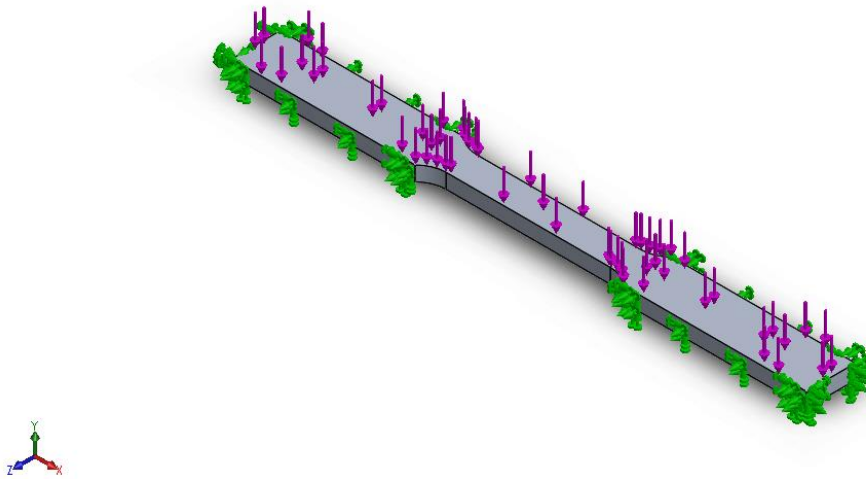

Figure 2.10: Flexural testing

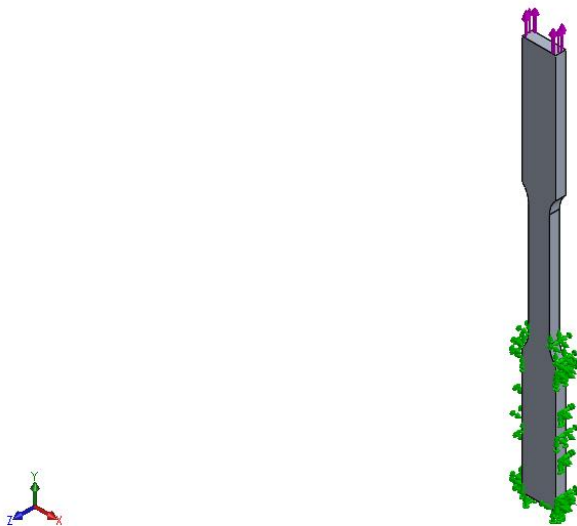

Figure 2.11: Tensile testing

3. Results and Discussion

3.1 Flexural strength

The position of load and fixed support was different. From the Solidwork simulation, the data of strain, stress and displacement were obtained. The data of stress and strain were plotted into graph. The flexural strength were obtained from maximum stress. Table 3.1 and Figure 3.1 shows the result of flexural testing:

Table 3.1: Result of flexural testing

Sample No	Type	Load (N)	Flexural strength (MPa)
1	Aluminum Alloy 2012	1000	44.23
	Aluminum Alloy 2024		
	Aluminum Alloy 3003		
	Aluminum Alloy 6061		
	Aluminum Alloy 7079		
2	Aluminum Alloy 2012	2000	84.47
	Aluminum Alloy 2024		
	Aluminum Alloy 3003		
	Aluminum Alloy 6061		
	Aluminum Alloy 7079		
3	Aluminum Alloy 2012	3000	132.70
	Aluminum Alloy 2024		
	Aluminum Alloy 3003		
	Aluminum Alloy 6061		
	Aluminum Alloy 7079		
4	Aluminum Alloy 2012	4000	176.90
	Aluminum Alloy 2024		
	Aluminum Alloy 3003		
	Aluminum Alloy 6061		
	Aluminum Alloy 7079		
5	Aluminum Alloy 2012	5000	221.20
	Aluminum Alloy 2024		
	Aluminum Alloy 3003		
	Aluminum Alloy 6061		
	Aluminum Alloy 7079		

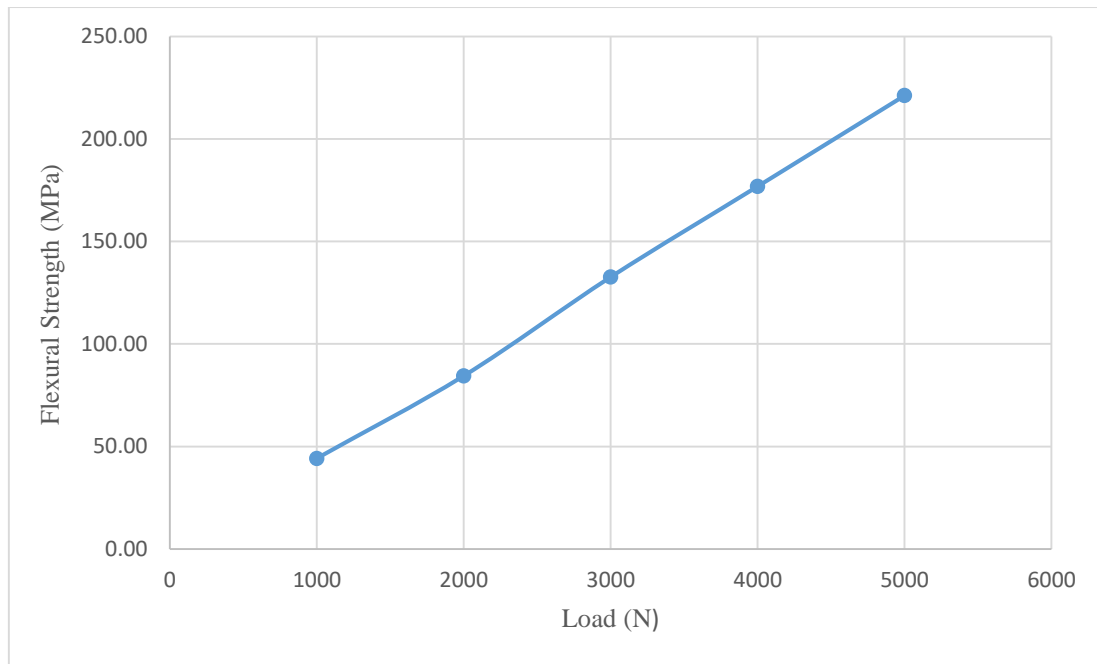

Figure 3.1: Flexural strength vs load graph

From Table 2.1, the different type of aluminum alloys does not affect the flexural strength of sample. It is because the properties of each sample almost same such as poisson ratio and mass density. The values of parameter for each aluminum alloys had been set in the Solidwork. In simulation analysis, the values obtained for flexural strength were same in all samples. Different load had been applied for five different samples. The highest value of flexural strength was samples at 5000 N load with the value of 221.20 MPa and the lowest value of flexural strength was samples at 1000 N load with the value of 44.23 MPa. When the load increase, the flexural strength were also increase. Therefore, it can be concluded that different type of aluminum alloys does not affect the flexural strength but load that applied on sample will affect the flexural properties.

Based on previous study, flexural strength was conducted on aluminum alloy 6061 with different composition [7]. The dimension and shape of specimen were according to ASTM A:370. The flexural strength for aluminum alloy 6061 is 299.71 MPa. This experiment was conducted until the specimen deformed [7]. However, in Solidwork simulation at 5000 N of maximum load applied, the flexural strength was 221.20 MPa. At 5000 N of load, the flexural strength was maximum. There was a slightly different between the value of maximum flexural strength in simulation with the value obtained from the previous research. This is because the load was limited for 5000 N in simulation and there was no further load applied to the samples until it deformed.

Aluminum alloy 6061 was most popular in previous studies. This aluminum alloy contain silicon and magnesium. It also undergoes heat treatment. Besides, aluminum alloy 6061 had good formability, weldability and corrosion resistance [4]. Due to this properties, aluminum alloy 6061 was used in automotive and aircraft industries.

3.1 Tensile strength

There were a fixed support on downward of sample and the force were applied at the top of sample. In Solidwork simulation, the data of stress, strain and displacement were obtained. The data of stress and strain were used to plot the stress-strain graph. Tensile strength were obtained from maximum stress. Table 3.2 and Figure 3.2 shows the result of tensile testing:

Table 3.2: Result of tensile testing

Sample No	Type	Load (N)	Tensile strength (MPa)
1	Aluminum Alloy 2012	1000	31.70
	Aluminum Alloy 2024		
	Aluminum Alloy 3003		
	Aluminum Alloy 6061		
	Aluminum Alloy 7079		
2	Aluminum Alloy 2012	2000	62.94
	Aluminum Alloy 2024		
	Aluminum Alloy 3003		
	Aluminum Alloy 6061		
	Aluminum Alloy 7079		
3	Aluminum Alloy 2012	3000	94.41
	Aluminum Alloy 2024		
	Aluminum Alloy 3003		
	Aluminum Alloy 6061		
	Aluminum Alloy 7079		
4	Aluminum Alloy 2012	4000	125.90
	Aluminum Alloy 2024		
	Aluminum Alloy 3003		
	Aluminum Alloy 6061		
	Aluminum Alloy 7079		
5	Aluminum Alloy 2012	5000	157.40
	Aluminum Alloy 2024		
	Aluminum Alloy 3003		
	Aluminum Alloy 6061		
	Aluminum Alloy 7079		

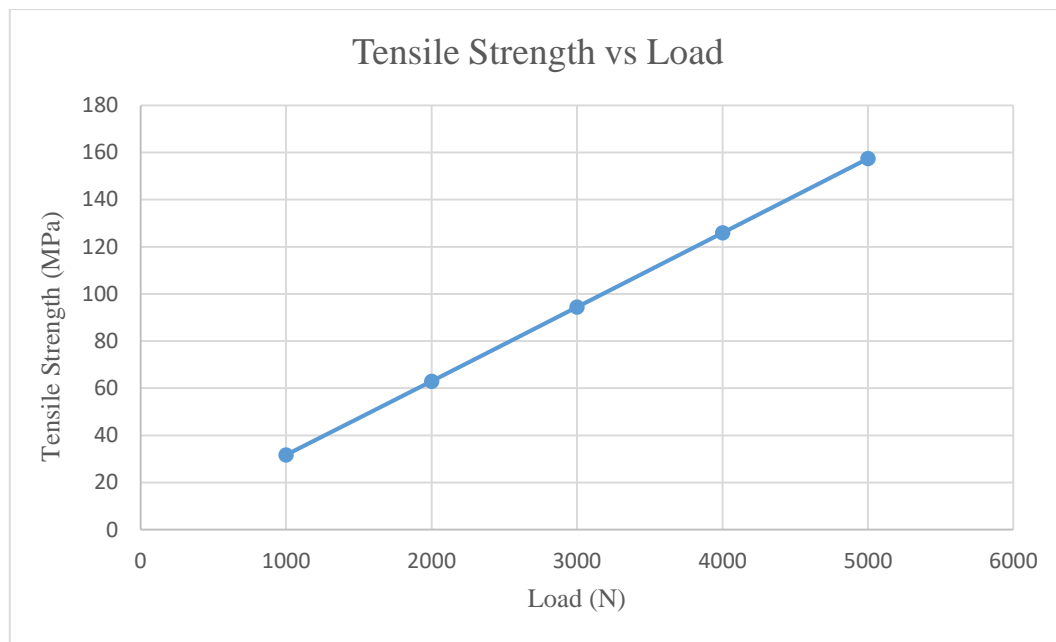

Figure 3.2: Tensile strength vs load graph

The type of aluminum alloy does not affect the tensile strength in simulation. One of the factor that the type of aluminum alloy does not affect tensile strength is the properties of each aluminum alloy almost same to each other. The properties of aluminum alloy had been set in Solidwork when select the material. The highest value of tensile strength is 157.40 MPa at 5000 N load and the lowest value of tensile strength is 31.70 MPa at 1000 N load. When the load increase, the tensile strength were increase. It can been concluded that the load that applied on samples will affect the tensile strength meanwhile the type of aluminum alloy did not affect the tensile strength.

The study of Sinhmar & Dwivedi (2019) was conduct an experiment of mechanical and corrosion behaviour of friction stir weld joint of aluminum alloy. In this experiment, the researcher used aluminum alloy 2014 and the samples was undergoes friction stir welding [8]. The tensile strength that was obtained in this experiment is 300 MPa. However, the highest tensile strength in simulation was 157.40 MPa. There were significant different between tensile strength of experimental and simulation. Other than that, Tan et al. (2017) was conduct an experiment of microstructure and mechanical properties of AA 3003 aluminum alloy joint by underwater friction stir welding. The samples undergoes hot band and annealed hot band process. The highest tensile strength was 156.90 MPa in hot band [9]. The highest tensile strength in simulation is 157.40 MPa. There were slightly different between tensile strength of previous experiment and simulation analysis. Lastly, the study of Ramesh et al. (2009) was conduct an experiment of aluminum alloy 6061 by using different composition. The configuration of samples according to ASTM E8-82. The samples was prepared by vortex method [10]. In this experiment, the tensile strength is 153.90 MPa. However, the highest tensile strength of simulation analysis is 157.40 MPa. There were slightly different between the result of tensile strength in previous experiment with simulation analysis. From the previous studies, it can be concluded that the fabrication and configuration of sample were affect the tensile strength.

4. Conclusion

This study was carried out to achieve the objective which are to identify the flexural and tensile tensile properties of aluminum alloy by using different type of aluminum alloy through simulation analysis and to analyse the effect of different load were applied on both properties through simulation analysis. The dimension and shape of sample according to ASTM E8. The software that was used to run the simulation is Solidwork software. Before run the simulation, the samples were sketching in

Solidwork. After that, the samples were undergoes simulation. The data of strain, stress and strain were obtained in the simulation. It can be concluded that the type of aluminum alloy does not affect the flexural and tensile properties of specimen but load applied in both testing were affect the properties. The highest values of flexural and tensile strength at 5000 N load while the lowest values of flexural and tensile strength at 1000 N load.

There are some recommendation that needs in this study in order to improve it. One of the recommendation is the validation of Solidwork result by carried out an experiment. This will ensure more accurate result and the values of simulation analysis can be compare with the values of experimental. Next, select the proper software to make the work easily. When run the testing in simulation, the selected software must provide the output desired data. It will save some time to extract the data. When doing the mechanical testing in simulation, choose the different group materials to avoid the same data obtained. Some of the software had set up the properties of material when select the material. The value of properties might be same.

Acknowledgement

The authors would like to thank the Faculty of Mechanical and Manufacturing Engineering, Universiti Tun Hussein Onn Malaysia for its support.

References

- [1] S. Mridha, "Metallic Materials," *Ref. Modul. Mater. Sci. Mater. Eng.*, pp. 1–7, 2016, doi: 10.1016/b978-0-12-803581-8.04097-2.
- [2] E. J. Minay and A. R. Boccaccini, "Metals," *Biomater. Artif. Organs Tissue Eng.*, pp. 15–25, 2017, doi: 10.1533/9781845690861.1.15.
- [3] K. Basuki, "Metals," *ISSN 2502-3632 ISSN 2356-0304 J. Online Int. Nas. Vol. 7 No.1, Januari – Juni 2019 Univ. 17 Agustus 1945 Jakarta*, vol. 53, no. 9, pp. 1689–1699, 2019, [Online]. Available: www.journal.uta45jakarta.ac.id.
- [4] M. Ozesmi, T. E. Patiroglu, G. Hillerdal, and C. Ozesmi, "Aluminum and Aluminium Alloy," *Br. J. Ind. Med.*, vol. 42, no. 11, pp. 746–749, 2018, doi: 10.1136/oem.42.11.746.
- [5] ASTM E8, "ASTM E8/E8M standard test methods for tension testing of metallic materials 1," *Annu. B. ASTM Stand.* 4, no. C, pp. 1–27, 2010, doi: 10.1520/E0008.
- [6] SolidWorks, "INTRODUCING SOLIDWORKS Contents," *Dassault Systèmes SolidWorks*, p. 128, 2015.
- [7] M. Satheesh and M. Pugazhvadivu, "Flexural Strength Behavior of Al 6061matrix Reinforced with SiC and Coconut shell ash," *SSRG Int. J. Mech. Eng. (SSRG-IJME)-Special Issue*, pp. 12–15, 2018, [Online]. Available: <http://www.internationaljournalsrrg.org>.
- [8] S. Sinhmar and D. K. Dwivedi, "Investigation of mechanical and corrosion behavior of friction stir weld joint of aluminium alloy," *Mater. Today Proc.*, vol. 18, pp. 4542–4548, 2019, doi: 10.1016/j.matpr.2019.07.426.
- [9] Y. B. Tan *et al.*, "A study on microstructure and mechanical properties of AA 3003 aluminum alloy joints by underwater friction stir welding," *Mater. Charact.*, vol. 127, pp. 41–52, 2017, doi: 10.1016/j.matchar.2017.01.039.
- [10] A. Ramesh, J. N. Prakash, A. S. S. S. Gowda, and S. Appaiah, "Comparison of the Mechanical Properties of AL6061/Albite and AL6061/Graphite Metal Matrix Composites," *J. Miner. Mater. Charact. Eng.*, vol. 08, no. 02, pp. 93–106, 2009, doi: 10.4236/jmmce.2009.82009.