

Smart Cooling Water Container with IoT

Mohamad Hazim Kamarol Zaman¹, Megat Satria Zainuddin^{1*}

¹ Department of Electrical Engineering Technology, Faculty of Engineering Technology,
Universiti Tun Hussein Onn Malaysia, Pagoh, 84600, Muar, Johor MALAYSIA

*Corresponding Author: megat@uthm.edu.my

DOI: <https://doi.org/10.30880/peat.2024.05.02.003>

Article Info

Received: 27 June 2024

Accepted: 18 July 2024

Available online: 25 November 2024

Keywords

Hydration, IoT, Cooling, ESP-32,
Health, Remote, Blynk, Temperature,
Thermoelectric, Water, Control

Abstract

This project aims to develop a smart cooling water container leveraging IoT (Internet of Things) technology to enhance hydration by maintaining optimal water temperature. The core of the system is the ESP32 microprocessor, which interfaces with various components to ensure precise thermal regulation and user convenience. Key inputs include the Temperature Control XH-W3001, which sets the desired temperature, and the DHT11 Humidity and Temperature Sensor, which continuously monitors the container's internal environment. The ESP32 processes this data and interacts with output components such as an OLED display for real-time feedback, a Blynk module for remote control and monitoring via a smartphone app, and cloud storage for data processing and accessibility. Additionally, a water pump ensures even cooling, while a Peltier module provides the thermoelectric cooling necessary to maintain the set temperature. The integration of these components facilitates a seamless and user-friendly experience, allowing users to remotely adjust settings, receive notifications about their hydration levels, and monitor the water temperature. This project also emphasizes eco-friendly practices by utilizing thermoelectric cooling, which eliminates the need for traditional refrigerants. The anticipated results include a reliable and efficient cooling system that enhances hydration by keeping water at an optimal temperature, thereby encouraging regular water intake and improving overall health. Additionally, the project aims to demonstrate the practical application of IoT in everyday objects, potentially leading to further innovations in smart home and personal health technologies.

1. Introduction

Water is essential for life, playing a critical role in the survival and health of many species, including humans [1]. Proper hydration, which involves providing the body with an adequate amount of water, supports various physiological functions [1]. Water is vital for processes such as nutrient absorption, temperature regulation, and waste elimination, accounting for 75% of body weight in babies and 55% in the elderly [2]. Maintaining the balance of bodily fluids through proper hydration aids digestion, circulation, nutrient transport, and temperature maintenance. Insufficient hydration can lead to health issues such as headaches, fatigue, and severe cases of heat stroke or kidney problems. Recommended daily water intake varies, generally around 3.7 liters for men and 2.7 liters for women, but these needs can increase with factors like physical activity and climate [3-7]. Hydration also impacts cognitive function, mood, and skin health.

The development of a cooling water container with IoT functionality aims to address the limitations of traditional water-cooling methods, enhancing user convenience through technology. Current methods, like

refrigeration and insulated bottles, have drawbacks, especially for those constantly on the move or in extreme conditions. The proposed smart container offers a consistent cooling function, remotely controlled and monitored via a smartphone app, allowing users to adjust the temperature, receive notifications, and track hydration levels. This innovative solution would be particularly beneficial for individuals in hot climates, athletes, and outdoor professionals. However, challenges such as ensuring efficient thermal insulation, portability, battery life, and user-friendly app design must be addressed for successful implementation. If these challenges are overcome, this project could significantly improve hydration management, combining convenience, technology, and health benefits.

2. Literature Review

2.1 Water and Hydration

Hydration is crucial for athletic performance and outdoor activities, affecting physical capabilities and overall health. Whether you're an athlete, recreational sports enthusiast, or adventurer, maintaining optimal hydration is essential. A key question is whether cold or warm water is more effective for hydration. This topic has sparked interest in the scientific community and among health enthusiasts, leading to various studies. Water temperature can impact the rate of hydration and overall comfort during physical activities. This introduction sets the stage for exploring these studies and examining the physiological effects, environmental impacts, and performance outcomes related to water temperature and hydration.

2.1.1 Effect of Water Temperature in Dehydrated Individuals.

In 2013, Abdollah Hosseinlou, Saeed Khamnei, and Masumeh Zamanlu conducted a study on how water temperature and voluntary drinking affect post-rehydration sweating in dehydrated individuals [8]. They found that drinking increased sweating quickly, but this response was slower with cold water at 5°C. The highest voluntary intake was with cool water at 16°C, which also resulted in a lower sweating response, suggesting this temperature is optimal for hydration. Conversely, cold water at 5°C led to the lowest intake and sweating response, indicating it may be less effective for rehydration. The study concludes that cool water at 16°C is most effective for rehydration, balancing intake and sweating.

2.1.2 Drinking Cold and Room Temperature Water During Exercise Session

In 2012, Danielle LaFata, Amanda Carlson-Phillips, Stacy T. Sims, and Elizabeth M. Russell studied the impact of cold (4°C) versus room temperature (22°C) water on core temperature and performance during a 60-minute exercise session combining strength and cardiovascular training in fit male participants [9]. They found that cold water significantly reduced the rise in core body temperature compared to room temperature water. However, this thermoregulation did not lead to improved performance, as there were no significant differences in broad jump and time to exhaustion tests. Participants even performed fewer bench press repetitions when drinking cold water. The researchers suggest that the benefits of cold water may be more apparent in more stressful environments or longer exercise durations. The study shows that while cold water helps manage core temperature, its effect on performance needs further investigation.

2.1.3 Thermoelectric Cooler

Thermoelectric cooling (TEC) devices, also known as Peltier devices, operate on the Peltier effect become the creation of a heat flux when an electrical current is passed through the junction of two different materials [10]. A thermoelectric cooler utilizes the Peltier effect to create a temperature difference between its two sides. At the core of the TEC are alternating n-type and p-type semiconductor materials arranged between two conductive plates [11]. When an electric current is applied across the TEC, it causes heat to be absorbed on one side of the device and released on the opposite side. This is due to the Peltier effect, which occurs at the junctions between the n-type and p-type semiconductors. As the current flows through these junctions, it transports heat from one side to the other, creating a temperature differential. The side where heat is absorbed becomes the cold side, while the side where heat is released becomes the hot side as shown in Figure 1. To maintain this temperature difference, the hot side of the TEC is connected to a heat sink, which helps dissipate the accumulated heat.

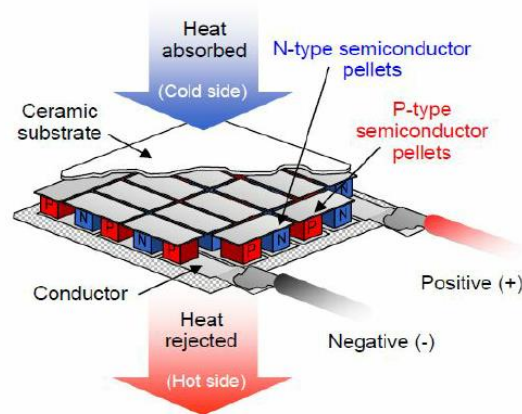

Fig.1 Thermoelectric cooler

2.2 Application of Peltier related with cooling method

In May 2023, Shorup Chanda, Riyan Hashem Jamy, and Md Hasibul Islam developed an air conditioner using a thermoelectric module (Peltier) and locally available components [13]. Their design process, which included selecting the Peltier module, fins, fan motor, electrical circuit, and pump, was initially created in SolidWorks. They used the Peltier-Thermoelectric Cooler Module Calculator by TE Technology to select the appropriate module, considering economic factors for manufacturing [13]. This foundational work highlights the practical application of Peltier modules in thermal management systems and emphasizes the importance of integrating local components and cost-effective manufacturing, which is directly relevant to our project of developing a cooling water container with IoT capabilities.

In a previous study from May 2016, Mudavath Baburam designed a compressor-less Peltier refrigerator with a 3.45 cubic meter cooling volume, featuring an on/off control system that achieved precise temperature regulation [14]. Testing showed the system could cool water from room temperature to -5 degrees Celsius, demonstrating the effectiveness of simple control mechanisms with Peltier modules [14]. Additionally, in 2021, B. Sandeep's team developed a portable mini refrigerator using Peltier modules for eco-friendly cooling. Their project aimed to create a refrigerator that could be installed in vehicles or organizational settings, offering an affordable and sustainable solution. These studies inform our project by showcasing the feasibility and advantages of using Peltier modules for efficient, practical, and eco-friendly cooling solutions, aligning well with our goal of creating a smart cooling water container.

2.3 Water Cooling Compared to Air Cooler

Cooling systems are extensively utilized in the process industry, typically categorized into air cooling and water cooling. While each type of cooling has its distinct advantages, the consumption of resources, particularly energy and water, is essential for sustaining system functionality. Considering the significant challenges in the industry, including energy and water conservation, careful consideration of resource consumption and economic impact is crucial when choosing a cooling system [15].

According to article published by CriticalCxE in 2024, one of the key advantages of liquid cooling over traditional air cooling is that it results in less clutter and more available space inside the electronic case [16]. Air cooling systems typically require multiple fans installed throughout the case to draw air in and expel heat, whereas a liquid cooling setup only requires a few components like the pump and radiator. Additionally, liquid cooling systems tend to operate more quietly compared to the noise generated by multiple fans in an air-cooled system, especially when electronic components are under heavy workloads [16]. The article also mentions that liquid cooling can provide better overclocking potential, as the more efficient heat dissipation allows the processor to be pushed to higher frequencies without overheating.

The article outlines several disadvantages of liquid cooling systems compared to air cooling [16]. Firstly, the initial setup cost for a liquid cooling system is considerably higher than a standard air cooling solution. There is also a higher level of complexity involved in installing a liquid cooling system, as it requires an understanding of electronics and thermodynamics. Additionally, liquid cooling systems carry the risk of leaks, which can lead to corrosion of metal components and damage to electronic parts if the coolant escapes [16]. The article emphasizes that proper implementation is crucial to ensure effective heat removal and prevent such leaks, which can be a concern for users unfamiliar with liquid cooling systems.

In 2023, Kristoffer Bonheur state in an article about Advantages and Disadvantages of Liquid Cooling. The article outlines several key disadvantages of water-cooling compared to traditional air cooling for computers and

devices [17]. Firstly, liquid cooling systems are significantly more expensive to implement. Additionally, setting up a liquid cooling system requires a deeper understanding of electronics and thermodynamics, making the installation process more complicated. Maintaining and upgrading a liquid cooling system also poses challenges. Finally, the article highlights the risk of leakage in liquid cooling systems, which can lead to corrosion of electronic components and potential damage to the device, making it a less reliable option for the average user compared to the more straightforward and safer air-cooling approach [17].

3. Materials and Method

3.1 Project Operation Flowchart

The flowchart for the smart cooling water container project as shown in Figure 2 illustrates a streamlined process for maintaining optimal water temperature using IoT technology. It begins with powering up and initializing the system, ensuring all components are ready for operation. The first decision point, "Power On?", checks if the system is activated; if not, it remains in an "OFF State" to conserve power until remotely turned on via a mobile app.

Once powered on, the ESP32 microcontroller manages data and communication tasks, working with the Temperature Controller XH-W3001 to set and maintain the desired water temperature. The "System Start/Stop" decision point determines if the cooling process should begin. If so, the system starts cooling, with real-time temperature data sent to an OLED display for user feedback. Integration with the Blynk platform allows for remote monitoring and control via a smartphone app, communicating with the cloud for data storage and processing. Throughout, the current temperature is continuously displayed, ensuring users are informed of the system's performance, while the system actively monitors and adjusts to maintain optimal hydration conditions.

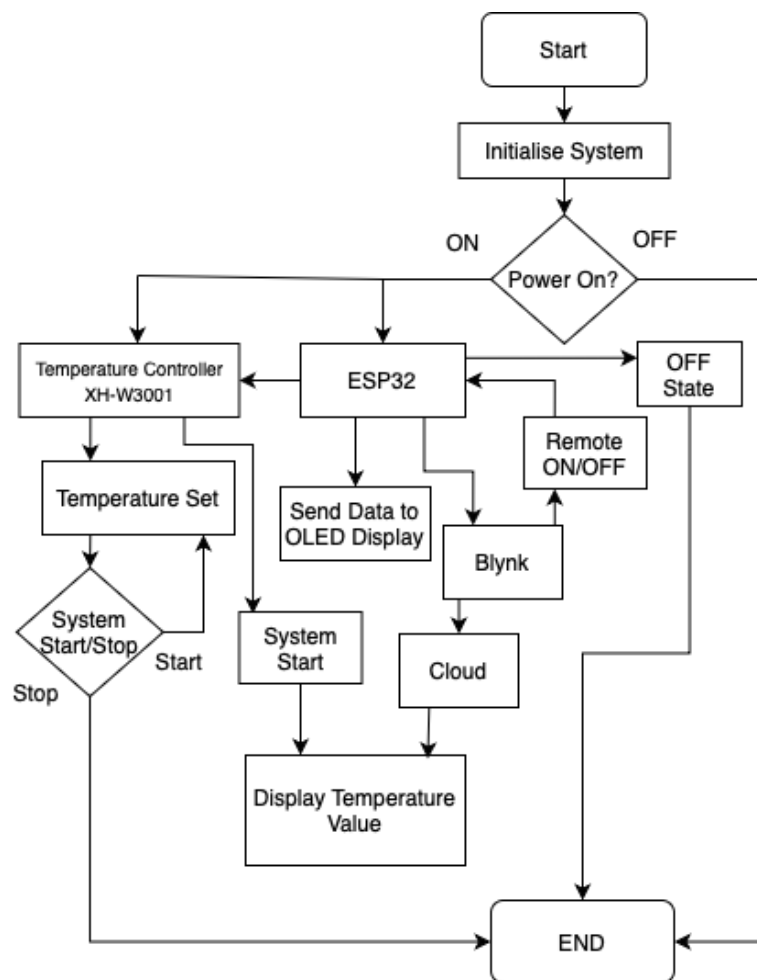

Fig. 2 Overall Project Operation Flowchart

3.2 Project Block Diagram

The block diagram for the smart cooling water container project as shown in Figure 3 outlines the key components and their interactions, with the ESP32 microprocessor at its core. The ESP32 manages all control and

communication functions, interfacing with the Temperature Control XH-W3001 and DHT11 Humidity and Temperature Sensor to gather crucial data for temperature regulation.

This data is processed by the ESP32 and communicated to several output components: the OLED Display for real-time visual feedback, the Blynk module for remote monitoring and control via a smartphone app, and the Cloud for data storage and processing. Additionally, the Water Pump is controlled by the ESP32 to manage water flow, and the Peltier module handles the cooling process. This integrated system ensures effective temperature management and user convenience, promoting optimal hydration through advanced IoT capabilities.

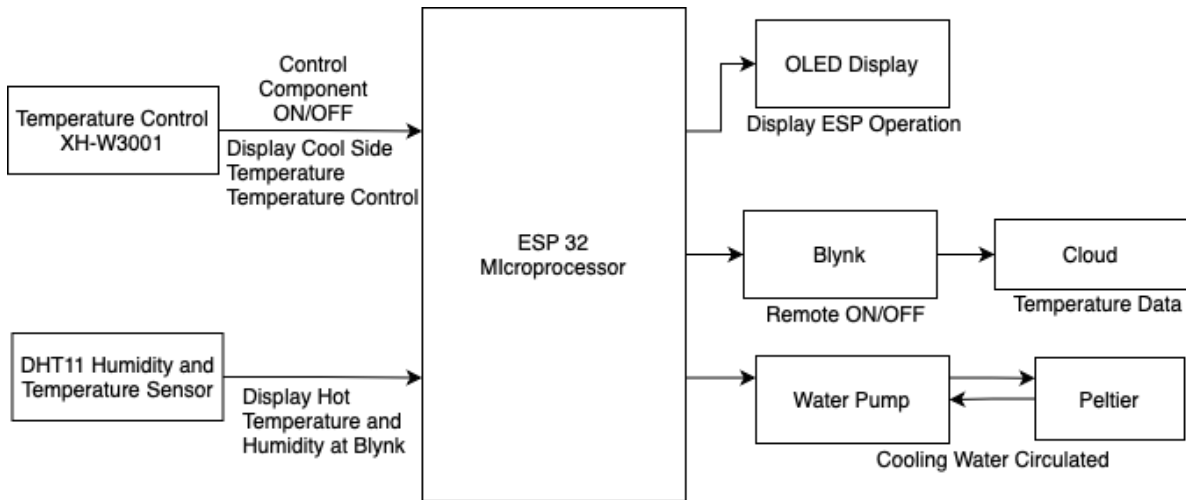

Fig. 3 Project Block Diagram

3.3 Hardware Development

3.3.1 Circuit Configuration

In any engineering project, the circuit configuration plays a pivotal role in determining the functionality, efficiency, and reliability of the system. In this project, It involves the strategic arrangement of electrical components with only limited space but can fill all the components for the system as shown in Figure 4. Proper circuit configuration ensures optimal current flow, voltage distribution, and signal integrity, which are crucial for the performance of this project prototype. The design of the prototype configuration must meet specific project requirements, adhering to safety standards and addressing potential issues like signal interference, thermal management, and power consumption. This meticulous process not only enhances the effectiveness of the project but also extends the lifespan of the components and the overall system.

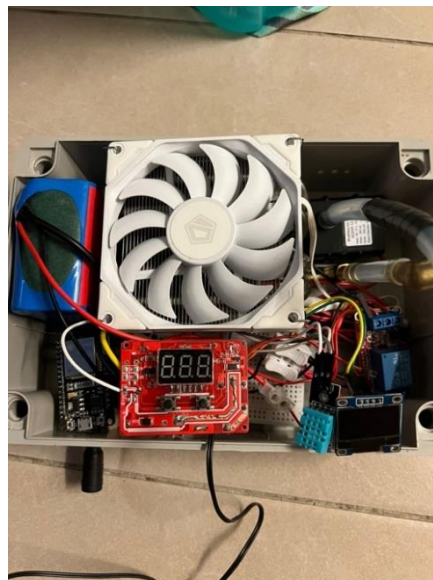

Fig 4 Project Circuit Configuration

3.3.2 Assembling the Components into one Prototype

The methodology for assembling the IoT-based water-cooling container prototype involved a systematic integration of hardware and software components. First, the ESP32 microcontroller was configured to connect to Wi-Fi and communicate with the Blynk app for remote monitoring and control. The DHT11 sensor was connected to the ESP32 to provide real-time temperature and humidity readings. A HW-803 relay module was used to control the power supply to the XH-W3001 temperature controller, which managed the cooling components including a fan, peltier module, and water pump. The relay was connected to GPIO 14 of the ESP32, allowing it to act as a master switch controlled via the Blynk app. The OLED display was also integrated to provide local status updates. A DC-DC converter was used to step down the 12V battery supply to a safe voltage for the ESP32. The components were mounted securely in a container, ensuring proper insulation and heat dissipation, and wired according to the schematic to ensure reliable operation. This careful assembly ensured that all components worked together seamlessly to achieve efficient cooling and remote manageability as shown in Figure 5.

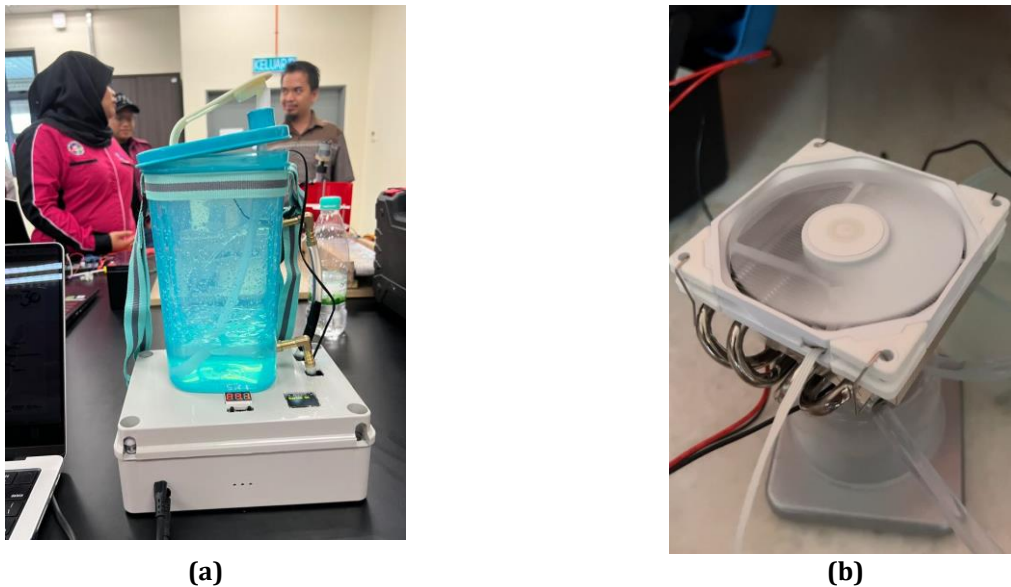

Fig. 5 Finished prototype (a), Component testing before assembling (b)

4. Result and Discussion

The purpose of this chapter is to make an analysis and discussion about the project. It involves the successful development and implementation of an IoT-enabled cooling water container using a Peltier module, demonstrating precise temperature control and effective cooling performance. The discussion will likely focus on the efficiency of the Peltier module in maintaining the desired temperature range, the reliability of the IoT system in monitoring and regulating the cooling process, and the overall practicality of the design in real-world applications.

4.1.1 Real-time Data Monitoring and Control

In this project, the Blynk platform plays a crucial role in providing remote monitoring and control of the smart cooling system. The ESP32 microcontroller is connected to Wi-Fi and communicates with the Blynk app using the Blynk library. This setup allows real-time transmission of temperature and humidity data from the DHT11 sensor to the Blynk app, enabling users to monitor environmental conditions on their smartphones. Additionally, a virtual switch in the Blynk app allows users to remotely control a relay connected to the ESP32, which acts as a master switch to power the XH-W3001 temperature controller and its connected 12V components such as fans, a peltier module, and a water pump as shown in Figure 6. This integration ensures that users can easily manage the cooling system from anywhere with internet access, enhancing both convenience and functionality.

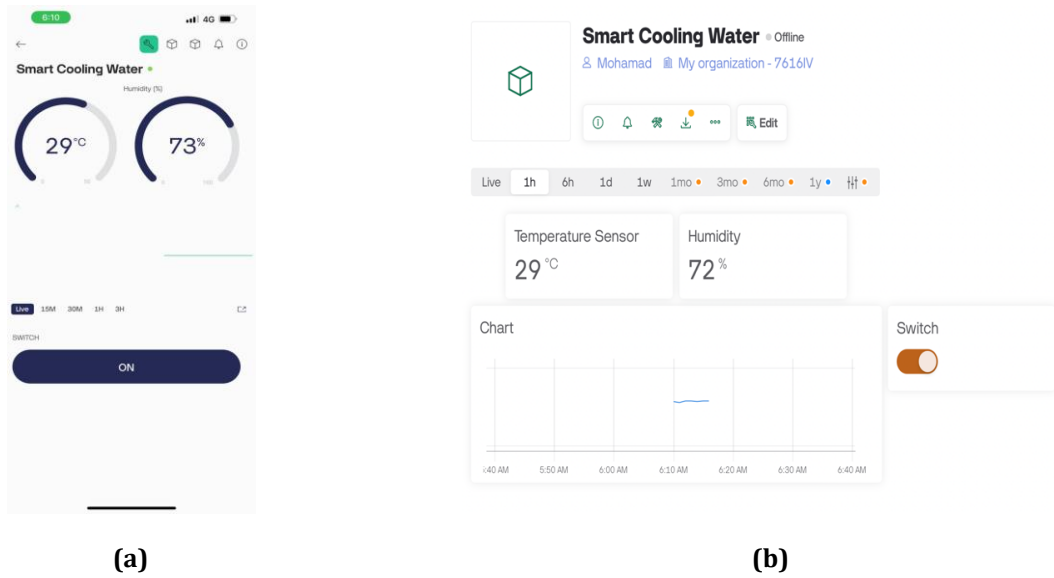

Fig. 6 Blynk interface at smartphone app (a), Blynk interface at Blynk website (b)

4.1.2 Relationship between Thermal Equilibrium and Water Temperature

Thermal equilibrium is a fundamental concept in thermodynamics where objects in thermal contact reach a uniform temperature, ceasing to exchange heat. In the context of water cooling with a Peltier module, thermal equilibrium determines heat distribution [18-19]. Initially, the Peltier module effectively reduces the water temperature from 27.1°C to 25.0°C in the first 20 minutes due to a significant temperature differential, showcasing its high efficiency. Between 20 and 65 minutes, the cooling rate slows as the temperature differential narrows, decreasing to 23.0°C. By 105 minutes, the temperature stabilizes at 22.4°C, indicating thermal equilibrium where the heat removal by the Peltier module matches the heat input, achieving a steady state as shown in Fig. 7.

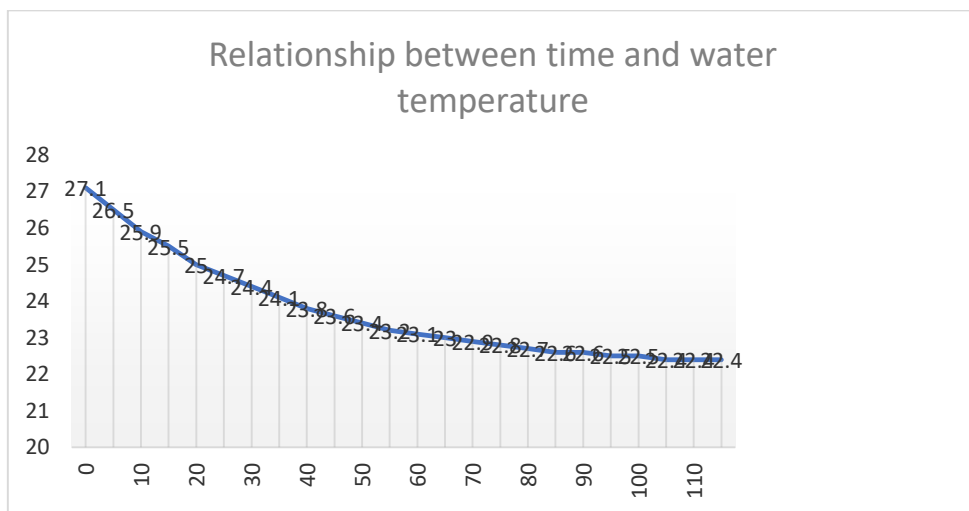

Fig. 7 Graph relationship between time and water temperature

These results highlight the Peltier module's initial rapid cooling capability and gradual efficiency decline as equilibrium is approached. The data suggests that for applications needing lower stable temperatures or faster cooling, additional measures such as better insulation or multiple Peltier modules may be necessary. The project underscores the potential of Peltier modules for eco-friendly, maintenance-free cooling systems, and points to areas for design improvements, like optimizing thermal interfaces and heat dissipation, to enhance performance and efficiency.

4.2 Relationship between Thermal Equilibrium with Water Volume

In this experiment, the different volumes of water (800ml and 400ml) is investigated over time using a thermoelectric cooler (TEC-12705). The goal was to observe how the water's temperature changed at regular intervals and to understand the impact of volume on the cooling process. The data reveals that the smaller volume

of water (400ml) cools more quickly and stabilizes at a lower equilibrium temperature compared to the larger volume (800ml) as shown in Fig. 8.

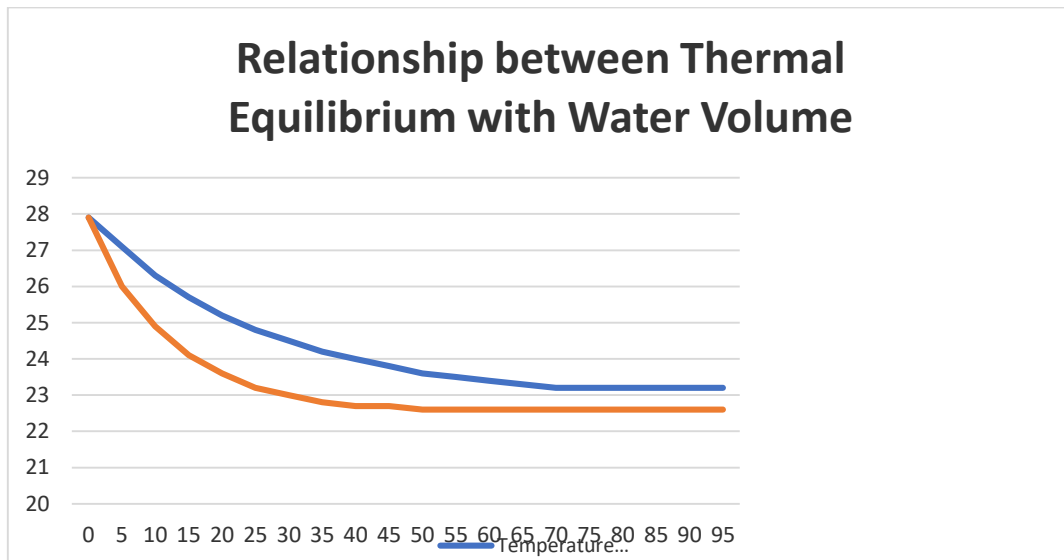

Fig. 8 Graph relationship between thermal equilibrium with water volume

Thermal equilibrium is reached when two systems in thermal contact no longer exchange heat, resulting in a uniform temperature. The thermoelectric cooler (TEC-12705) operates by creating a temperature difference, which drives heat from the water to the cooler until equilibrium is achieved [20].

Heat capacity is a crucial factor in understanding the cooling process. It is the amount of heat energy required to change the temperature of a substance by a given amount. Larger volumes of water, like the 800ml sample, have a higher heat capacity. This means they can store more thermal energy, requiring more energy to be removed to achieve the same temperature drop as a smaller volume. Consequently, the larger volume of water cools more slowly because the thermoelectric cooler must work harder to extract the greater amount of stored heat.

The surface area to volume ratio significantly influences the rate of heat transfer. A smaller volume of water typically has a higher surface area to volume ratio, enhancing its ability to dissipate heat more efficiently. In this experiment, the 400ml sample cooled faster than the 800ml sample due to its higher surface area relative to its volume. This allows the thermoelectric cooler to remove heat more effectively, leading to a quicker temperature drop.

Initially, both water samples started at the same temperature of 27.9°C. Within the first 5 minutes, the temperature of the 400ml sample dropped significantly to 26.0°C, while the 800ml sample's temperature only decreased to 27.1°C. Over time, the temperature of the 400ml sample continued to decrease rapidly, stabilizing at approximately 22.6°C after 50 minutes. In contrast, the 800ml sample's temperature dropped more gradually, reaching around 23.2°C after 70 minutes.

The final equilibrium temperatures observed in the experiment were different for the two volumes. The 400ml sample stabilized at a lower temperature (22.6°C) compared to the 800ml sample (23.2°C). This difference can be attributed to the more efficient heat dissipation in the smaller volume, coupled with the cooling capacity of the TEC-12705, which might be more effective at maintaining lower temperatures with smaller volumes of water.

5. Conclusion

The conclusion of the IoT-based water cooling container project highlights the successful integration of smart technology and user-centric functionality. The precise control of the Peltier element by the ESP32, in conjunction with an adjustable fan, ensures efficient and consistent cooling. The OLED display provides real-time system status, while IoT capabilities allow remote monitoring and control via a smartphone, enhancing user convenience and manageability. This project demonstrates the potential of IoT to transform everyday appliances into intelligent systems that prioritize user safety, energy efficiency, and operational effectiveness, setting a standard for future smart appliance innovations.

6. Future Recommendation

In order to enhance the portability of the prototype, I recommend developing a smaller and lighter version that can be conveniently transported. Additionally, the cooling system's efficiency can be enhanced by upgrading the peltier module with a higher power supply. Lastly, it is important to ensure that not only the water inside the bottle is cooled, but also the entire bottle itself.

Acknowledgement

We gratefully acknowledge the invaluable support to the Faculty of Engineering Technology at University Tun Hussien Onn (UTTM) for their resources and infrastructure, enabling this project's fruition.

References

- [1] B. M. Popkin, K. E. D'Anci, and I. H. Rosenberg, "Water, Hydration and Health," *Nutr Rev*, vol. 68, no. 8, p. 439, 2010, doi: 10.1111/J.1753-4887.2010.00304.X.
- [2] I. Lorenzo, M. Serra-Prat, and J. Carlos Yébenes, "The Role of Water Homeostasis in Muscle Function and Frailty: A Review," *Nutrients*, vol. 11, no. 8, Aug. 2019, doi: 10.3390/NU11081857.
- [3] E. Jéquier and F. Constant, "Water as an essential nutrient: the physiological basis of hydration," *Eur J Clin Nutr*, vol. 64, no. 2, pp. 115–123, 2010, doi: 10.1038/EJCN.2009.111.
- [4] "Dehydration Headache: Dehydration Symptoms & Types of Headaches." Accessed: Jul. 10, 2024. [Online]. Available: <https://my.clevelandclinic.org/health/diseases/21517-dehydration-headache>
- [5] "How Much Water Should You Drink Based on Your Weight? By Ages, 12 Health Benefits." Accessed: Jul. 10, 2024. [Online]. Available: https://www.medicinenet.com/how_much_water_to_drink_based_on_your_weight/article.htm
- [6] "Dehydration: Symptoms & Causes." Accessed: Jul. 10, 2024. [Online]. Available: <https://my.clevelandclinic.org/health/diseases/9013-dehydration>
- [7] "How to Tell If You're Dehydrated: Signs and Symptoms." Accessed: Jul. 10, 2024. [Online]. Available: <https://www.healthline.com/health/how-to-tell-if-youre-dehydrated#signs-in-adults>
- [8] A. Hosseinlou, S. Khamnei, and M. Zamanlu, "The effect of water temperature and voluntary drinking on the post rehydration sweating," *Int J Clin Exp Med*, vol. 6, no. 8, p. 683, Sep. 2013, Accessed: Jul. 10, 2024. [Online]. Available: [/pmc/articles/PMC3762624/](https://pubmed.ncbi.nlm.nih.gov/262624/)
- [9] D. LaFata, A. Carlson-Phillips, S. T. Sims, and E. M. Russell, "The effect of a cold beverage during an exercise session combining both strength and energy systems development training on core temperature and markers of performance," *J Int Soc Sports Nutr*, vol. 9, no. 1, pp. 1–8, Sep. 2012, doi: 10.1186/1550-2783-9-44/TABLES/4.
- [10] "Thermoelectric Cooling Devices (Peltier) | How it works, Application & Advantages." Accessed: Jul. 10, 2024. [Online]. Available: <https://www.electricity-magnetism.org/thermoelectric-cooling-devices-peltier/>
- [11] "Working Principle | PS9888 | Spot Cooling Device." Accessed: Jul. 10, 2024. [Online]. Available: <https://blogs.ntu.edu.sg/ps9888-2020-g09/working-principle/>
- [12] "Advantages of Thermoelectric Cooling - Thermoelectric." Accessed: Jul. 10, 2024. [Online]. Available: <https://thermal.ferrotec.com/technology/thermoelectric-reference-guide/thermalref04/>
- [13] "(PDF) Air Conditioner Using Peltier Module." Accessed: Jul. 10, 2024. [Online]. Available: https://www.researchgate.net/publication/370659755_Air_Conditioner_Using_Peltier_Module
- [14] M. J. Malavika, G. Vijay, C. H. Shiva, and L. Ajay, "COMPRESSOR-LESS REFRIGERATOR BY USING PELTIER DEVICE", doi: 10.56726/IRJMETS41869.
- [15] H. Zhang, X. Feng, and Y. Wang, "Comparison and evaluation of air cooling and water cooling in resource consumption and economic performance," *Energy*, vol. 154, pp. 157–167, Jul. 2018, doi: 10.1016/J.ENERGY.2018.04.095.
- [16] "Advantages of Liquid Cooling - CriticalCxE." Accessed: Jul. 11, 2024. [Online]. Available: <https://criticalcxe.com/advantages-of-liquid-cooling/>
- [17] "Advantages and Disadvantages of Liquid Cooling - Profolus." Accessed: Jul. 11, 2024. [Online]. Available: <https://www.profolus.com/topics/advantages-and-disadvantages-of-liquid-cooling/>
- [18] "What is thermal equilibrium." Accessed: Jul. 11, 2024. [Online]. Available: <https://byjus.com/question-answer/what-is-thermal-equilibrium/>
- [19] "Thermal equilibrium." Accessed: Jul. 11, 2024. [Online]. Available: <http://hyperphysics.phy-astr.gsu.edu/hbase/thermo/thereq.html>
- [20] "Thermal Equilibrium Definition, Equation & Examples - Lesson | Study.com." Accessed: Jul. 11, 2024. [Online]. Available: <https://study.com/learn/lesson/thermal-equilibrium-equation-examples.html>