

Feasibility Study Implementation of Commercial Type Photovoltaic System on Prospective Buildings in UTHM Pagoh

Erin Eriana Eddie Syafzainizam¹, Md Nor Ramdon Baharom^{1*}

¹ Department of Electrical Engineering, Faculty of Engineering Technology, Universiti Tun Hussien Onn Malaysia, 84600 Pagoh, Malaysia

*Corresponding Author: ramdon@uthm.edu.my

DOI: <https://doi.org/10.30880/peat.2024.05.02.017>

Article Info

Received: 27 June 2024

Accepted: 17 July 2024

Available online: 25 November 2024

Keywords

Photovoltaic System, Rooftop, Commercial Type, On-Grid, SOLCAST, ETAP, load estimation.

Abstract

Solar energy, radiation from the Sun capable of producing heat, causing chemical reactions, or generating electricity. Photovoltaic (PV) panels, sometimes referred to as solar panels, are devices that use the photovoltaic effect to turn sunlight into energy. The study is mainly to profile the electrical load and to plan photovoltaic system implementation at Block B. SOLCAST and ETAP were used to do PV system simulation. SOLCAST shows the average irradiance value at UTHM Pagoh specifically at Block B which is the value is high and efficient for electricity to generate. The ETAP software show the simulation of photovoltaic system installation at Block B. It shows that the PV system installation is 100% efficient and effective. The results help decision-makers assess whether a commercial photovoltaic system is feasible and should be installed as a renewable energy source for the Block B of UTHM Pagoh.

1. Introduction

Using renewable energy can help reduce environmental pollution. One of the biggest contributors to human-caused climate change is greenhouse gases like carbon dioxide (CO₂) and carbon monoxide (CO). To combat this, efforts are being made to switch from non-renewable energy sources to renewable ones. In Malaysia, solar energy is a popular choice. Solar panels, mainly made up of crystalline silicon-type solar cells, convert the Sun's energy into usable electricity. These cells are made from layers of silicon and other elements like phosphorus and boron. UTHM Pagoh, like other universities, plans to use commercial photovoltaic (PV) systems in its buildings.

This study will assess the suitability of installing solar PV on Laboratory Block B, focusing on the building structure, especially the roof. Currently, the problem for the study is Block B relies on the grid, which means it uses electricity mainly generated from fossil fuels. This dependence on fossil fuels leads to high and unpredictable operational costs, energy price fluctuations, and potential supply disruptions. Without diversifying its energy sources, UTHM Pagoh will continue to emit high levels of greenhouse gases, undermining its efforts to combat climate change. This will result in a larger carbon footprint and make it hard for UTHM to meet international sustainability standards. Not implementing the PV system also means UTHM will miss the chance to lead by example and gather valuable experience for future projects.

The objectives of this project are to estimate the electrical load and assess the existing electrical network at Block B of UTHM Pagoh, develop a plan to implement the photovoltaic system, and verify the working condition of the proposed photovoltaic system integrated with the existing electrical network at Block B.

The scope and limitations of this study include using solar panels as the main components to absorb solar energy, using inverters to convert DC current from sunlight to AC current for appliances, estimating the load based on fluorescent lights in every laboratory in Block B, focusing the implementation on the rooftop of Block B, and using software like ETAP, SketchUp, and SOLCAST for the project.

2. Literature Review

The study analyzed materials to provide a full and comprehensive assessment of solar system installation technology. They emphasize the many advantages of this newly developed technique, including its efficiency and adaptability. Furthermore, the papers highlight the prospective global applications of photovoltaic system installation, implying that this technology might play an important part in renewable energy solutions globally.

Identification of optimal time for solar energy production, as mentioned by Nur Aini Zulkarnain [1], can help to identify the suitable and best time for optimum energy production and optimizing solar installation to align energy use with sun availability. The implementation of rooftop solar PV system led to significant reductions in greenhouse gases (GHG) emissions across the residential, commercial and industrial sector. Rashmi Roy [2] also stated that the saving in fuel consumption, fuel cost and GHG emission were substantial shows the environmental benefits of transitioning to solar energy. Additionally, Alfatha [3] mentioned that for their study, all simulation is using HeliScope software as a part of comprehensive feasibility study. Surabhi Sharma and Ciji Pearl Kurian [4] mentioned that the performance of the photovoltaic system is influenced by many factors such as geographical location, solar irradiance type of PV module and module orientation. Economic indicators such as Net Present Value (NPV), Internal Rate of Return (IRR), Benefit-Cost (B/C) ratio, payback period, and Levelized Cost of Energy (LCOE) as mentioned by A.Thippongton and K. Suluksna [5], these are important to assess the economic potential of the project. The environmental factors and technical challenges related to the installation of floating solar panels are partially disclosed by these case studies

3. Methodology

The success of a project depends greatly on how well it is executed. This study explains the entire process, including the planning, design, and development of both software and hardware components. This involves the use of inverters, monocrystalline solar panels, wiring, and proper connections.

3.1 System Block Diagram and Research Flowchart

Installing a photovoltaic system requires a few key components. Fig 1 shows a block diagram with the solar panel as the main component, converting sunlight into DC electricity using photovoltaic cells. The panels are mounted on a strong racking structure to ensure they receive optimal sunlight, even in harsh weather. The DC electricity produced by the solar panel is sent to the solar inverter, which converts it into AC electricity. This AC current is then distributed through a distribution panel. The AC current is then distributed through a distribution panel.

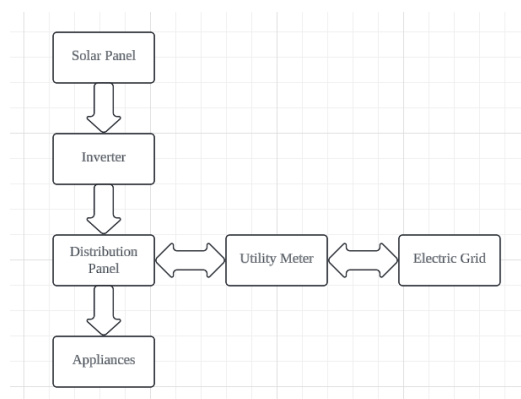

Fig. 1 Solar PV System Block Diagram

Next, based on the Fig 2, the first thing to do for this project is to outline the objectives and scopes of the project. This is the initial phase in the flowchart. The next essential thing to do is to collect data and analysis. It involves an assessment of the site, including roof condition, shading analysis, and energy consumption patterns. After the data have been collected, the next step focuses on exploring different system design options, selecting the appropriate technology, and determining the optimal capacity of the solar PV system. Then, all the data and findings are compiled and summarized for quick reference for decision making. Lastly, the result and conclusion will be documented for feasibility study project, ensuring that valuable insights are recorded for future projects.

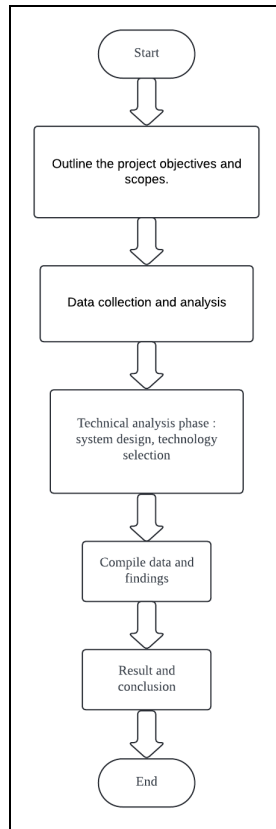

Fig. 2 The flowchart for this project

3.2 Site Assesment

There are several processes or steps that need to be done. The first things are to choose and decide certain area that want to implement the solar. Next, we need to analyze the site and the shading. Rooftop analysis required to visit the site that project area was planned. The Fig 3 shows the area in the Block B building that will be used. The building has been measured to facilitate the process of selecting the size and number of solar panels to be used. This area was chosen because it is a strategic area in terms of the amount of solar radiation and it facilitates the installation process that will be done.



Fig. 3 Site at Block B of UTHM Pagoh



Fig. 4 The area that have been measured

Shading analysis helps determine how shadows from buildings, trees, and other objects affect the sunlight reaching solar panels. This is essential for maximizing their efficiency. By evaluating potential shading issues through site surveys, sun path analysis, and simulation tools, we can find the best spots for placing solar panels to avoid shadows and enhance energy output. This analysis ensures optimal system performance, cost savings, and a longer lifespan for the solar setup, making it a crucial step before installation. Fig 5 shows the shading analysis conducted at Block B. The analysis of the surrounding area and the building concluded that the rooftop of Block B is the most suitable place for solar panels, as it has no shading, while other areas have some shading.

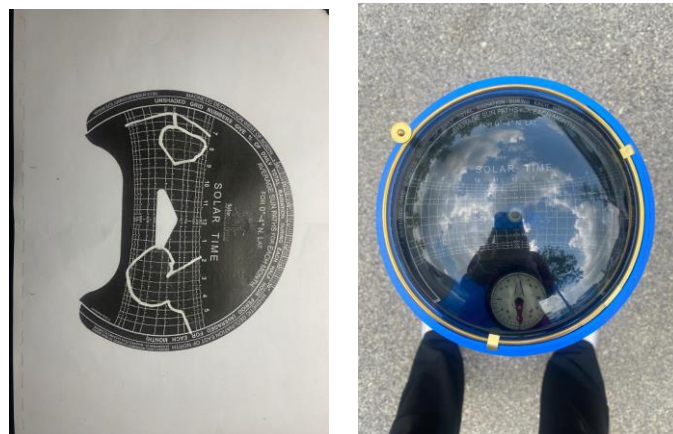

Fig. 5 Shading analysis were conducted

4. Result and Discussion

Data collection includes understanding the theoretical data from computations. Additionally, the data collection is influenced by the high potential site, which affects how well the project system performs.

4.1 3D Layout Design

Fig 6 shows a 3D model of the solar system installation on Block B at UTHM Pagoh. This model illustrates the basic concept and overall appearance of the project, including the position of the solar panels. It shows the optimal angle and height for the panels to maximize sun exposure and avoid shading. The 3D model was created using SketchUp.



Fig 6 Block B with solar PV system

4.2 Solar Irradiance Analysis

Analyzing solar irradiance is crucial to determine the best times for generating the most energy. SOLCAST software was used for this measurement. Fig 7 shows that the highest irradiance on a cloudy day was 349 GHI at UTHM Pagoh. On June 7th, as shown in Fig 8, the highest irradiance values were 784 GHI at 12:00 p.m. and 758 GHI at 3:00 p.m. On June 8th, the highest irradiance was 803 GHI at 12:30 p.m. These data indicate that UTHM Pagoh has high solar irradiance overall, ensuring that the photovoltaic system will generate electricity efficiently.

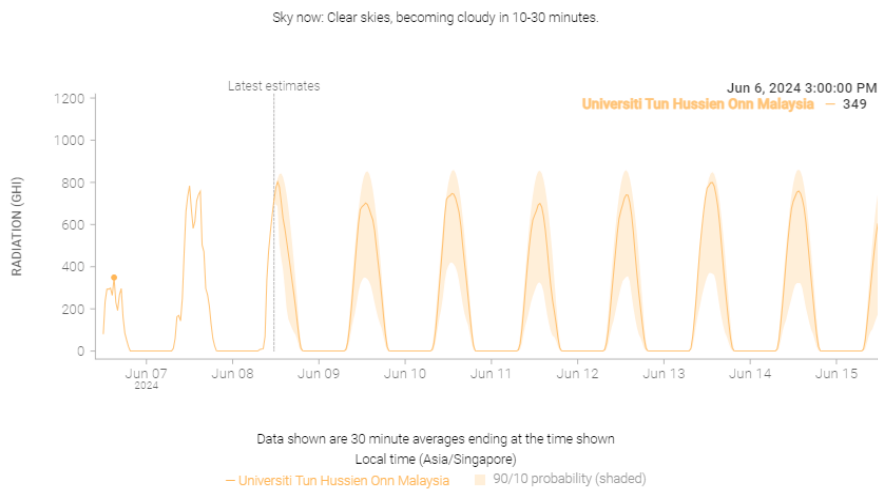

Fig 7 The data for solar irradiance on 6th June 2024

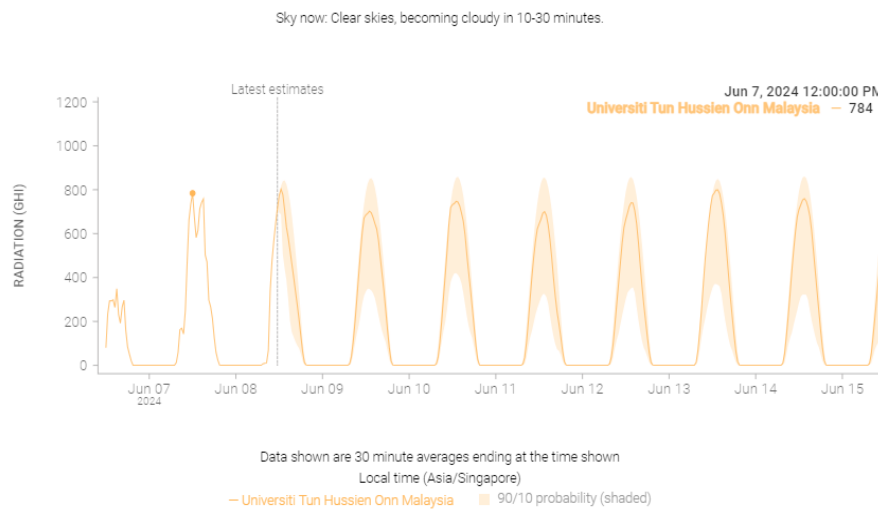

Fig 8 Two highest solar irradiance on 7th June

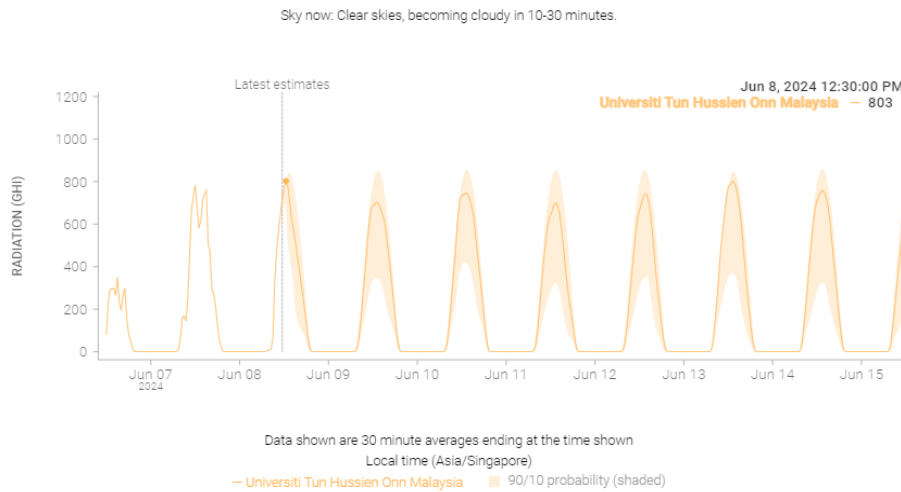

Fig 9 Solar irradiance estimation on 8th June

4.3 Load Estimation

Table 10 shows the calculation for the load estimation (lighting) at Block B of UTHM Pagoh. Firstly, we need to calculate the power consumption demand of Block B. Calculate the total watt-hour of the load/appliances used. Based on the calculation, the estimated total watt-hour of the load is **861.84kWh/day** for the whole Block B. Next, after we calculate the total watt-hour of the load/appliances used, we need to calculate the energy needed from the PV panel. The total watt-hour needs to **multiply with 1.3** for the PV short circuit. The energy that PV panel needs to provide/generate is **1.120392MWh/day**.

Then, after the power consumption demand were calculated, we need to find the sizing and number of the PV panel that want to be use. The total watt-peak of PV panel capacity needs to be calculated. The energy that PV panel need to provide must be **multiply with 3.43** which is panel generation factor. It is depends on the site of the project. To calculate the amount of panel use, the total watt-peak of PV panel capacity needs to be divided with the watt of the panel that we want to use. So, the total panel needs to be installed is **725 modules**.

Lastly, the size of the inverter also needs to be found out. For safety, the inverter should be considered **25-30 %** bigger size. The inverter size should be about **112.039kW or greater**. It is because the values is 30% higher than the total watt of the appliances.

Table 1 Calculation of load estimation

No	Subject	Calculation
1.	Estimation power consumption demands (at Block B). Thirty-eight of (3×28W) fluorescent lights are used 10 hours per day.	Total appliance use =38×(3×28W)×10hours×27 labs =861.84kWh/day (whole Block B) Total PV panels energy needed =861.84k×1.3 (PV array short-circuit) =1.120392MWh/day
2.	Size of the PV panel. 450W PV module.	Total Wp of PV panel capacity needed =1.120392M/3.43 (panel generation factor) =326.644kWp The number of PV panel needed =326.644k/450 =725.87 module (726 modules)

3.	Inverter sizing	<p>Total Watt of all appliances</p> <p>$=38 \times 3 \times 28W \times 27 \text{ lab}$</p> <p>$=86.184kWh$</p> <p>For safety, the inverter should be considered 25-30 % bigger size. The inverter size should be about 112.039kW or greater.</p>
----	-----------------	---

4.4 ETAP Simulation

This project used ETAP software to demonstrate the operational status of the photovoltaic system installed on the rooftop of Block B at UTHM Pagoh. According to Fig 10, the simulation shows photovoltaic system operates at 100% efficiency, producing 905.2 kVA of electricity, which is sufficient to power the lighting load of Block B which required only 862.8 kVA. This results in an excess electricity generation of 42.4 kVA, which is fed back into the grid.

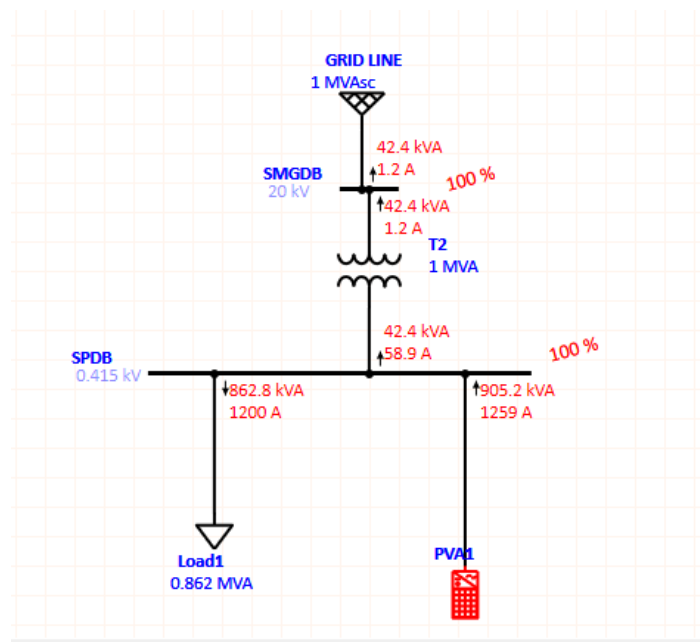

Fig 10 The PV system at Block B simulation's.

5. Conclusion

The outcome of the feasibility study for commercial photovoltaic (PV) system implementation into Block B at UTHM Pagoh is feasible and gives advantages to be realized. According to the study conducted using SOLCAST and ETAP software for simulations, Block B was considered a suitable geography dimension due to high solar irradiance in the area conducive for solar power generation. It was found to run at 100% efficiency, generating more electricity than the unit required for the infrastructure.

A major result of this research is substantial energy savings. The installation of the PV system specifies a saving up almost 100 percent for UTHM Pagoh, as it is expected that generating its own electricity will help in reducing the consumption from grid electricity supply mainly acquired through fossil fuels. Saving money by the boatloads as well as insuring yourself from high energy prices and no supply-lines. It will reduce long-term risk.

Another important benefit highlighted in the study is the positive environmental impact. Implementing the PV system will lead to substantial reductions in greenhouse gas emissions, aligning with global sustainability goals and enhancing UTHM Pagoh's commitment to environmental stewardship. The transition from fossil fuel-based energy to renewable solar power significantly reduces the campus's carbon footprint, promoting cleaner and more sustainable energy practices. This move supports broader efforts to combat climate change and demonstrates leadership in environmental responsibility.

In conclusion, the study recommends a detailed project plan, stakeholder collaboration, and continuous monitoring for successful implementation and optimization of the PV system. These steps are crucial to ensure

that the system operates at its highest efficiency and that any issues are promptly addressed. By adopting renewable energy solutions, UTHM Pagoh not only reaps financial and environmental benefits but also sets a precedent for other educational institutions and organizations to follow. This project underscores the university's leadership in sustainability and innovation, paving the way for a greener future.

Acknowledgement

Communication of this research is made possible through monetary assistance by Universiti Tun Hussein Onn Malaysia and the UTHM Publisher's Office via Publication Fund E15216.

References

- [1] Zulkarnain, Nur Aini. "A Suitability in Assessing PV Potential in UTHM Campus Pagoh Using Homer Simulation." *Progress in Engineering Application and Technology*, vol. 4, no. 2, 21 Dec. 2023, pp. 345–352, publisher.uthm.edu.my/periodicals/index.php/peat/article/view/13078/4479.
- [2] R. Roy, I. J. Fariha, N. Shobnom, P. Mitra and N. K. Das, "Financial Feasibility and Environmental Sustainability of Rooftop Solar PV in Chattogram: A Case Study on Residential, Commercial, and Industrial Buildings," 2024 International Conference on Advances in Computing, Communication, Electrical, and Smart Systems (iCACCESS), Dhaka, Bangladesh, 2024, pp. 01-06, [doi: 10.1109/iCACCESS61735.2024.10499585](https://doi.org/10.1109/iCACCESS61735.2024.10499585).
- [3] Alfatha, A. Obayed, Jawad, Atik, Hossain and M. Mofazzal, "Feasibility Study of a Rooftop Solar System on ULAB Permanent Campus Building," 2023 International Conference on Advances in Electronics, Communication, Computing and Intelligent Information Systems (ICAECIS), Bangalore, India, 2023, pp. 276-281, [doi: 10.1109/ICAECIS58353.2023.10169944](https://doi.org/10.1109/ICAECIS58353.2023.10169944), keywords: {Renewable energy sources;Costs;Buildings;Software;Hardware;Solar system;Telecommunication computing;rooftop solar system;renewable energy integration;sustainable energy;feasibility study;LCOE},
- [4] S. Sharma, C. P. Kurian and L. S. Paragond, "Solar PV System Design Using PVsyst: A Case Study of an Academic Institute," 2018 International Conference on Control, Power, Communication and Computing Technologies (ICCPCT), Kannur, India, 2018, pp. 123-128, [doi: 10.1109/ICCPCT.2018.8574334](https://doi.org/10.1109/ICCPCT.2018.8574334), keywords: {Floors;Software;Production;Inverters;Photovoltaic systems;Azimuth;PV system;PVSYST software;fixed tilt;specific production;specific energy;performance ratio and carbon footprint},
- [5] A. Thippontorn and K. Suluksna, "Feasibility Study of Installing a Rooftop PV Systems in Suranaree University of Technology," 2021 9th International Electrical Engineering Congress (iEECON), Pattaya, Thailand, 2021, pp. 161-164, [doi: 10.1109/iEECON51072.2021.9440369](https://doi.org/10.1109/iEECON51072.2021.9440369), keywords: {Economics;Temperature sensors;Electrical engineering;Sensitivity analysis;Photovoltaic cells;Buildings;Silicon;Feasibility study;Potential;Rooftop PV systems},