

IOT-Enhanced MPPT Charge Controllers for Sustainable Energy

Muhammad Haikal Hashim Abdul Walit¹, Farahiyah Mustafa^{1*}, Lam Hong Yin¹,

¹ Department of Electrical Engineering Technology, Faculty of Engineering Technology, Universiti Tun Hussein Onn Malaysia, 84600 Pagoh, Johor, MALAYSIA

*Corresponding Author: farahiyah@uthm.edu.my

DOI: <https://doi.org/10.30880/peat.2024.05.02.027>

Article Info

Received: 26 June 2024

Accepted: 21 July 2024

Available online: 25 November 2024

Keywords

Solar Energy, Maximum Power Point Tracking (MPPT), Maximum Power Point (MPP), Perturb and Observe (P&O), Incremental Conductivity (IC), Energy Management and Efficiency

Abstract

Solar energy, as a sustainable and eco-friendly source from the sun, faces challenges like intermittent power generation and storage limitations. Integrating batteries resolves the issue of non-storability in standalone PV systems. The Maximum Power Point Tracking (MPPT) technology in solar charge controllers maximize the maximum power point (MPP) maximizes solar panel power output using the Perturb and Observe (P&O) and Incremental Conductivity (IC) method, enhancing efficiency and extending battery life. Components like MPPT, Arduino Nano, LCD display, and Wi-Fi module ensure optimized energy harvesting and battery charging. Overall, utilizing an MPPT solar charge controller with monitoring offers a reliable way to efficiently charge batteries with solar power, showcasing the effectiveness of solar energy in powering and charging systems.

1. Introduction

Solar power represents a ubiquitous form of sustainable energy accessible to all nations, derived from the sun and divided into electricity and heat applications. It stems from sunlight, a consistent eco-friendly resource with global potential to fulfill a year's energy demand in just an hour [1]. The escalating electricity consumption emphasizes the significance of renewable energy, particularly solar power, in providing clean energy solutions. Harnessing solar energy across industrial, commercial, and residential sectors directly from sunlight proves highly efficient and environmentally benign, with minimal environmental impact. The technology encompasses absorbed solar energy systems and photovoltaic (PV) power, efficiently converting solar radiation into electricity.

Solar energy, a valuable and abundant free resource originating from the sun, is harnessed through advanced technologies for electricity generation. These proven methods are widely accepted on a global scale as sustainable alternatives to conventional non-hydro energy sources. Theoretically, solar energy possesses the capability to fulfill worldwide energy demands if efficient capture and distribution technologies were universally accessible [2]. Approximately four million exajoules of solar energy reach the Earth annually, with about 5×10^4 EJ deemed readily exploitable [3]. Despite this vast potential and increasing recognition, the integration of solar power into the global energy mix remains underemphasized [4].

A charge controller, also known as a charge regulator, acts as a voltage or current regulator to prevent batteries from being overcharged. It regulates the voltage and current flow from solar panels to batteries. Typically, most "12 V" panels produce approximately 16 to 20 V, and unregulated charging can cause battery damage due to overcharging. The primary function of a charge controller is to maintain the battery at its optimal

state of charge, protecting it from overcharging and disconnecting the load to prevent deep discharge [5]. The controller directly oversees the battery's condition, adjusting itself based on the battery's state of charge between pulses. This method allows for effective current tapering, resembling a "constant voltage" charging process [6]. Without a charge controller, unregulated charging can lead to excessive battery voltage, resulting in issues like severe gassing, electrolyte depletion, internal heat, and accelerated grid corrosion when the battery is fully charged. Hence, the presence of a charge controller is essential for preserving the battery's well-being and extending its lifespan.

The MPPT charge controller is the most sophisticated type of PV charging controller in existence. It utilizes a synchronous buck converter circuit to reduce the solar panel's higher voltage to match the battery's charging voltage. This controller adapts its input voltage to capture the maximum solar power available and then transforms it into a variable voltage suitable for the battery and load requirements.

The MPPT charge controller functions as a Direct Current to Direct Current (DCDC) converter, enabling the conversion of energy from a higher voltage to a lower voltage without altering the overall power. Crucially, the power remains constant, so if the output voltage is lower than the input voltage, the output current will be higher than the input current. Therefore, to optimize solar panel output, the charge controller must accurately identify the optimal point on the current-voltage curve, known as the Maximum Power Point (MPP). Various strategies have been employed in commercial MPPT charge controllers to pinpoint this crucial point efficiently. The primary goal of any algorithm used in the MPPT charge controller is to swiftly reach the maximum power point while adapting to varying environmental conditions. Typically, more complex algorithms excel at finding the MPP but come with increased computational requirements, research, development time, and potentially higher costs [7]. One straightforward method for tracking the MPP involves utilizing predefined lookup tables with values like temperature and corresponding voltage, reducing computational demands and implementation costs. However, this method may lack the adaptability to changing irradiance levels compared to more advanced solutions, particularly in low-light conditions. Traditional algorithmic approaches to MPPT include the Perturbation and Observation (P&O) method and the Incremental Conductivity (IC) method, both employing "hill-climb" techniques to locate the MPP effectively.

The Perturbation and Observation (P&O) method initiates by adjusting the operating voltage through the duty cycle modification of the DC-DC converter linked to the solar system output. Subsequently, power readings are taken on the load to assess whether altering the duty cycle boosts or diminishes power output. If the adjustments result in power enhancement, further modifications in the same direction are necessary. However, a drawback of the P&O technique is its challenge in precisely pinpointing the Maximum Power Point (MPP). Many P&O controllers exhibit voltage fluctuations around the MPP, leading to wasted power. In scenarios involving partially shaded modules, the MPPT charge controller might struggle to track the local peak compared to the global peak, resulting in suboptimal operation. Misidentifying the correct power point can notably decrease energy efficiency. Conversely, the Incremental Conductivity (IC) method was developed based on observations of the Power and Voltage (P-V) curve characteristics. Introduced in 1993, this approach aimed to address some of the limitations of the P&O method. In environments with substantial irradiation fluctuations, IC strives to enhance tracking efficiency and maximize energy generation.

The generation of power from solar energy faces limitations due to factors such as the inefficiency of solar panels, unpredictable weather patterns, and the characteristics of the load connected to the photovoltaic (PV) system. Employing an MPPT charge controller is vital for optimizing power output. As the MPPT charge controller necessitates a power converter placed between the PV module and the load, the converter's operation significantly impacts the overall performance of the PV system. This research delves into evaluating the effectiveness of MPPT techniques, specifically the Perturbation and Observation (P&O) and Incremental Conductivity (IC) methods, in identifying the Maximum Power Point (MPP). It is crucial to carefully design the MPPT charge controller to ensure the PV system operates at peak power levels, enhancing power transfer from solar panels to batteries and maximizing the efficiency of battery charging [8].

2. Literature Review

2.1 Solar Energy

Solar energy is an excellent alternative as it is a clean and sustainable energy source abundant in most regions. In just 90 minutes, the sun provides enough power to meet the Earth's energy needs for one year. Despite this vast potential, the energy harnessed from solar sources currently represents only a small fraction of the world's current energy mix. Nevertheless, this is swiftly changing, driven by global efforts to enhance energy access, ensure supply security, and address climate change. [12]. Solar energy, which comes from the sun, is one of the most plentiful sources of free energy on our world. Solar energy has the potential to meet the world's energy needs. The yearly quantity of solar energy hitting the Earth is believed to be around four million exajoules (1EJ = 10¹⁸J), with roughly 5x10⁴ EJ deemed readily available. Despite its enormous potential and growing reputation,

solar energy's contribution to global energy supply is still small [9]. In theory, the quantity of solar energy that reaches the Earth is nearly 4200 times that which is anticipated to be utilized by the world population in 2035. The planet has the capacity to receive enough solar energy in a few hours to cover its whole annual energy requirements [10]. The quantity of solar energy that can be harnessed varies based on the location, as illustrated by the annual average solar irradiation distribution across the Earth's surface in Figure 1.

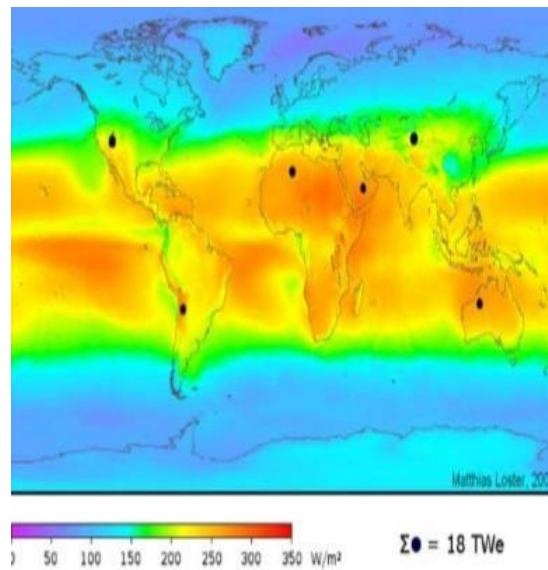

Fig. 1 Annual Average Solar Irradiation Distribution Across the Earth's Surface [13]

2.2 Solar Photovoltaic (PV) System

Solar PV and storage systems are categorized into three types: grid-tied PV system, off-grid PV system, and hybrid PV system. A grid-tied PV system is a basic solar system equipped with a standard grid-tied inverter, and it does not include a battery bank for storage. Energy from a grid-tied system can only be generated and utilized during daylight hours. This system is highly cost-effective, simple to install, maintain, and entails minimal upkeep [11]. In an off-grid solar PV system, a battery is employed to store the generated power during the day for later use, including in emergency situations and during the night. This system is advantageous as it supplies sufficient energy for a home and can power locations that are not connected to the grid. Off-grid systems involve additional components and are therefore more costly than grid-tied systems [12]. The grid-tied PV system and the off-tied PV system is illustrated in Figure 2.

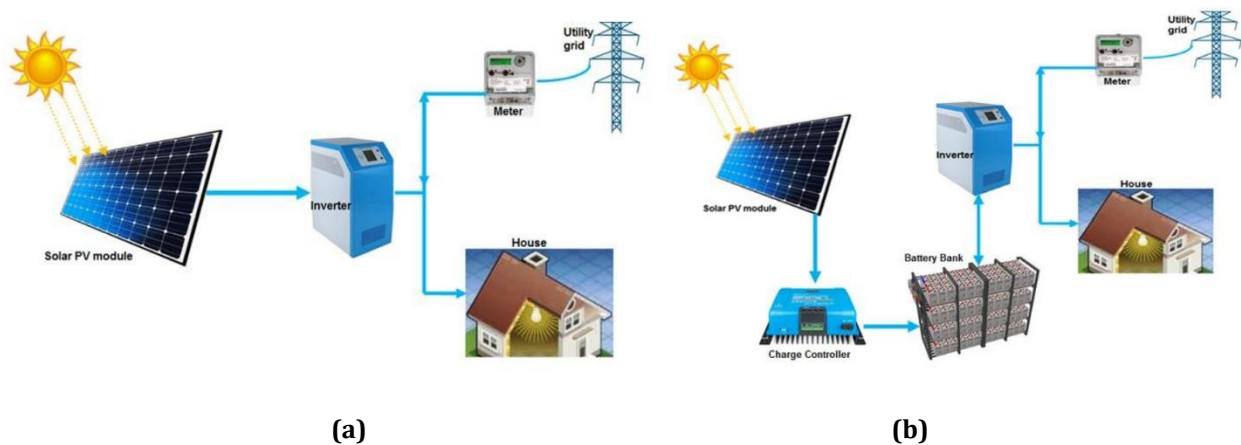

Fig. 2 (a) Grid-tied PV system ;(b) Off-tied PV system

2.3 Solar Charge Controller

The most commonly utilized modern charge controllers in the off-grid solar industry are the pulse width modulation (PWM) and maximum power point (MPPT) controllers. Both methods are excellent choices for effectively charging the battery. The primary role of the MPPT charge controller is to extract the maximum power from the PV module. It achieves this by analyzing the PV module output, comparing it to the battery voltage, and determining the optimal power that the PV module can provide to charge the battery, resulting in the highest current into the battery. Additionally, it functions as a DC-to-DC converter, taking a DC input from the PV module, converting it to AC, and then transforming it back to a DC voltage and current with varying values to match the PV module to the battery [13]. When the battery bank reaches full capacity, the PWM controller becomes operational. It is employed to regulate high current and voltage levels [13].

3. Methodology

3.1 Project Block Diagram

The system is divided into four sections which is the input, microcontroller as the brain, the output, and the IoT platform as shown in the Figure 3. The Arduino Nano was chosen to be the microcontroller for this project because of the compact size and flexible microcontroller board. The Arduino Nano is stated as a brain of the project because it is the system central processing unit, responsible for performing and analyzing all data from the input and transmitting the required signal to its controlling outputs, which are the LCD display and the ThingSpeak web.

The solar panel is the input device of this project. There are two parameter that is measured by the voltage sensor and current sensor which is the current and voltage supply from the solar panel. While the buck converter is used to regulated the voltage supplied to the battery during charging. Except ESP8266 module all the others component can be run by 5 V power supply. The ESP8266 module need powered less than 3.7 V. The Arduino Nano received all the signal that transmitted from the sensors then send it to the output LCD display to display the voltage, current, power usage, and the status of the charging battery. Furthermore, the ESP 8266 will use a Wi-Fi connection to transmit data to the ThingSpeak, which serves as the system IoT platform.

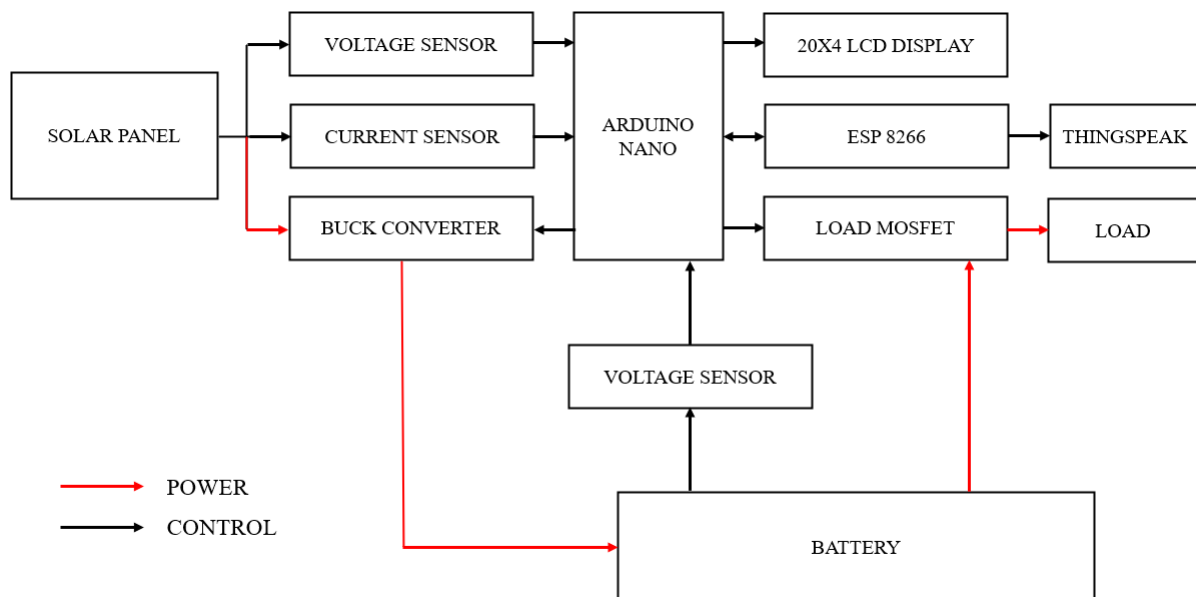

Fig. 3 Block Diagram of Project

3.2 Project Flowchart

Figure 4 show the flowchart of the project. When the sun rays to the solar panel, the solar panel will extract the solar energy from the sun. Unfortunately, the solar panel cannot extract the solar energy efficiently. That is why the MPPT solar charge controller is used to maximizes the power output of the solar panel. The MPPT is activated before the charge control system. During charge, the feedback circuit gives real-time battery voltage and current data to determine the current battery charging state. The I_a is the charge current for constant voltage (CV) charging, while I_b and I_c are the charge and discharge currents for Reflex charging. CV charging is applied when the battery side current $I > I_a$. While the reflex charging is used when the battery side current $I_b > I > I_c$. Finally, whether the battery is full determined by the state of charge (SOC) if the $SOC > SOC_a$.

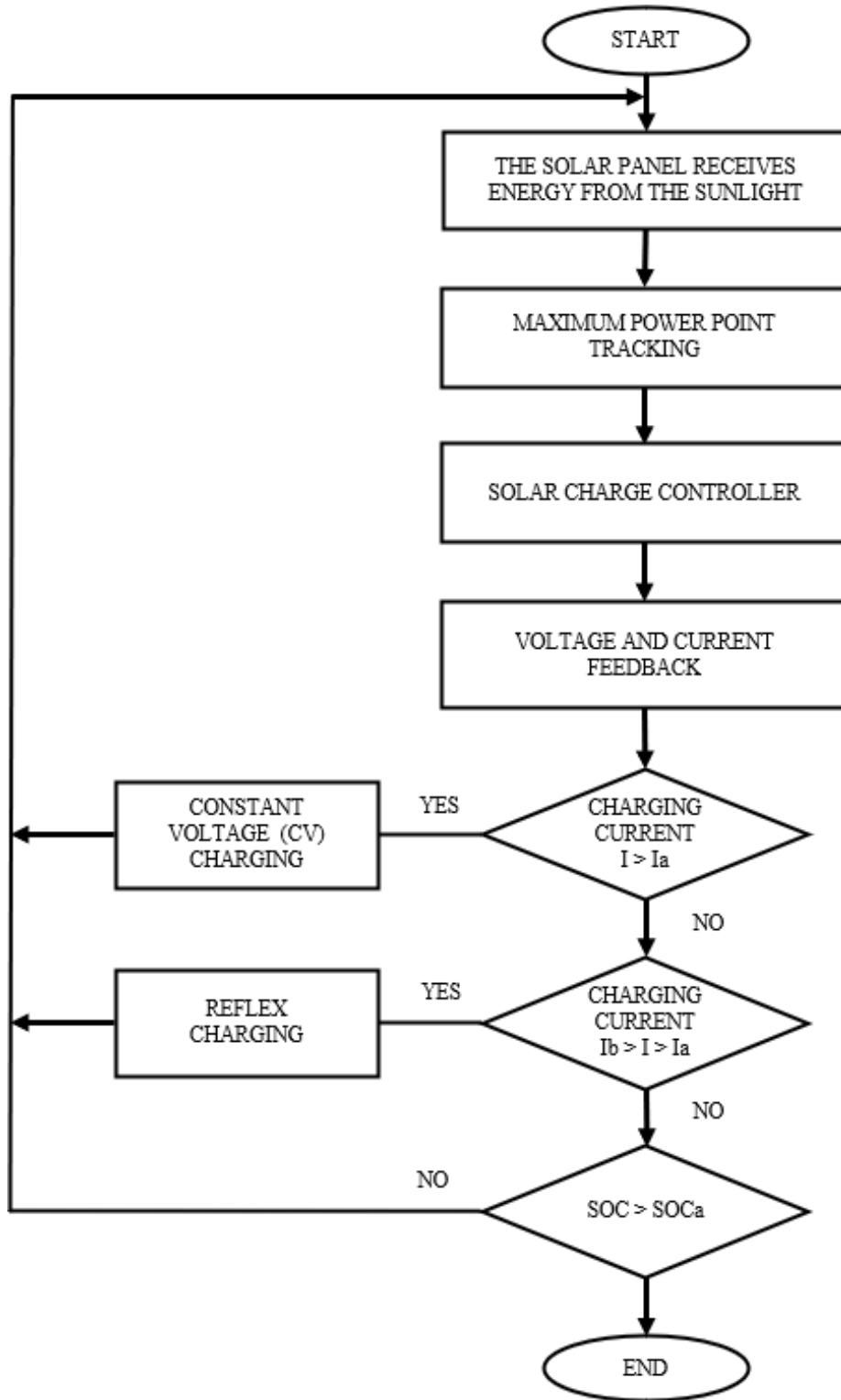

Fig. 4 Flowchart of the Project

3.3 Schematic Diagram

Figure 5 show, the prototype design of the project includes a solar panel, 12 V lead- acid battery and monitoring system. There is sensor that used to measure the voltage and current to control the battery charging and the buck converter to step up and regulate the voltage. All the parameter is show in LCD. This project makes great

use of the ThingSpeak system, which contains a variety of capabilities that enable developers to get information about battery analysis. One of the features allows users to review data from the voltage sensor, which is then used for data visualization.

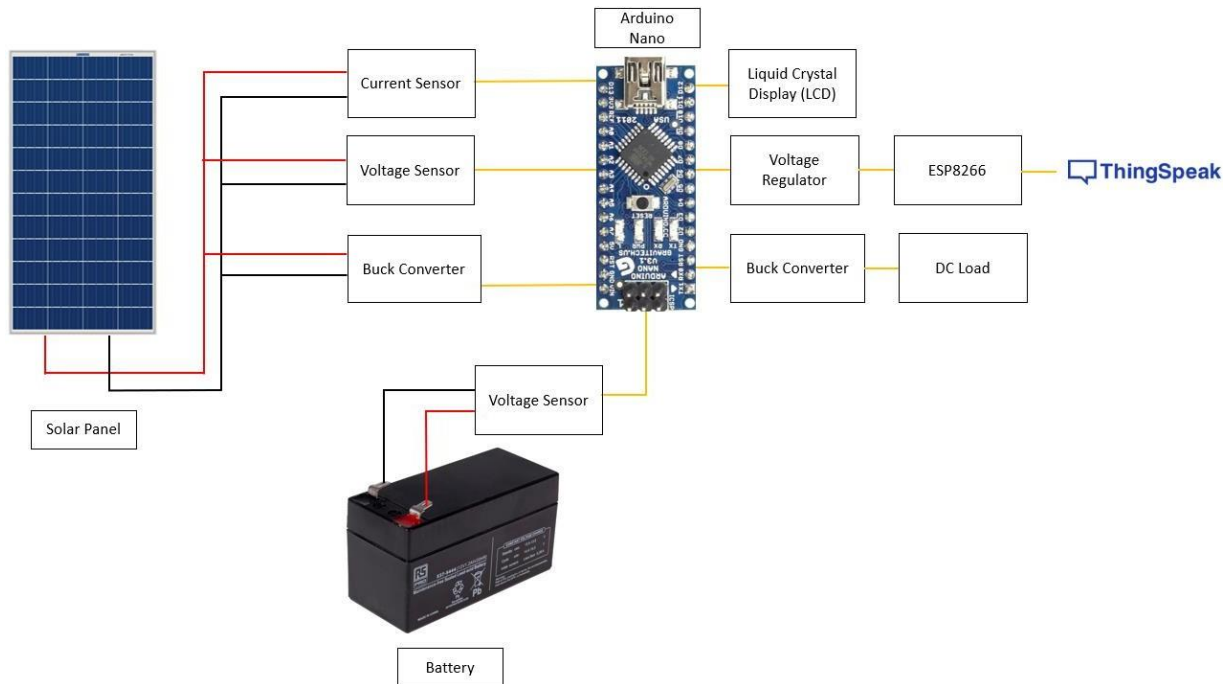

Fig. 5 Schematic Diagram

3.4 Prototype Setup

The prototype setup of the project is depicted in Figure 6. The solar panel generate the electricity to charge the lead- acid battery and supply to the load. The current and voltage generated by the solar panel can be monitored using a current sensor and voltage sensor for recording purposes. The buck converter is use to step down the voltage from the solar panel to achieve the maximum voltage for Arduino Nano. The voltage sensor at the battery is to evaluate the charging condition whether it is charged at maximum voltage, normal voltage or low voltage. The maximum load voltage can go up to 12 V. The voltage regulator is used to regulate the voltage for ESP8266 that has 3.3 V operation. Once a Wi-Fi connection has been established, the value of battery voltage will be displayed in the ThingSpeak platform.

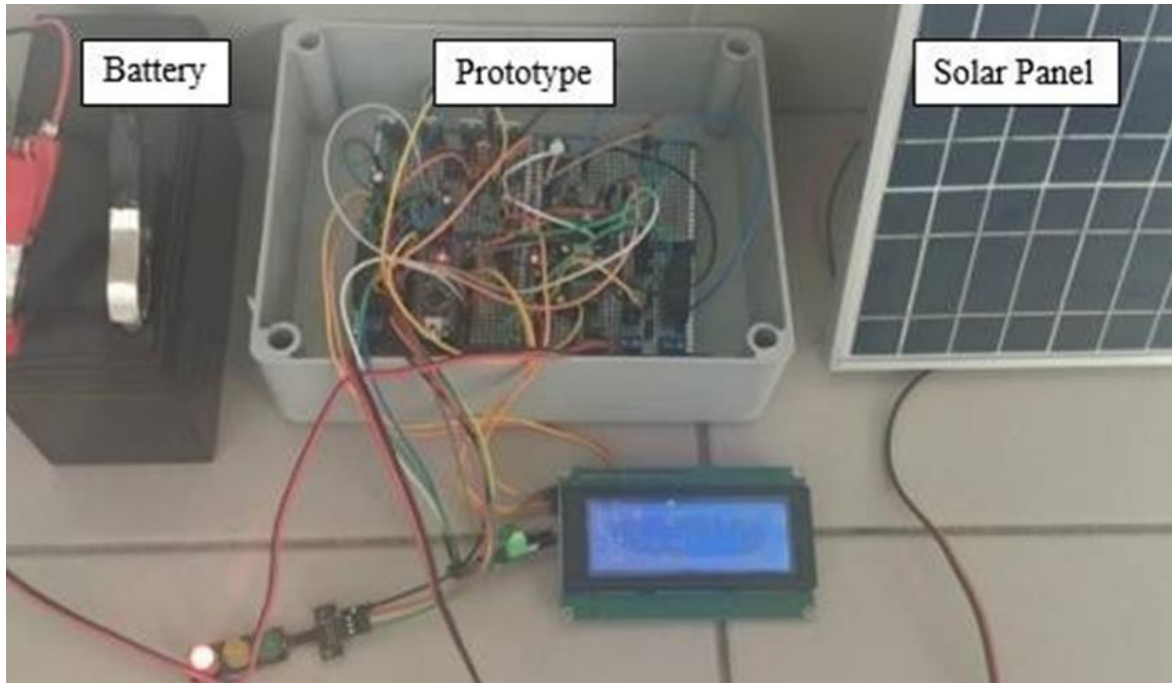

Fig. 6 Prototype Setup

3.5 IoT Setup

ThingSpeak is an open IoT platform with MATLAB analytics that enables users to collect, store, analyze, and visualize data from various sources such as sensors and devices in real-time. It provides tools for data collection, storage, visualization, and analysis, allowing users to monitor trends, patterns, and insights derived from their data streams. ThingSpeak is commonly used in IoT applications like environmental monitoring, home automation, and industrial automation, offering flexibility and easy integration with other IoT devices and software interfaces. Figure 7 show the interface setup of the ThingSpeak platform.

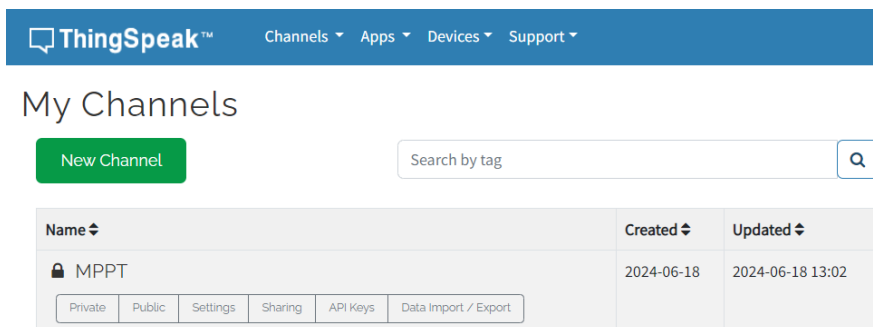

Fig. 7 IoT Setup

4. Result and Discussion

4.1 Voltage Sensor Circuit

The voltage sensor is a device for measuring voltage. Voltage sensors measure voltage in a variety of ways, including high voltages and low current levels. These devices are required for a variety of applications, including industrial controls and power systems. The Arduino analog inputs can measure DC voltage between 0 to 5 V, and this range may be extended by connecting the voltage sensor to form a voltage divider. The voltage divider reduces the voltage detected within the range of the Arduino analogue inputs. The voltage sensor is used for solar panel and battery to measure their output voltage. Figure 8 show the output voltage measurement from the voltage sensor and multimeter, respectfully.

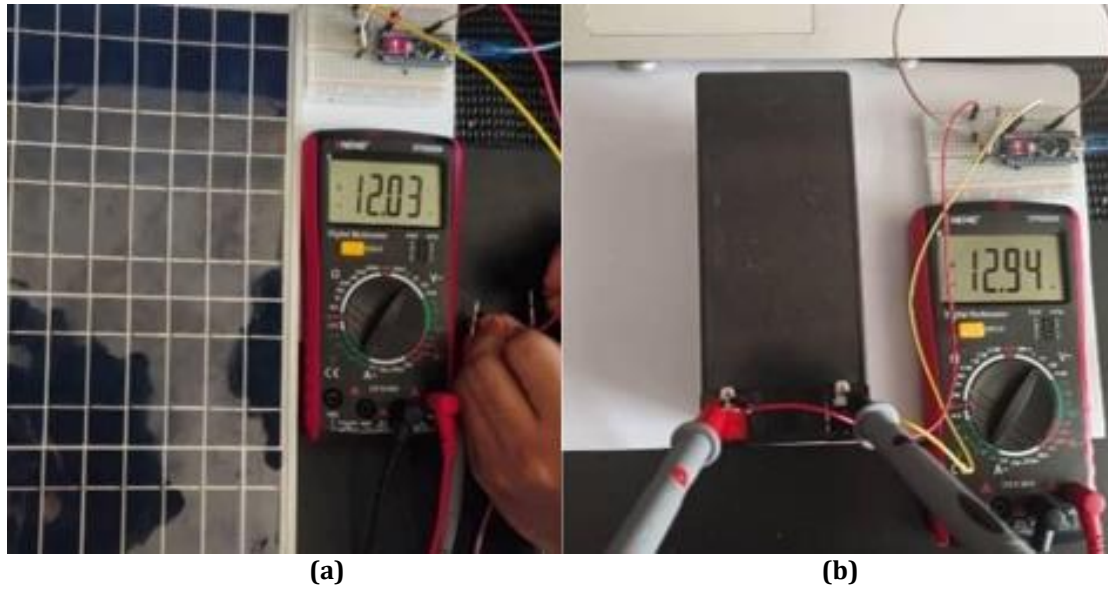

Fig. 8 (a) Voltage Sensor Testing Circuit Connected to the Solar; (b) Voltage Sensor Testing Circuit Connected to the Battery

4.2 LCD Circuit

The LCD show the certain parameter that are important during the battery charging. The purpose of the LCD is to display all the value that measure from the sensor such as voltage, current, power, battery percentage, and the load depicted in Figure 9.

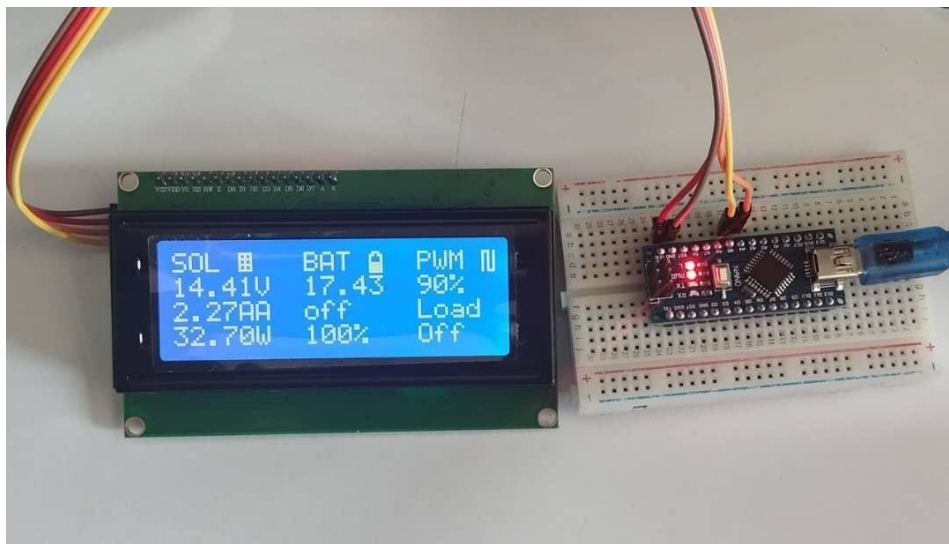

Fig. 9 LCD testing circuit

4.3 Prototype Result

In the conducted project focused on charging a lead-acid battery using solar power and monitoring the data on the ThingSpeak platform, an experimental setup was established. The project involved gathering data from a voltage sensor installed on both the solar panel and the battery, with the results detailed in Table 1. Notably, during the charging process, an LED indicator was utilized to display the battery status visually: red light denoting low voltage, green light indicating a fully charged state, and yellow light representing a status between nominal and full charge. Furthermore, the battery voltage readings were meticulously logged and tracked on the ThingSpeak platform, as visualized in Figure 10, enabling comprehensive monitoring and analysis of the charging process.

Table 1 Voltage Measurement from Solar Panel and Battery

No	Time (24H)	Solar Panel Voltage (V)	Battery Voltage (V)
1	1000 a.m.	20.06	12.30
2	1100 a.m.	19.70	12.37
3	1200 p.m.	21.53	12.52
4	1300 p.m.	22.17	12.67
5	1400 p.m.	20.97	12.73
6	1500 p.m.	20.71	12.78
7	1600 p.m.	19.43	12.82
8	1700 p.m.	19.27	12.85

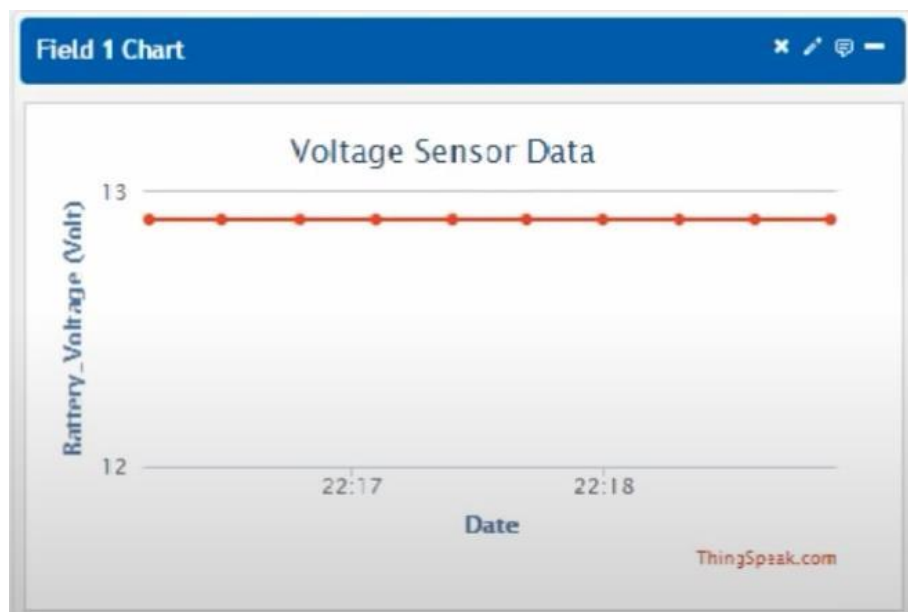
**Fig. 10** Battery Voltage Measurement in ThingSpeak platform

5. Conclusion

The project aims to develop IoT-enhanced MPPT charge controllers for sustainable energy use in residential and commercial electrical systems. The focus is on designing a 10 W to 150 W MPPT charge controller with a monitoring system to track the charging battery status efficiently. The MPPT algorithm developed is optimized for varying irradiance levels, and the PV module output characteristics concerning temperature variations are analyzed. The research explores the P&O and IC algorithms' concepts and features. Utilizing current and voltage sensors, the system can measure solar panel parameters like voltage, current, and power output. Integration of a Wi-Fi module enables remote monitoring through LCD displays and the ThingSpeak web app, enhancing system efficiency and preventing battery damage. The project's success hinges on achieving all outlined objectives and constructing a functional prototype.

Acknowledgement

The authors express their gratitude to the Faculty of Engineering Technology at Universiti Tun Hussein Onn Malaysia for its assistance.

References

- [1] Verma, K. Electricity Generation from Solar Energy. <https://journal.ijprse.com/index.php/ijprse/article/view/65> (2020, June 16).
- [2] Blaschke T, Biberacher M, Gadocha S, Schardinger I. Energy landscapes: meeting energy demands and human aspirations. *Biomass- Bioenergy* 2013; 55:3–16.
- [3] World Energy Outlook, International Energy Agency. <http://www.worldenergyoutlook.org/weo2012/>. 2012
- [4] Energy Technology Perspectives 2012 – Analysis - IEA. IEA. <https://www.iea.org/reports/energy-technology-perspectives-2012> (2012, June 1).
- [5] Gates, A. (n.d.). Solar Charge Controller Basics. NAZ Solar Electric. <https://www.solar-electric.com/learning-center/batteries-and-charging/solar-charge-controller-basics.html/>
- [6] Oti Stephen Ejiofor, Nnadi Damian Benneth, Ogbuefi Uche, Ugwu Celestine. Design and Development of a Charge Controller for a Photovoltaic System. *International Journal of Innovative Research in Electronics and Communication*. <https://doi.org/10.20431/2349-4050.0603001> (2019, January 1).
- [7] What are the benefits and drawbacks of using MPPT charge controllers for off- grid solar system www.linkedin.com. <https://www.linkedin.com/advice/0/what-benefits-drawbacks-using-mppt-charge-controllers#:~:text=MPPT%20charge%20controllers%20use%20a,off%20at%20a%20high%20frequency.> (2023, December 16).
- [8] Alik, R., & Jusoh, A. An enhanced P&O checking algorithm MPPT for high tracking efficiency of partially shaded PV module. *Solar Energy*. <https://doi.org/10.1016/j.solener.2017.12.050>. (2018, March 1).
- [9] E. Kabir, P. Kumar, S. Kumar, A. A. Adelodun, and K.-H. Kim, "Solar energy: Potential and future prospects," *Renewable and Sustainable Energy Reviews*, vol. 82, pp. 894-900, 2018
- [10] H. Weldekidan, V. Strezov, and G. Town, "Review of solar energy for biofuel extraction," *Renewable and Sustainable Energy Reviews*, vol. 88, pp. 184-192, 2018.
- [11] Solarpowerworldonline. What are some common types of solar PV and storage installations. <https://www.solarpowerworldonline.com/2015/10/what-are-some-common-types-of-solar-pv-and-storage-installations/>. 2015.
- [12] Ghenai, Chaouki, Merabet, Adel, Salameh, Tareq, Pigem, Erolacolon. Grid- tied and stand-alone hybrid solar power system for desalination. *Desalination* 435, 172–180. <http://dx.doi.org/10.1016/j.desal.2017.10.044>. 2018
- [13] A. Pradhan, S. M. Ali, S. P. Mishra and S. Mishra, "Design of Solar Charge controller by the use of MPPT Tracking System", *International Journal of Advance Research in Electrical, Electronics and Instrumentation Engineering*, Vol. 1, Issue No. 4, 2012, pp. 256-261.
- [14] B. Swarnakar and A. Datta, "Design and Implementation of PWM charge controller and Solar Tracking system", *International Journal of Science and Research (IJSR)*, Vol. 5, Issue No. 5, May 2016, pp. 1214 – 1217. Retrieved from <https://www.ijsr.net/archive/v5i5/v5i5.php>