

## Smart Anti Trip Distribution Board

Jans Yerikho Justin<sup>1</sup>, Maizul Ishak<sup>1\*</sup>

<sup>1</sup>Faculty of Electrical Engineering Technology,  
Universiti Tun Hussien Onn Malaysia, 84600, Pagoh, Johor, MALAYSIA.

\*Corresponding Author Designation

DOI: <https://doi.org/10.30880/peat.2023.04.01.035>

Received 15 January 2023; Accepted 12 February 2023; Available online 12 February 2023

**Abstract:** When electrical problems occur, which would result in a loss in the supply of electricity to residential buildings, power outages are a typical concern. Power continuity is crucial for household users since some items like their refrigerators, aquariums, and alarm systems need a constant supply of electricity. The earth leakage circuit breaker (ELCB) will trip if a fault occurs in the system, cutting off power to all the equipment. Therefore, the proposed project is to design an automated system for the ELCB to reset. This project addresses the need for constant standby close to the DB to switch on after a trip and the capacity to monitor the power output. In this project, the Arduino Uno microcontroller is used in this project to operate the servo motor and GSM module, and the ESP8266 is connected to the Internet of Things to get real-time data from the distribution board. The Global System for Mobile (GSM) will send message to user after three times reset count to the ELCB. Furthermore, the servo motor mechanical design can be improved in a way to pull the ELCB switch more efficient.

**Keywords:** Arduino, ESP8266, GSM Module, Servo Motor, ELCB,

### 1. Introduction

The electrical and electronic appliances that depend on a constant supply of electricity are impacted when tripping happens when no one is home. The refrigerator is one example. Typically, food is kept in the refrigerator to preserve its freshness for a longer time. However, the refrigerator cannot keep the food from going bad without power. For instance, if milk is kept in a refrigerator without power for an extended period of time, it would ultimately deteriorate and become unusable. Additionally, if the security system is unable to work correctly due to the temporary fault, then the security system is not functioning. In the worst-case scenario, power interruptions might cause damage to home equipment or disrupt the residential system. Power outages to loads, such as lightning, may be disastrous, resulting in property damage and human lives. Constant power supply is crucial in delivering the required electricity.

ELCBs are one of the protective devices that must be installed on all household wiring in order to safeguard users and equipment. Referring to Suruhanjaya Tenaga 2008 regulation 36(3) PPE 1994, it was specified that the installation equipment or electrical devices that consumers contact with their

---

\*Corresponding author: [maizul@uthm.edu.my](mailto:maizul@uthm.edu.my)

2023 UTHM Publisher. All rights reserved.

[publisher.uthm.edu.my/periodicals/index.php/peat](http://publisher.uthm.edu.my/periodicals/index.php/peat)

hands must be protected from earth leakage and must employ ELCBs with a rating of less than 30 miliampere [1]. Typically, home security features an ELCB that is mounted on the distribution box (DB). Earth Leakage Circuit Breaker is one type of electrical equipment that used as a protection device [2]. Its primary function is to turn off the power when a fault occurs. The ELCB uses mechanical switch that need to be activated manually, After the ELCB is being tripped, it will remain OFF until the user pushes it back ON [3]. Hence, the biggest issue arises if the ELCB has a fault and no one is available to turn it back on for a variety of reasons [4].

### 1.1 Objectives

The objectives of this project:

- i. To develop Smart Anti Trip Distribution Box using Arduino Uno with user real time monitoring for single phase system.
- ii. To design a way for automatically turn back ON if the ELCB trips caused by surge current from lightning.
- iii. To analyse output of distribution box by real time monitoring using ESP8266 for IoT usage.

### 1.2 Scope of Project

- i. The overall system is powered using 5V AC adapter powered from Uninterruptible Power Supply (UPS).
- ii. This project's voltage range will be confined to 240V and ELCB.
- iii. This project use AC voltage sensor module ZMPT101B which limited to single phase system and PZEM-004T module to monitor the output.
- iv. This system needs high torque servo MG996R to pull the ELCB.
- v. The project only conducted in residential single phase.

## 2. Literature Review

Based on the findings from a few previous projects in past years, the development of project that are similar to Smart Trip Switch for Distribution Box has become so advanced, some of the technology has can detect the type of fault condition which is useful information for the user. The objectives of this project cannot be fulfilled with all these previous projects, but this project is invented to adapt the knowledge that has been learned throughout the course especially in programming and electronics wiring besides giving out cheaper alternatives to someone.

Based on the related project, it is safe to conclude that there have been many improvement and new features that has been added. One common feature that similar throughout all of these projects is the ability to turn ON the ELCB. But each of these projects have different types of approach to turn ON the ELCB. For example, the use of relays [3][4], triode [5], and DC motor [6]. Therefore, this project will a servo motor and as a different approach without modifying the original ELCB and have a separate box that will contain all the electronic components. The reason is to ease the user installation without doing some heavy modifications to the distribution board and the ELCB. Next, the sensors that used in most of the projects detects current from the main supply for detection and measurement of the fault. For example, current transformer and hall sensor.

The development of this system necessitates a suitable microcontroller, servo motor, and power supply circuit. Microcontrollers are susceptible to damage from both overvoltage and undervoltage. The power supply should have 5V to work properly and 3A current since a high torque servo motor requires a high current to operate. This prevents damage to the circuit from occurring. The device that is in the

same circuit as the motor may experience a voltage drop or shortened an electronic component life span if the power supply is not stable [6]. Other than that, these projects use Switch Mode Power Supply (SMPS) and transformer to step down the main supply 240V to the suitable operating voltage (5V). But this project will only use power supply from the Uninterruptible Power Supply (UPS) and use a 5V AC adapter to power the system.

Lastly, Iot and GSM module can be implemented to this project for user notification and real time monitoring. Based on past projects, web server [5] mostly used and Blynk application shall be used in this project as Blynk platform is easier to configure and operate rather than web server. Arduino Uno will be used as for the system control and ESP 8266 will be used for real time monitoring. The benefit of these is the program can be executed using Arduino IDE program which use knowledge on C/ C++.

### 3. Methodology

The design process and circuit diagram of the Smart Anti Trip Distribution Board will be discussed below. Based on the study on literature review related to the project that has been done, the Smart Anti Trip Distribution Board can be produced by understanding the previous projects and combined the knowledge to produce a better result from the previous projects.

#### 2.1 System Block Diagram

Block diagram is used to visualize the operation of the whole system of Smart Anti Trip Distribution Board. The block diagram is separated into two which block diagrams for Arduino Uno and block diagram for ESP8266. Figure 1 shows the Arduino Uno block diagram.

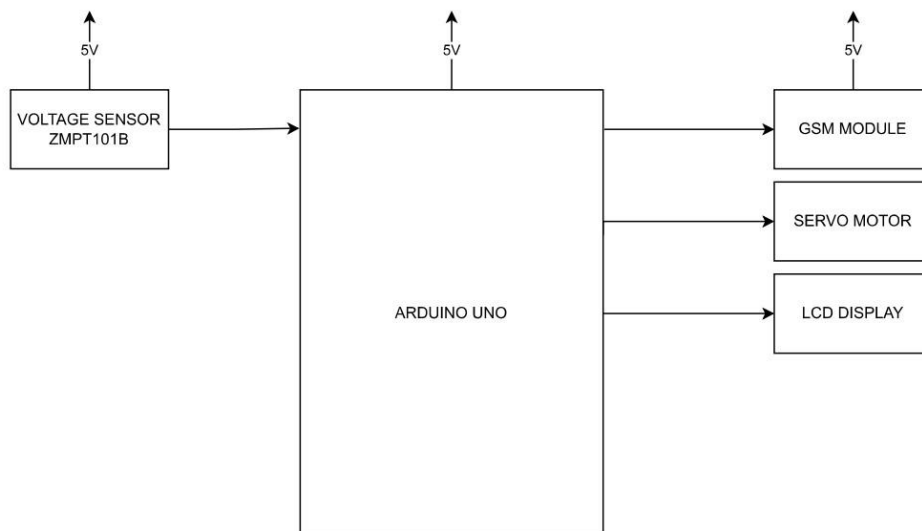

**Figure 1: Arduino Uno Block Diagram**

Figure 1 consists of Voltage Sensor ZMPT101B as inputs connected to the Arduino Uno with a 5V power supply. When voltage sensor sends a signal to Arduino, it will process the data to activate the output such as GSM Module, Servo Motor and LCD Display. When the voltage sensor detects voltage lower than 50V, then the servo motor will be triggered to pull the ELCB switch. The Servo motor will

automatically flip back on the ELCB within 3 seconds. If the ELCB trip again, the servo will automatically pull the ELCB switch again with 3 seconds interval. The process will stop after the voltage sensor detects voltage is more than 50V. Finally, the LCD Display is to show the operation of the system such as “ELCB ON” or “ELCB Tripped”. Figure 2 shows the block diagram of ESP 8266.

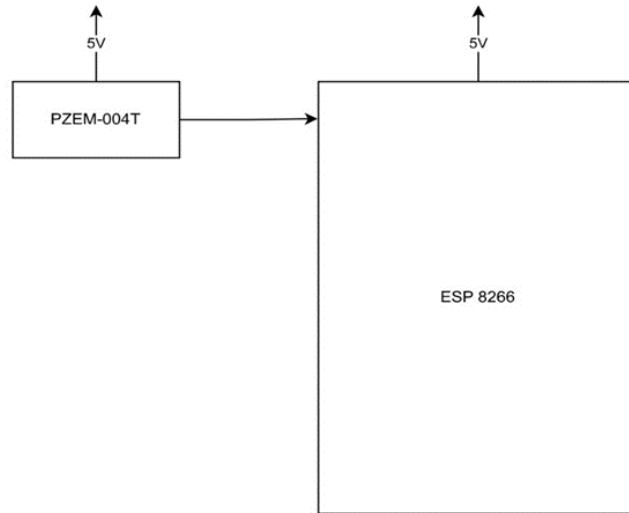
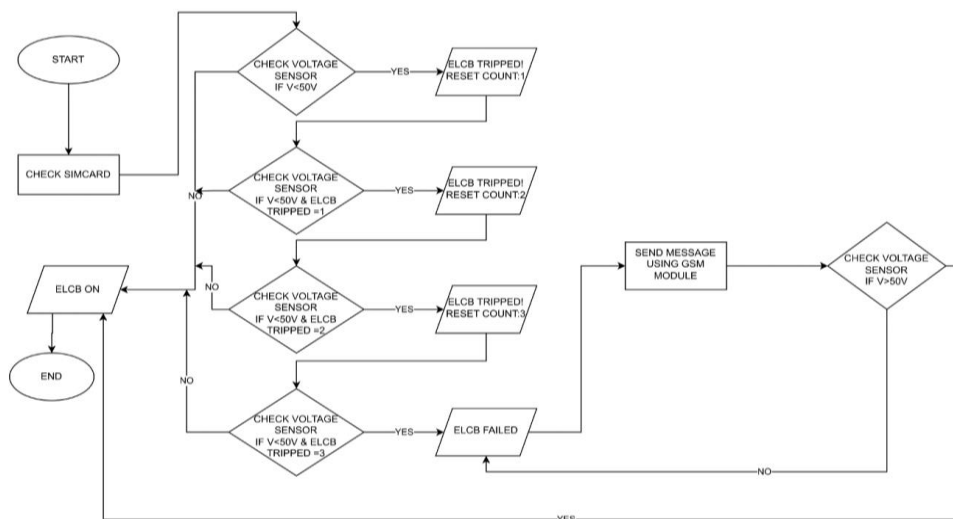

**Figure 2: ESP 8266 Block Diagram**

The ESP 8266 block diagram consist of PZEM-004T as an input to send data to the ESP8266 and the ESP8266 will output the data through Blynk application.

**2.2 Flow Chart of Smart Trip Switch Distribution Board**

A flowchart is a diagram that shows a process' individual phases in their proper order. Figure 3 shows the overall system for Smart Anti Trip Distribution Board.



**Figure 3: Flowchart of Smart Anti Trip Distribution Board**

For the first operation, the Arduino Uno reads the simcard in GSM module to connect to the network. The system then checks the voltage sensor to detect the ELCB condition. The tripping value is set to 50V for the voltage sensor to detect trip. When voltage sensor detects trip, the servo motor will

be triggered to pull the ELCB switch. The system only attempt reset count for 3 times to prevent any damage to the appliance. After that, LCD will display ELCB failed and GSM module will send message to the user.

### 2.3 Circuit Diagram

The circuit is a guide for the wiring of the electronic components. Figure 4 shows the Arduino Uno circuit diagram. The Smart Anti Trip Distribution Board consist of two circuit diagram, where Arduino Uno used for auto reclosure system while ESP 8266 used for real time monitoring.

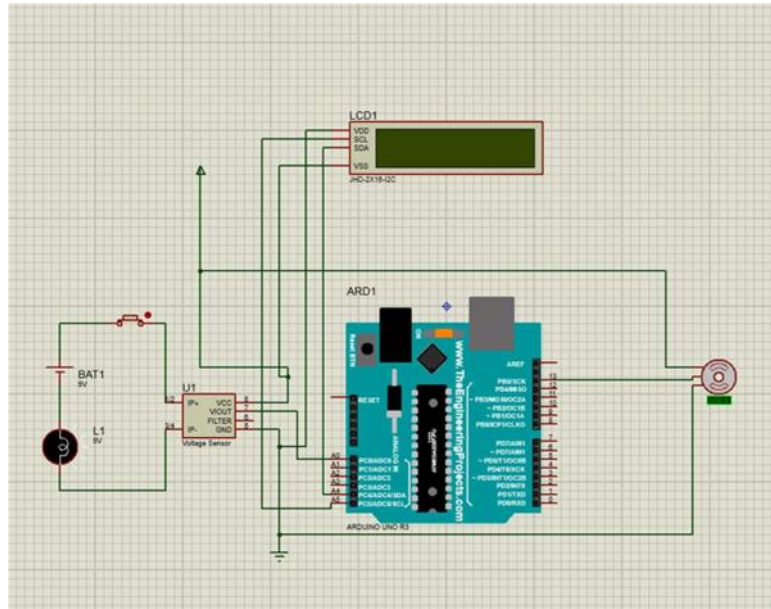

**Figure 4: Arduino Uno Circuit Diagram**

The circuit diagram consists of Arduino Uno as the main component to control this system. The servo motor acts as ELCB ON trigger connected to the pin 13. Next, the voltage sensor is connected to the pin A0 and the lamp acts as a load to indicate that voltage is flowing through the circuit. After that, the LCD connected to pin SDA and SCL to display the condition of the ELCB. Figure 5 shows the ESP8266 circuit diagram. The Arduino Uno circuit functions as the system for the automatic reclosure of the ELCB mechanical switch.

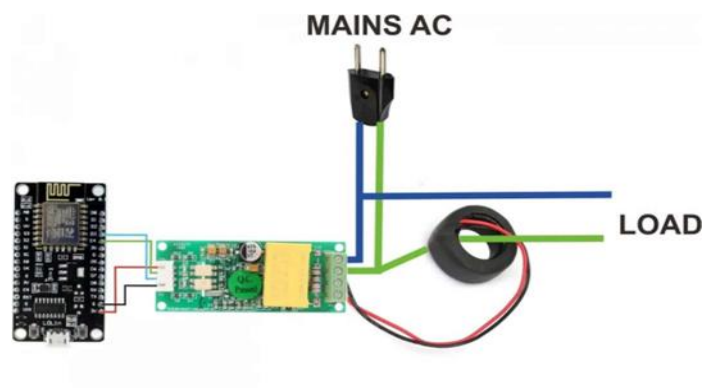

**Figure 5: ESP8266 Circuit Diagram**

The ESP 8266 main function in this system is only to monitor the power output using Blynk App. The RX and TX connection is on pin D4 and D3 respectively. The ESP 8266 only works for real time monitoring of the Smart Anti Trip Distribution Board.

#### 4. Results and Discussion

After the connections have been verified, the prototype can be turned on as shown in Figure 6 below.



**Figure 6: Second Prototype Switched ON**

The system is able to work properly and there is no visible smoke or alarming smell after turned ON. The system after that proceed to Simcard reading from GSM module. Figure 7 below shows the GSM Module ON.

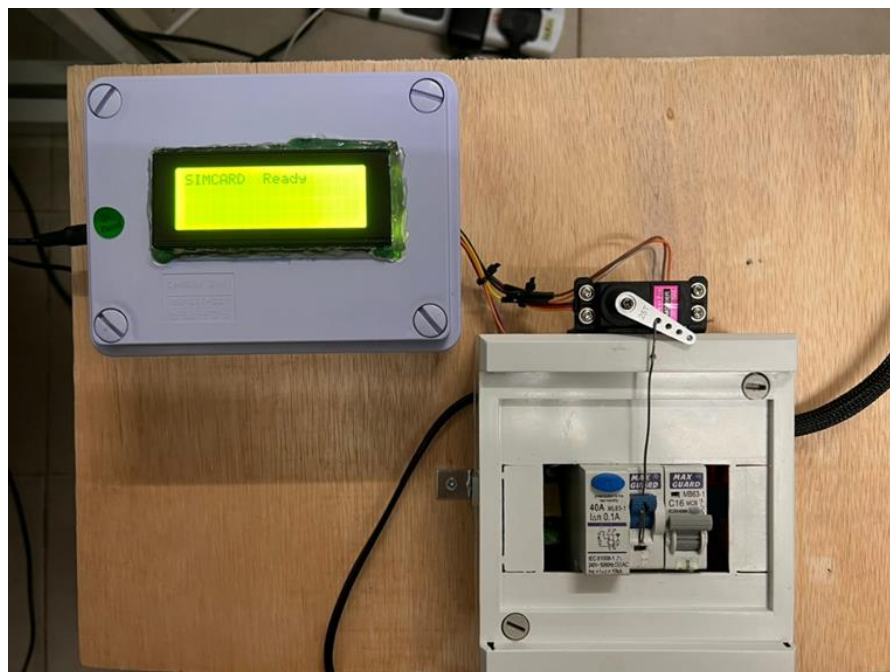

**Figure 7: GSM Module ON**

If the ZMPT101B voltage sensor detects voltage, then the system will display ELCB ON as shown in Figure 8 below.

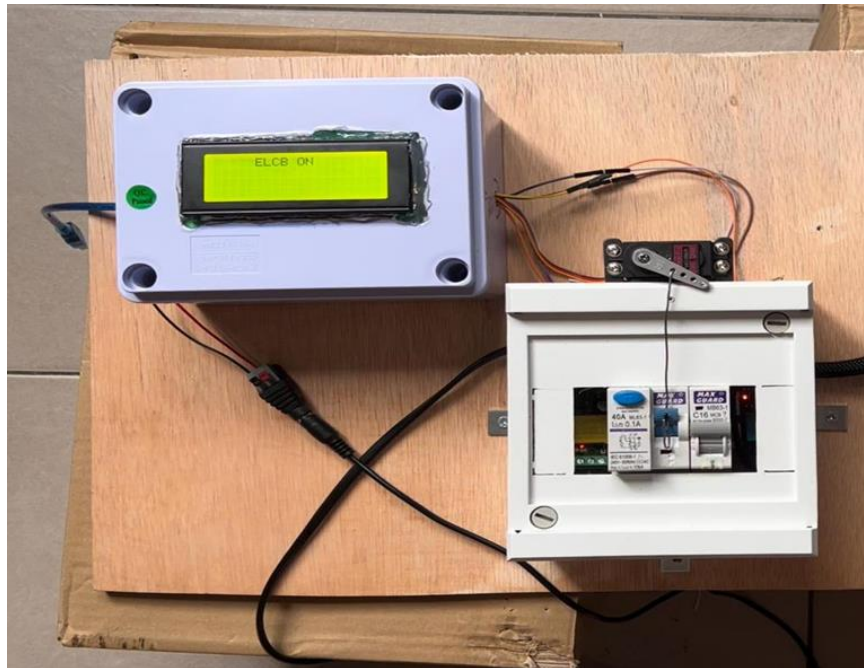

**Figure 8: ELCB ON**

If the ZMPT101B voltage sensor detects voltage less than 10V, then the system will trigger the servo motor. There will be three times attempts for the system to turn the ELCB switch. After three times of attempts, the system will display ELCB failed and GSM module will send message to the user that has been registered. Figure 9 shows the servo motor attempt to pull the ELCB switch one time.



**Figure 9: ELCB Tripped count 1**

In figure 8, the servo motor successfully pulled the ELCB switch. If the ELCB turned on, the system will display ELCB ON again as shown in figure 7 else the system will proceed to attempt until three-time attempts. Figure 10 and 11 shows second and third attempt to pull the ELCB switch.



**Figure 10: ELCB Tripped count 2**



**Figure 11: ELCB Tripped count 3**

After three times attempt, the system proceeds to final step which the system will display ELCB failed and trigger the GSM module. Figure 12 and Figure 13 shows the ELCB failed to be turned on and the GSM Module sent a message to user.





**Figure 12: ELCB Failed**

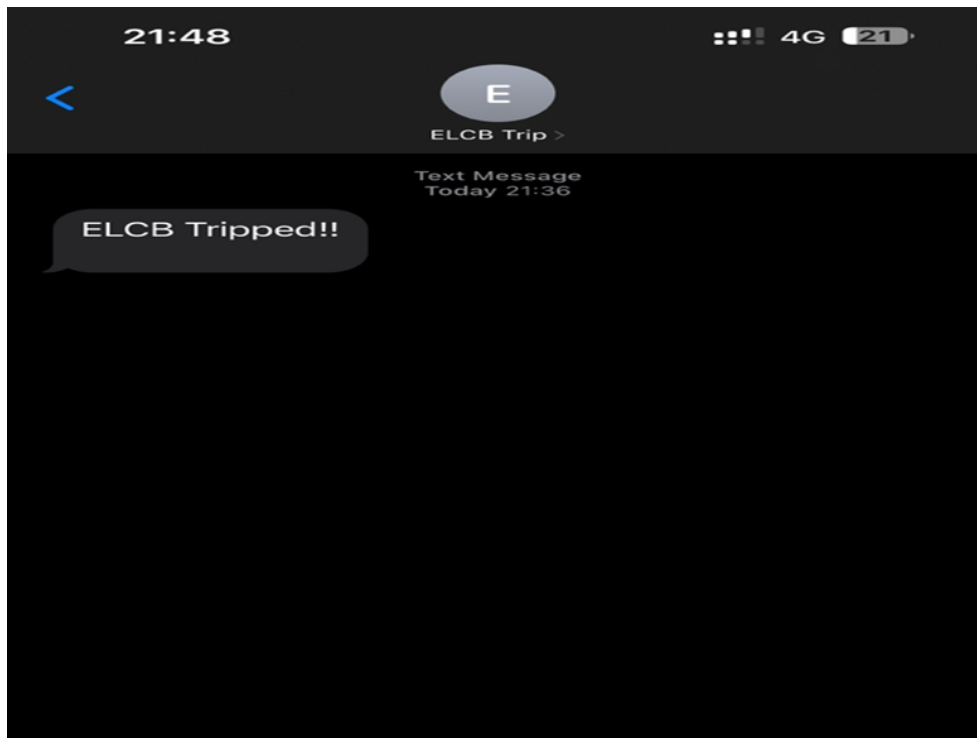

**Figure 13: Message from GSM Module**

The system will remain ELCB failed until ELCB turned back ON manually. Lastly, the system can be monitor from smartphone using ESP8266. It can monitor the output of the ELCB. Figure 14 shows the real time monitoring using Blynk App.



**Figure 14: Blynk App for monitoring**

To test if the real time monitoring is working properly, three loads have been put to check power output. Figure 15 shows the result of Steam Iron.



**Figure 15: Result of Steam Iron**

## 5. Conclusion

In conclusion, Smart Anti Trip Distribution Board is developed to reclose the ELCB and monitor the power output from the distribution board. Although the first prototype failed, the second prototype

has been tested and succeeded. The objective of the project has been archived and has given me extensive knowledge in the field of electronics, practical experience, and a beneficial influence on collaboration while producing final products and adjusting to the workplace. When a fault occurs, the system has an automatic power restoration mechanism that also has a message-to-user feature. Additionally, it has the functionality of real-time data monitoring via Blynk. Whereas user can check or examine the values of the load's energy characteristics, such as voltage, current, power, energy and frequency. For recommendation, Arduino Uno and ESP 8266 can be replaced with ESP 32 as the ESP32 is superior to the Arduino in terms of performance and the servo motor mounting can be placed from a better place to mount.

### **Acknowledgement**

The authors felt sincerely thankful and grateful to Faculty of Electrical Engineering Technology, University Tun Hussein Onn Malaysia, a sincere debt of gratitude. The thesis was made possible by his never ending tolerance, expert assistance, persistent encouragement, constant and active monitoring, constructive criticism, helpful suggestions, reading numerous subpar draughts, and fixing them at every level.

### **References**

- [1] D. I. B. Kediaman, "Garis panduan pendawaian elektrik di bangunan kediaman," Building, 2008.
- [2] ELCB (Earth Leakage Circuit Breaker), Construction, Types & Working. (September, 2021) Retrieved on June 16 from <https://www.electricaltechnology.org/2021/09/elcb-earth-leakage-circuitbreaker.html>
- [3] Ayub, M. A. M. (2014). Automatic Earth Leakage Circuit Breaker with Backup Supply (Doctoral dissertation, Universiti Tun Hussein Onn Malaysia).
- [4] Mohd Ghazali, H. (2018). Automatic ELCB Integrated with Microcontroller and GSM System.
- [5] Mehta, R., Saiyad, J., Smart, N., Mali, G., & Kamat, V. (2021, November). Development of Smart Earth Leakage Circuit Breaker Using IoT and Power Electronics. In *Journal of Physics: Conference Series* (Vol. 2089, No. 1, p. 012028). IOP Publishing.
- [6] Yi, S. S., Hud, M. H., Noh, F. H. M., Norjali, R., Sahari, N., Zulkifli, M., ... & Haw, L. K. (2020). The Smart IOT Earth Leakage Circuit Breaker with Transformerless and SMPS Auto Recloser. *Advances in Computing and Intelligent System*, 2(1).