

Smart Medicine Box with Mobile Application

**Muhammad Norizzmier Norasmawi¹, Ammar Amran¹,
Muhammad Nur Arsyad Zairul Rijaluddin¹, Nur Azliza
Ahmad^{1*},**

¹Department of Electrical Engineering, Centre for Diploma Studies,
Universiti Tun Hussein Onn Malaysia, Pagoh Higher Education Hub,
84600 Pagoh, Johor, MALAYSIA

*Corresponding Author Designation

DOI: <https://doi.org/10.30880/mari.2023.04.02.036>

Received 01 October 2022; Accepted 30 November 2022; Available online 15 January 2023

Abstract : A lot of medical issue is happened due to the facts that a lot of patients need to deal with sorting a large amount of medicine every day. This is the main reason of the project Smart Medicine Box (SMB). This prototype is used to help the patients in remembering and helping people to take medicine. Main focus of SMB is for the patients who need medical attentions more than the other. SMB is programmable through mobile application that enable the doctor to determine the schedule for the patients to take the medicine. The SMB contains twenty-one partition that have twenty-one LED for the user can set the schedule based on week. SMB will remind the patient by sending the notification through the mobile application and the LED will light up when the time for eat the medicine have come.

Keywords: Medicine, Application, Internet of Things Application (IoT)

1. Introduction

Main aim for this project is to build a SMB system for those patients that need medical attentions and regularly need to take the medicine while having a hard time to remember which medicine they should take [1]. Usually, the patients who often forget to take their medicine are due to the old age and this makes them more vulnerable because they have some disease that need them to take medicine everyday such as heart problem and diabetes [1,3]. SMB goals are to help people that have difficulty to remember their medicine intake because of health conditions. Forget and take the wrong medicine will lead to much more serious medical condition that makes the patients live with the other problem [4]. The SMB is connected via built in Bluetooth system in the ESP32 to send the notification too the patient or guardian phone.

1.1 Medicine Reminder

The main purpose for SMB is to act as a reminder not just for the patients but also for the family members. Inside each partition for the medicine there will be an LED lights that will turn on according to the schedule given by the doctors [2]. The buzzer will beep along with LED. Some patients need to

*Corresponding author: nurazliza@uthm.edu.my

take their pills regularly, because if they forget to take the medicine this may cause other medical condition. Medicine should be the one who makes the patients healthier while always having enough nutrition in their body. Patients with heart problem, diabetes, high blood pressure and elderly are more likely the one that should take their medicine regularly [5,6].

1.2 Notification System

Notification system is used to deliver attentions to the family member of the patients and the patient automatically using the built in Bluetooth system inside the ESP32 [7,8]. This project used ESP 32 as the main processor for the SMB and connect the medicine box using Bluetooth. The connection of Bluetooth to the user's phone and the family members can send notification to their phone if have any appointment or any medicine that need to take on that time. Phone notification, sound and light in the SMB is based on the schedule that have been sent. This will guide the patient to take the right medicine inside the specific partition in the SMB.

1.3 Internet of Things

All medical details of the patient are being used and collected regularly with the doctor in the applications. The applications also stored the data for what type of pills have been given and prescribed by the doctor to the patient [10]. The applications also have a feature that allows the patient to contact the doctor directly if there are any question regarding their medicines or medical conditions. The application is user friendly with clean interface throughout the application. The application also has a dedicated section for digital healthcare. For instance health related news and Doc2Us.com redirected link, so the user can ask question to doctor about health-related issues.

2. Materials and Methods

This project is conducted through waterfall scheme. Based on the waterfall scheme, there are a few steps we used for this project as shown in **Figure 1** [9].

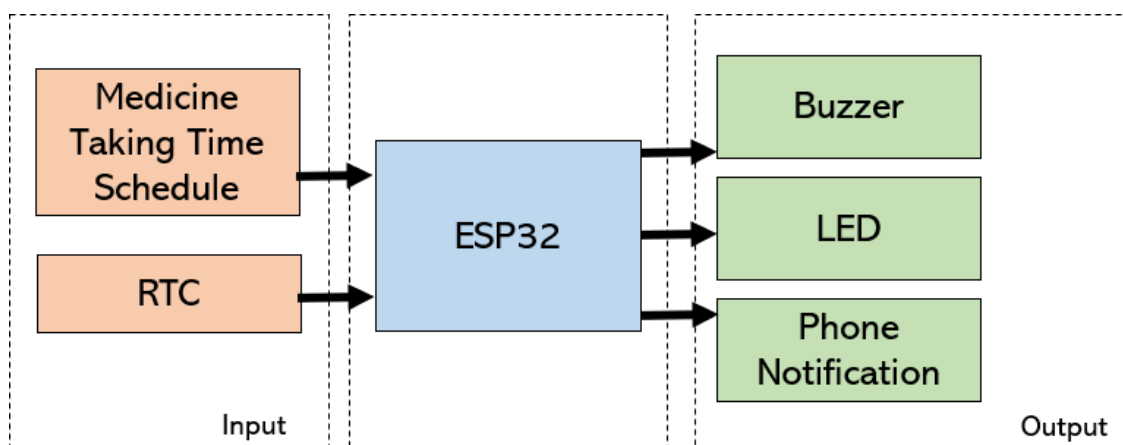

Figure 1: Block Diagram of Smart Medicine Box

Requirement: All the requirement that may be needed and important are collected and being documented in this place for specification time.

Design: After all the requirement have been studied and collected, design phase should be prepare. Design function as the specification for the component and all the system needed for the project

Implementation: Program need to be developed after all the design and requirement have been prepare before going to the next phase. Programmers used to make sure all the components and design functionality.

Testing: After finishing all the requirement, design and the implementation, all the programmers need to integrate into a system. All the system is being check to find the failures.

2.1 Requirement Project

This project have requirements steps as shown in **Figure 2** to follow in (in order of priority) as per figure:

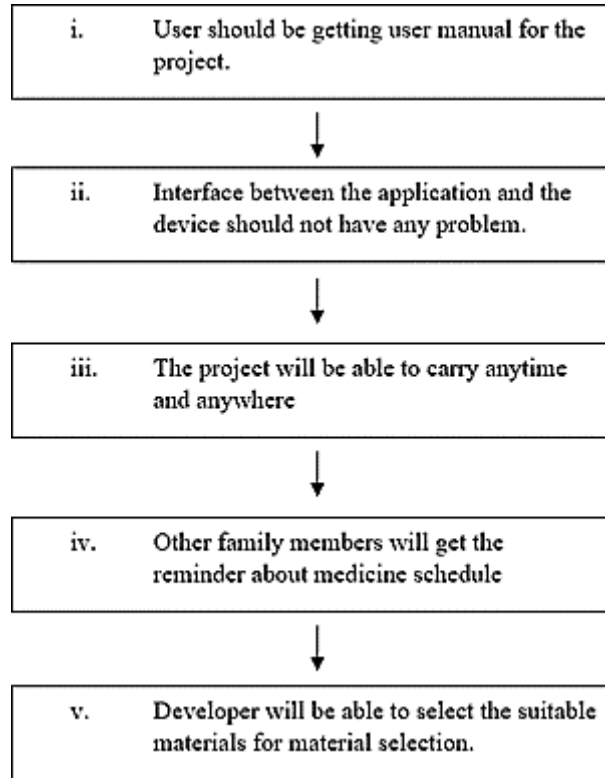

Figure 2: Requirement Project

2.1.1 ESP32 Wi-Fi Microcontroller

This project have requirements steps as shown in **Figure 2** to follow in (in order of priority) as per figure:



Figure 3: ESP32 Wi-Fi Microcontroller

ESP32 Wi-Fi Microcontroller as shown in **Figure 3** is powered by a TSMC 40nm low power 2.4 GHz dual-mode Wi-Fi and Bluetooth chip with the best power and RF features, as well as safe, reliable, and scalable applications for a wide range of applications [4].

2.2 Project Design

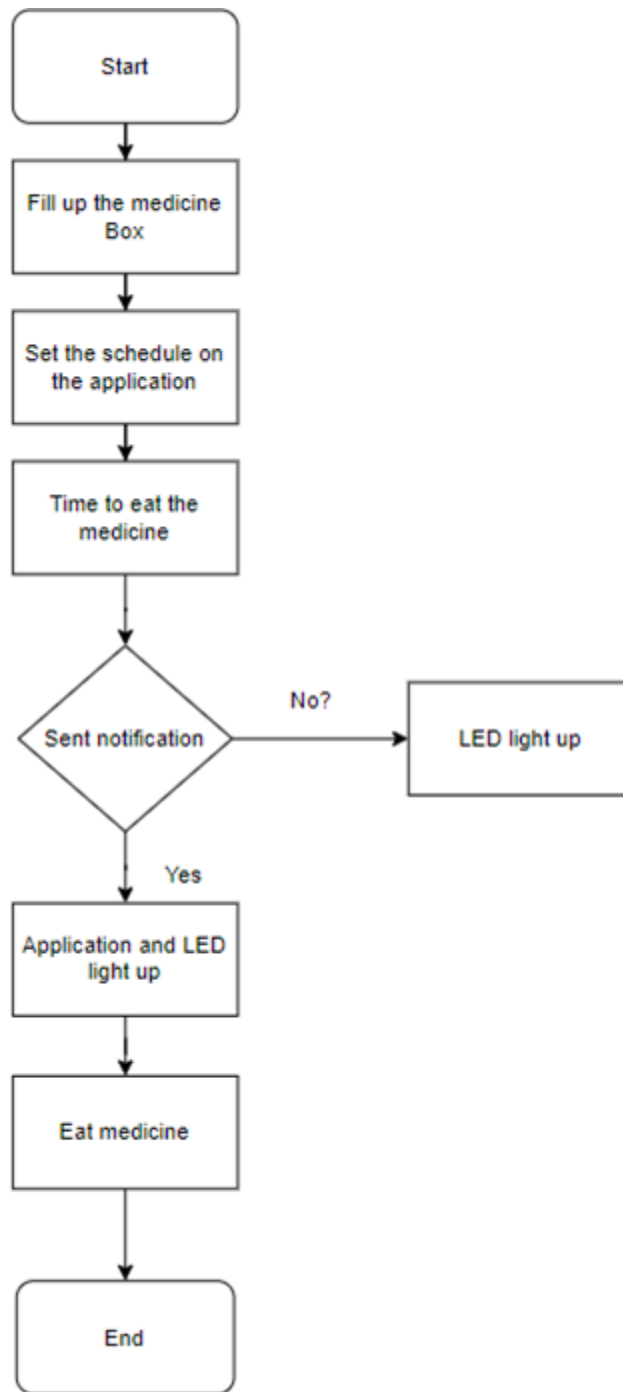

Figure 4: Flowchart of Smart Medicine Box

The project implementation process as shown in **Figure 4** is critical for ensuring that the method selected is accurate and appropriate for the product. The use of this method will aid in the prevention of complex and time-consuming processes. As a result, it is critical to carry out the method selection process. The microcontroller method was applied [8]. The project was first designed in Arduino software and then implemented directly using the listed components and materials.

2.3 Project Testing

The process of testing the tools and materials that will take place after the project is implemented during the Final Year Project 2 (FYP 2) will determine whether the tools used can work well. Following the test, it is possible to determine whether the tool used has errors or needs to be repaired. Each test is designed to examine the hardware, software, and other supporting components. **Figure 5** and **Figure 6** is a few attachments and image of our prototype testing.

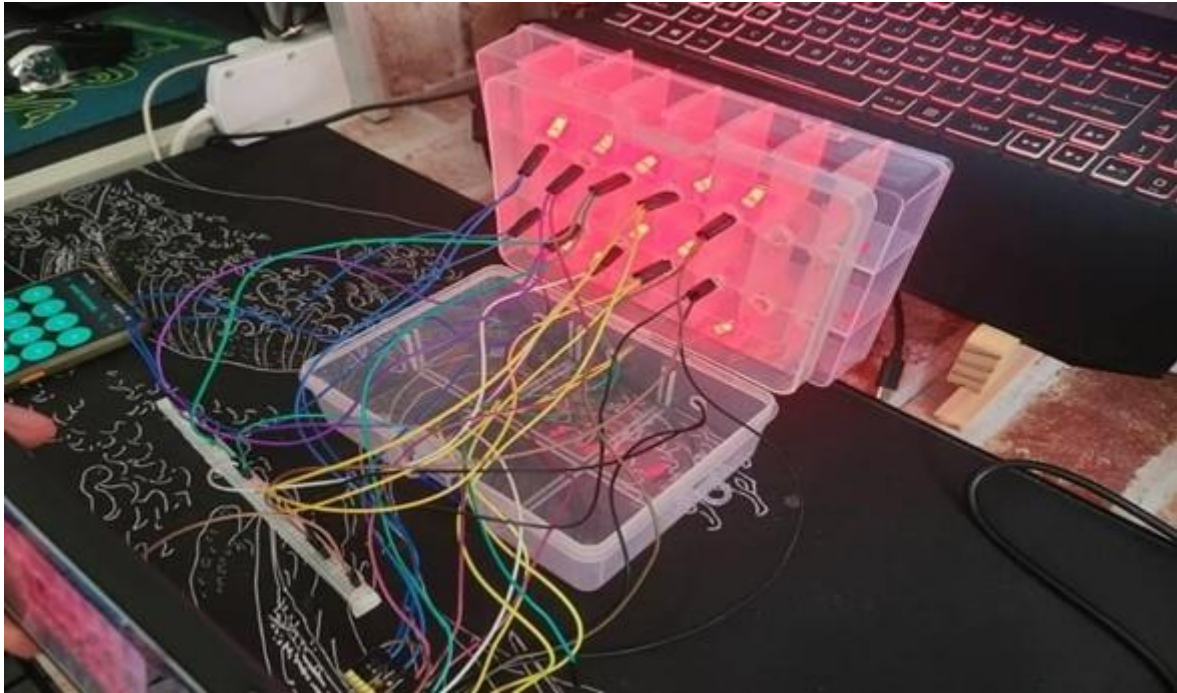

Figure 5: Prototype of The SMB

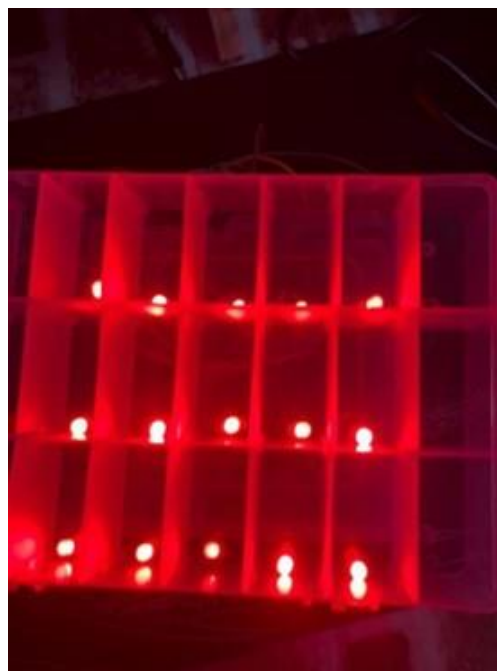

Figure 6: LED lights

3. Results and Discussion

For our result and discussion, we have made a few analyses and test based on this aspect Accuracy, Range and Limitation of the project as shown in **Table 1**.

Table 1 : Accuracy LED Light

Number of LED	Time 1 (second)	Time 2 (second)	Time 3 (second)	Average (second)
1	0.60	0.41	0.41	0.47
2	0.37	0.43	0.36	0.38
3	1.46	0.53	0.40	0.79
4	0.67	0.47	0.47	0.53
5	0.51	0.37	0.60	0.49
6	1.00	0.41	0.47	0.62
7	0.40	1.07	0.60	0.69
8	0.47	1.10	0.54	0.70
9	0.62	0.54	0.43	0.53
10	0.54	0.27	0.47	0.42
11	0.73	0.31	0.34	0.46
12	0.98	0.71	0.33	0.67
13	0.54	0.60	0.60	0.58
14	0.34	0.41	0.41	0.38
15	0.27	0.47	0.67	0.47

In the process of making this prototype, there are a few things that be able to conclude based on the tests that have been done. From Table 1, the overall accuracy for the LED lights is satisfied. The increasing number of LED lights did not affect the accuracy of the LED when receive signal from the mobile application. The Figure 7 shows that the dark point on the graph denotes a data point. A data point on a line graph represents the average time of LED lights that matches a particular time in the x-axis. The accuracy is around 0.4 seconds to 0.8 seconds, which is good because it is not more than 1 second. In the graph shown, the number of average times in the number of LEDs 3 is 0.79 seconds. Similarly, in the number of LEDs 10 is 0.42 seconds.

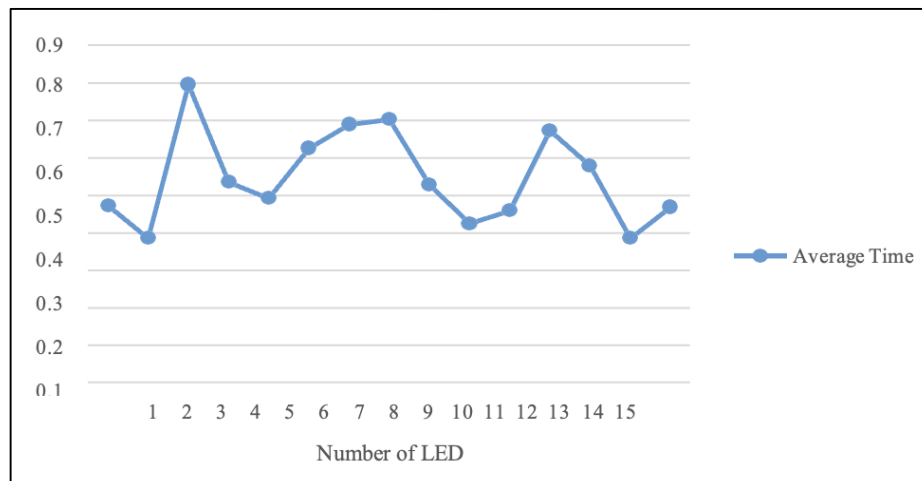

Figure 7: Graph of Accuracy LED Light

For the second test, the aim is to test the capability of our prototype in certain range. The tests weredone in range of 5m, 10m, 15m, 20m, 25m, and 30m as shown in **Table 2**. From the tests, the conclusion is the range for ourprototype is at a reasonable rate. The prototype able to achieve from

range 5 meter until 15 meter using the hotspot from the mobile phone. The prototype fails to reach the distance 20 meter to 30 meter using mobile hotspot. By using much narrower wavelength, Wi-Fi with 5 GHz is more compatible to using around the house which didn't being interrupted to any obstacle around the house. Based on this, the prototype can hold onto longer range if use Wi-Fi router that able to transmit Wi-Fi on larger scale.

Table 2: Range Between Medicine Box and Wifi

Distance(m)	Connectivity
5	✓
10	✓
15	✓
20	✗
25	✗
30	✗

Table 3: LED Output

Number of LED	Output
1	✓
2	✓
3	✓
4	✓
5	✓
6	✓
7	✓
8	✓
9	✓
10	✓
11	✓
12	✓
13	✓
14	✓
15	✓
16	✗

For the third test, the focus is to test the limit based on the processor for this prototype. Originally the prototype was supposed to use 21 LED in the medicine box but been discovered that ESP 32 only has 15 working pins that were able to use as an output. This made us decide to use 15 LED instead of 21 LED in this prototype. Based on the limitation testing, the conclusion is the result of this test is at satisfactory level. All the 15 LED lit up based on the schedule that we set without any problem as shown in **Table 3**.

4. Conclusion

SMB is a prototype that are needed and demanded by the elderly. Its helps people to take care a patient anywhere and anytime. Its will be very helpful as the medical assistant for the patient. SMB very compatible to bring anywhere. By using the results from the test that have been done, this prototype can be enhanced even further by using much powerful processor and incorporating artificial intelligence elements to the doctors and patient. The accuracy for this prototype is good because it didn't take a long time to send the notification to the application. By using the Wi-Fi module, this prototype can be use anywhere around the house. The purpose for project is to explain about the problem that patients often having. Time saving and reminder is an advantage for medical assistance by having this prototype. This prototype is believed would help user to improve their life quality.

Acknowledgement

The authors would like to thank the Centre for Diploma Studies, Universiti Tun Hussein Onn Malaysia for its support.

References

- [1] R.Hashime, L. Sears, and A. Bahrami, "An Android Based Medication Reminder System: A Concept Analysis Approach," in *Conceptual Structures for Discovering Knowledge*, vol. 6828, S. Andrews, S. Polovina, R. Hill, and B. Akhgar Eds. Berlin, Heidelberg: Springer Berlin Heidelberg, 2011, pp.315-322
- [2] P. Gupta, D. Agrawal, J. Chhabra, and P. K. Dhir, "IoT based smart healthcare kit," in *2016 International Conference on Computational Techniques in Information and Communication Technologies (ICCTICT)*, 2016: IEEE, pp. 237-242
- [3] S. Banka, I. Madan, and S. Saranya, "Smart healthcare monitoring using IoT," *International Journal of Applied Engineering Research*, vol. 13, no. 15, pp. 11984-11989, 2018
- [4] V. B. Sree, K. Indrani, and G. M. S. Latha, "Smart medicine pill box reminder with voice and display for emergency patients," *Materials Today: Proceedings*, vol 33, pp.4876-4879, 2020
- [5] G. Latif, A. Shankar, J. M. Alghazo, V. Kalyanasundaram, C. Boopathi, and M. Arfan Jaffar, "I- CARES: advancing health diagnosis and medication through IoT," *Wireless Network*, vol. 26, no. 4, pp. 2375-2389, 2020
- [6] Minaam, Diao Salama Abdul, and Mohamed Abd-ELfattah. "Smart drugs: Improving healthcare using smart pill box for medicine reminder and monitoring system." *Future Computing and Informatics Journal* 3.2 (2018): 443-456.
- [7] Zanjali, Samir V., and Girish R. Talmale. "Medicine reminder and monitoring system for secure health using IOT." *Procedia Computer Science* 78 (2016): 471-476.
- [8] Pang, Zhibo, Junzhe Tian, and Qiang Chen. "Intelligent packaging and intelligent medicine box for medication management towards the Internet-of-Things." *16th international conference on advanced communication technology*. IEEE, 2014.
- [9] Aldeer, Murtadha, and Richard P. Martin. "Medication adherence monitoring using modern technology." *2017 IEEE 8th Annual Ubiquitous Computing, Electronics and Mobile Communication Conference (UEMCON)*. IEEE, 2017.
- [10] Najeeb, PK Nijiya Jabin, et al. "Pill care-the smart pill box with remind, authenticate and confirmation function." *2018 International Conference on Emerging Trends and Innovations In Engineering And Technological Research (ICETIETR)*. IEEE, 2018.