

Bird-Repellent Machine: Reducing Birds' Feces

Daniel Aiman Mohd Ruzaimi¹, Ahmad Raees Rafiq Iqbal¹, Ahmad Syakir Ahmad Sufian¹, Hairul Mubarak Hassim^{1,2*}

¹ Department of Mechanical Engineering, Centre for Diploma Studies, Universiti Tun Hussein Onn Malaysia, Pagoh Higher Education Hub, Pagoh, 84600, MALAYSIA

² Product research and development (ProRED), Centre for Diploma Studies, Universiti Tun Hussein Onn Malaysia, Pagoh Higher Education Hub, 84600, Pagoh, Johor, MALAYSIA

*Corresponding Author: hairulm@uthm.edu.my

DOI: <https://doi.org/10.30880/mari.2025.06.01.032>

Article Info

Received: 01 October 2024

Accepted: 30 November 2024

Available online: 15 January 2025

Keywords

Mechanical Birds Repellent, Bird Dropping

Abstract

Bird feces significantly impact urban environments, contributing nutrients beyond the needs of algal biomass, resulting in high phosphate concentrations. Traditional bird repellent methods, such as chemicals and physical barriers, often prove ineffective and environmentally harmful. This project addresses the increasing challenge of bird-related disturbances in urban areas, exacerbated by a projected 200% rise in urbanization by 2030. A non-lethal, affordable Mechanical Bird Repellent that employs sound and light to deter birds, aiming to reduce avian waste on vehicles and outdoor surfaces by 50% is produced. Utilizing a 3D-printed body made from ABS and PLA for strength and environmental friendliness, the device integrates a PIR sensor, buzzers, and LED lights. These components activated upon detecting bird movement, creating a sensory overload to the birds that safely repel the birds. Field installation in Pagoh, Johor demonstrated the device's effectiveness, with reductions of more than 50% of bird droppings over two days duration. This innovative solution not only enhances public cleanliness and health by minimizing exposure to harmful bird droppings but also promotes enjoyment of outdoor areas. The project represents a significant advancement in urban wildlife management, providing a practical, efficient, and humane method to maintain cleaner and safer environments.

1. Introduction

The bird feces provide nutrients for the needs of the algal biomass throughout the vegetation period. High concentrations of phosphate are found in bird feces. These high concentrations resulted in a low ratio of nitrogen to phosphorous. Ammonia was always the dominating inorganic nitrogen compound and only during the period of maximum algal growth in the spring were considerable amounts of nitrate found [1].

Primary bird repellents act as irritants or unpalatable flavor cues that produce a congenital avoidance response by birds [2]. Repellents are tools used by humans to manipulate animal behavior. Therefore, the tool can be thought of as a communication device that sends a signal from which the animal extracts a message. Critical to the design of any tool is a careful consideration of form and function, such that when used, its action is efficient in producing the desired effect [2]. Primary repellents can function as unconditioned stimulus (the aversive experience) and can be used to condition animals to avoid associated sensory cues.

However, because primary repellents have a direct and immediate adverse consequence, animals tend to limit their exposure to the agent. Thus, the magnitude of the unpleasant experience is generally less than would

be achieved by the poisoning effect of a typical secondary repellent. Hence, the acquisition and persistence of avoidance response to the associated sensory cues is generally diminished relative to situations when secondary repellents are used [3].

As urbanization increases, wild animals, especially birds, adapt to city environments [4], [5]. By 2030, urbanization is expected to rise by 200%. Birds thrive in urban areas due to abundant food and waste, creating health and environmental hazards [6], [7], [8], [9]. Traditional bird repellent methods, such as chemicals and fences, often lose effectiveness and can harm the environment [10], [11]. Modern solutions use IoT and Edge Computing for wildlife control, like audio alarms and laser signals to scare birds away [12], [13], [14].

This project aims to design an affordable, non-lethal bird repellent machine that uses sound to reduce bird waste on properties, protecting cars, motorcycles, and outdoor benches from damage. Bird repellents offer a practical solution to this problem. These devices typically use sound to deter birds, making them uncomfortable and encouraging them to leave the area. While bird repellents are usually employed by farmers to protect crops from being eaten by birds, they can be adapted for general use in urban and suburban settings.

The Mechanical Bird Repellent developed in this project is designed to reduce avian waste by 50%. This versatile device can be installed in various locations to meet specific needs. It activates when a bird lands on any part of its antenna, providing an effective deterrent without causing harm to the birds. The primary goal of this project is to minimize the amount of bird droppings on vehicles and other surfaces. By reducing the overall number of birds in trees, the repellent helps maintain cleaner and safer environments. Furthermore, this project aims to ensure public health and hygiene by minimizing exposure to harmful bird droppings. Achieving these goals will result in cleaner public spaces, improved health outcomes, and enhanced enjoyment of outdoor areas. The Mechanical Bird Repellent represents a significant step towards solving the problem of bird droppings in urban environments, providing a practical and effective solution for maintaining public cleanliness and safety.

2. Methodology

The 3-Dimensional drawing and the bill of material (BOM) for the bird-repelling machine is shown in **Fig. 1**. It showcases a meticulous blend of design and functionality aimed at efficiently deterring avian intruders. The body and cover of the machine are 3D printed using a combination of ABS (Acrylonitrile Butadiene Styrene) and PLA (Polylactic Acid). The material is selected for their complementary properties of strength, durability, and environmental friendliness. The electrical components, sourced separately, are carefully chosen for optimal performance and reliability. These components are intricately integrated and housed securely within the body of the machine, forming a robust circuit consisting of a PIR sensor as the movement detector as well as buzzers and LED lights responsible for activating the device. When operational, this circuit ensures that the machine functions seamlessly, providing a reliable deterrent against birds. This thoughtful integration of advanced materials and precise engineering results in a bird-repelling solution that is both effective and enduring, ready to protect any designated area from avian interference.

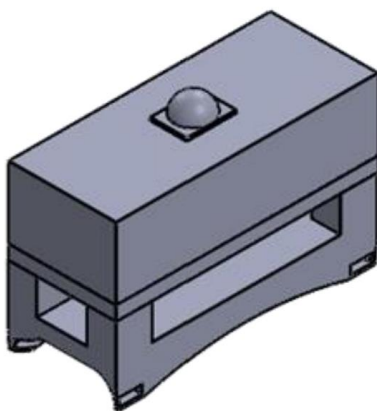

(a)

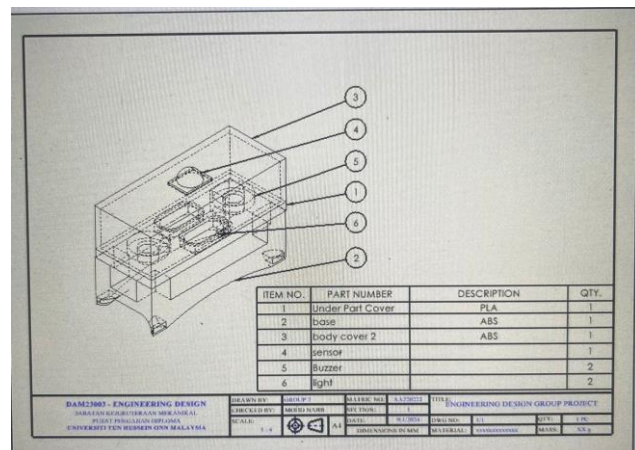

(b)

Fig. 1 Drawing of product (a) 3 Dimension drawing (b) Bill of materials

2.1 Project System

The body of the bird-repelling machine serves several crucial functions, essential for the device's effectiveness and durability. Designed with a bottom that fits well onto trees, it ensures stable and secure installation, preventing the machine from being easily dislodged by wind or bird activity. The body is constructed from ABS, a material chosen for its exceptional strength and high heat resistance, making it suitable for enduring the outdoor elements. Manufactured using a 3D printer, the body is precisely engineered to provide an optimal fit and reliable performance. The main function of the body is to protect the internal circuit from environmental disturbances, such as rain, dust, and extreme temperatures. This protective role ensures that the machine operates consistently and remains durable over time, maintaining its ability to effectively repel birds in various weather conditions.

2.2 Circuit System

The circuit of the bird-repelling machine is designed to effectively utilize a 12V power source to activate deterrent mechanisms upon detecting a bird. The components of the circuit systems are as follows:

- Power supply: The machine is powered by a 4.5V power source, which serves as the primary energy provider for the entire circuit.
- Sensor connection: This 4.5V power source is connected to a sensor, which is responsible for detecting the presence of birds.
- Sensor output: Upon detecting a bird, the sensor outputs a voltage of 3V.
- Power distribution: Once the relay is activated, it allows the 4.5V power source to power a 3V light and supplies power to a 3V buzzer.

In summary, when a bird is detected by the sensor, the 3V signal activates the 3V light and 3V buzzer to operate simultaneously. This coordinated response effectively scares away the birds. The circuit diagram is shown in **Fig. 2**.

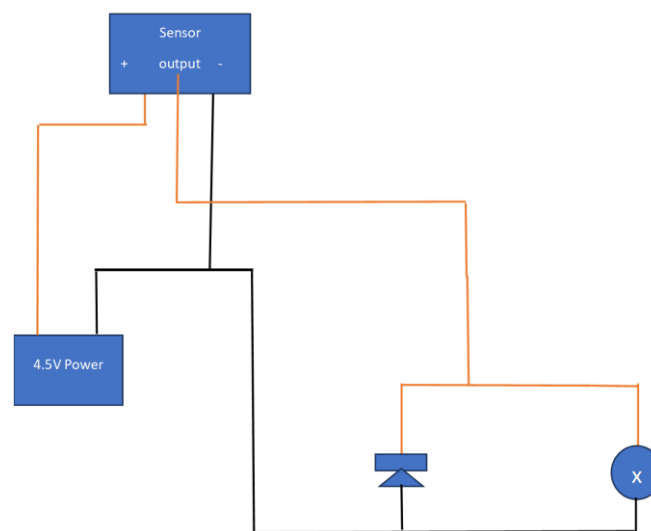

Fig. 2 Electrical circuit of the bird repelling machine

2.3 Experimentation

The final product of the bird-repelling machine is shown in **Fig. 3(a)**. The product is installed on a tree located in Pagoh, Johor as in **Fig. 3(b)**. The innovative device is specifically designed to safeguard the area from bird-related disturbances through its advanced features and strategic placement. The machine is equipped with a highly sensitive motion detector positioned on top, engineered to detect any bird flying within its range. Upon detection, the machine promptly activates, triggering both a powerful light and a loud buzzer. The simultaneous activation of these deterrents creates a sensory overload that effectively scares the birds away, ensuring they do not linger or return.

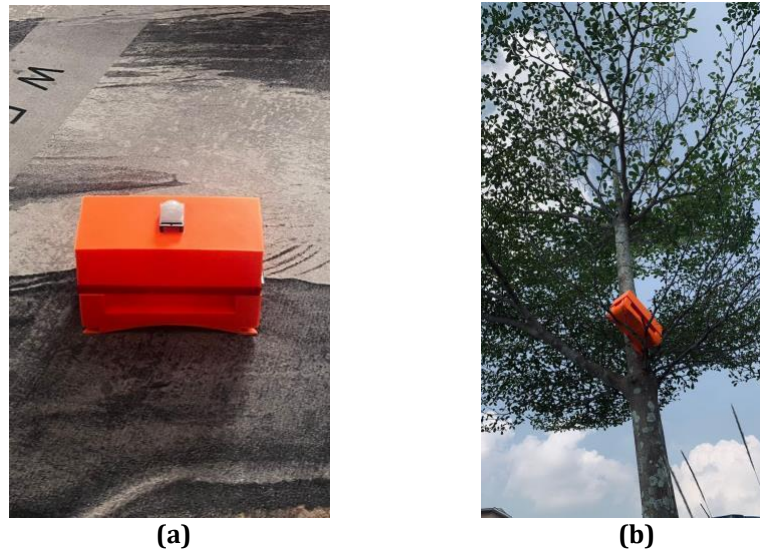

Fig. 3 Product of bird-repellent machine (a) Final product (b) Product hanging on tree

This dual-action mechanism is not only efficient but also humane, as it discourages birds without causing them harm. The careful installation atop a tree maximizes the machine's coverage area, protecting not just the tree itself but also its immediate surroundings from avian interference. The thoughtful design and responsive technology ensure that the bird-repelling machine operates reliably, providing continuous protection and peace of mind for those in the vicinity. This device exemplifies a harmonious blend of technology and practicality, making it an invaluable asset for maintaining bird-free zones in designated areas in Pagoh, Johor.

3. Result and Discussion

A tree where birds like to rest on it was identified. A black cardboard was placed below of the tree and quantity of birds' feces were recorded for two consecutive days. Next, the bird-repelling machine was installed and a black cardboard is also placed at the same location as previous. The quantity of birds' feces were also recorded for two consecutive days.

Fig. 4 shows the birds feces on black cardboard without and with the use of bird-repellant machine while **Fig. 5** shows that quantity of the feces recorded for each day. Without installing the bird-repelling machine, it was found that the quantity of the feces for the first and second day are 9 and 12 respectively. The total number of feces without the bird-repelling machine is 21. Upon installing the bird-repelling machine, the quantity of the feces reduces to 4 for the first day and 5 for the next day. The total birds' feces for the two days is 9. The results show that the product can reduce the birds' feces by more than 50%. This proved that the product can increase the effectiveness of bird repellent currently used commercially.

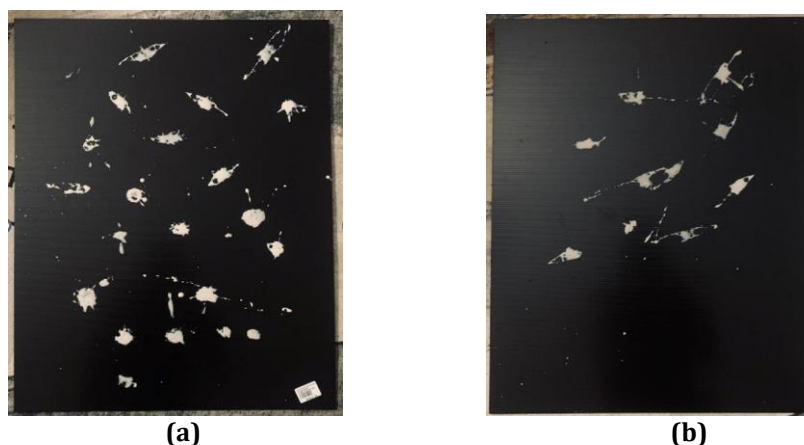

Fig. 4 Birds feces on black cardboard (a) Without bird-repellent machine (b) With bird-repellent machine

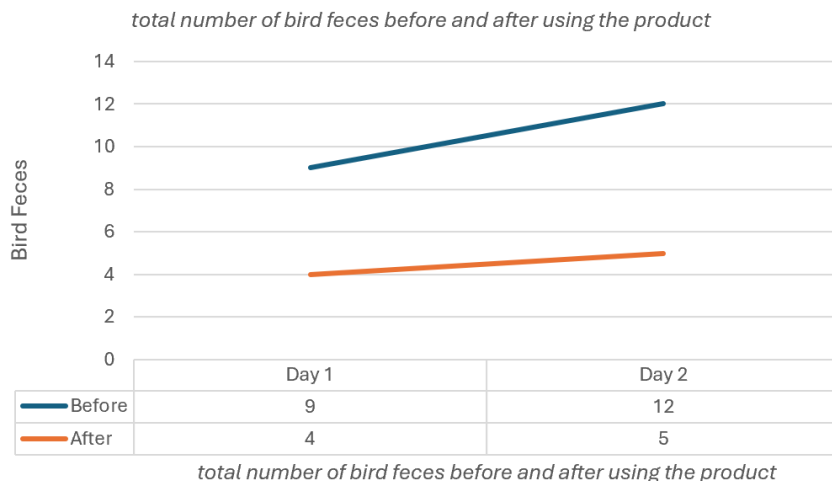

Fig. 5 Quantity of birds' feces in two days duration

4. Conclusion

Bird droppings influence the urban habitats by providing nutrients that are beyond what algal biomass requires causing high levels of phosphate. Unfortunately, chemical and physical means of bird repellent are frequently inefficient and ecologically adverse. This project aims at combating the rising cases of bird-human conflicts which are likely to increase given the projected rate of urbanization of 200% by 2030.

The efficiency of the device was affirmed after a field installation at Pagoh, Johor where the device's efficiency decreased bird droppings within two days. Also, the application of this creative solution leads to improved sanitation and health of the population as well as their preference for outdoor spaces since they will not encounter dangerous bird droppings. This project protects public health and hygiene since people avoid contracting diseases from bird droppings and leads to clean appearance of public places, higher health status and increased appreciation of avian environments. Mechanical Bird Repellent can be regarded as an extraordinary solution of the problem of bird droppings in the urban spaces, as it is efficient and offers practical ways of preventing birds' defecation therefore preserving public cleanliness and security.

Acknowledgement

The author would like to express his gratitude for the support provided by all parties and Centre of Diploma Studies, Universiti Tun Hussein Onn Malaysia.

Conflict of Interest

Authors declare that there is no conflict of interest regarding the publication of the paper.

Author Contribution

The authors acknowledge the contributions to this paper as follows: **conception and design of the study** : Daniel Aiman Mohd Ruzaimi, Ahmed Raees Rafiq Iqbal , Ahmad Syakir Ahmad Sufian, Hairul Mubarak Hassim ; **data collection**: Daniel Aiman Mohd Ruzaimi, Ahmed Raees Rafiq Iqbal , Ahmad Syakir Ahmad Sufian; **analysis and interpretation of results**: Daniel Aiman Mohd Ruzaimi, Ahmed Raees Rafiq Iqbal , Ahmad Syakir Ahmad Sufian, Hairul Mubarak Hassim; **manuscript draft preparation**: Daniel Aiman Mohd Ruzaimi, Ahmed Raees Rafiq Iqbal , Ahmad Syakir Ahmad Sufian, Hairul Mubarak Hassim. All the authors reviewed the results and approved the final version of the manuscript.

References

- [1] B. Ganning, F. Wulff, and B. Ganning, "The effects of bird droppings on chemical and biological dynamics in brackish water rockpools," *Oikos*, vol. 20, no. 2, p. 274, 1969. doi: 10.2307/3543194.
- [2] L. Clark, "Physiological, ecological, and evolutionary bases for the avoidance of chemical irritants by birds," in *Current Ornithology*, vol. 14, Plenum, NY, 1998, pp. 1-37.
- [3] E. V. Aronov and L. Clark, "Degradation studies of the non-lethal bird repellent, methyl anthranilate," *Pestic. Sci.*, vol. 47, pp. 335-362, 1996.
- [4] E. L. Moreno, J. Clos, K. Pan. (2016). World Cities Report 2016," *UN-Habitat* [Online]. Available: <https://digitallibrary.un.org/record/1323272>.

- [5] E. Koomen, M. S. van Bommel, J. van Huijstee, B. P. J. Andrée, P. A. Ferdinand, and F. J. A. van Rijn, "An integrated global model of local urban development and population change," *Comput. Environ. Urban Syst.*, vol. 100, p. 101935, Mar. 2023, doi: 10.1016/J.COMPENVURBSYS.2022.101935.
- [6] M. Chaves *et al.*, "Wildlife is imperiled in peri-urban landscapes: threats to arboreal mammals," *Sci. Total Environ.*, vol. 821, May 2022, doi: 10.1016/J.SCITOTENV.2021.152883.
- [7] W. A. Chaves, D. Valle, A. S. Tavares, T. Q. Morcatty, and D. S. Wilcove, "Impacts of rural to urban migration, urbanization, and generational change on consumption of wild animals in the Amazon," *Conserv. Biol.*, vol. 35, no. 4, pp. 1186–1197, Aug. 2021, doi: 10.1111/COBI.13663.
- [8] D. R. Prihandi and S. Nurvianto, "The role of urban green space design to support bird community in the urban ecosystem," *Biodiversitas*, vol. 23, no. 4, pp. 2137–2145, 2022, doi: 10.13057/BIODIV/D230449.
- [9] J. N. Zeyl *et al.*, "Infrasound hearing in birds: a review of audiometry and hypothesized structure–function relationships," *Biol. Rev.*, vol. 95, no. 4, pp. 1036–1054, Aug. 2020, doi: 10.1111/BRV.12596.
- [10] C. W. Lee *et al.*, "Anti-adaptive harmful birds repelling method based on reinforcement learning approach," *IEEE Access*, vol. 9, pp. 60553–60563, 2021, doi: 10.1109/ACCESS.2021.3073205.
- [11] M. Sharmila F, C. K. Amal Kumar, A. Varsha D, and E. Sarayu, "Animal repellent system for smart farming using AI and edge computing," in *Proc. 8th Int. Conf. Adv. Comput. Commun. Syst. (ICACCS)*, 2022, pp. 1439–1441, doi: 10.1109/ICACCS54159.2022.9785126.
- [12] R. Yauri, A. Castro, R. Espino, and S. Gamarra, "Implementation of a sensor node for monitoring and classification of physiological signals in an edge computing system," *Indones. J. Electr. Eng. Comput. Sci.*, vol. 28, no. 1, pp. 98–105, Oct. 2022, doi: 10.11591/IJEECS.V28.I1.PP98-105.
- [13] R. Yauri, "IoT edge device to estimate breathing rate from ECG signal for continuous monitoring," *Proc. 2022 IEEE Eng. Int. Res. Conf. (EIRCON)*, 2022, doi: 10.1109/EIRCON56026.2022.9934805.
- [14] R. Chen, X. Wang, J. Wang, C. Duan, and X. Zhang, "Application of small nano-laser electronic fence combined with ultrasonic bird repellent device to monitor bird damage on power transmission lines," in *Proc. 2022 4th Int. Acad. Exch. Conf. Sci. Technol. Innov.*, Mar. 2023, pp. 184–187, doi: 10.1109/IAECST57965.2022.10061967.