

Portable Air-Cooler System

Hariz Aiman, Muhammad Athari, Nur Syahirah, Nor Baizura Hamid

*Department of Civil Engineering, Centre for Diploma Studies,
Universiti Tun Hussein Onn Malaysia/Pagoh Higher Education Hub, 84600 Pagoh, Johor, MALAYSIA*

*Corresponding Author: norbaizura@uthm.edu.my
DOI: <https://doi.org/10.30880/mari.2025.06.02.013>

Article Info

Received: 31 August 2024
Accepted: 31 December 2024
Available online: 20 February 2025

Keywords

Portable Air Cooler System, Global Warming, Temperature, Digital Multimeter, Infrared Thermometer

Abstract

Malaysia, a tropical country, is seeing economic progress while dealing with growing issues caused by global warming. This study looks into how the need for air conditioning is affected by rising temperatures and how solar energy is being adopted as a sustainable alternative. With Malaysia's climate, solar power is very promised as a practical way to reduce energy shortages and environmental degradation. The project intends to create an affordable solar-powered portable air cooler, test its viability indoors, and measure the voltage and current output of the solar panel for optimal performance. Tests of voltage and temperature were conducted under various sun circumstances. The data shows a stable temperature decrease over the observed periods (from 10:00 am to 2:20 pm), with decreases of approximately 3.3% to 3.6% from the initial temperature values. This pattern may be influenced by changes in weather conditions or other environmental factors affecting temperatures at that time. Peak temperatures and solar energy output were measured at noon. An average of 6.64V was found during voltage measurements, indicating that the air cooler had enough power. Overall, the solar-powered air cooler shows strong cooling performance in hot weather, confirming its environmental sustainability and operational success. This project demonstrates how Malaysia may use solar energy to lessen its reliance on fossil fuels, reduce its carbon footprint, and combat climate change. This report promotes sustainable approaches to steer Malaysia toward a more environmentally friendly energy landscape while striking a balance between economic growth and environmental stewardship.

1. Introduction

Malaysia, positioned near the equator, experiences a consistently hot and humid climate due to its direct exposure to the sun's rays. Despite its economic progress, the country faces significant environmental challenges, particularly global warming. This is driven by natural factors like solar intensity fluctuations and human activities such as open burning and the use of lead-containing petrol, all contributing to rising temperatures.

This study examines how Malaysia is impacted by increasing global temperatures and changing climate patterns, focusing on two key sectors: air conditioning usage and the adoption of renewable energy sources, notably solar power. Solar energy, among other renewable sources of energy, is a promising and freely available energy source for managing long-term issues in the energy crisis [1]. Solar power generation relies on solar radiation received at the earth's surface, which is primarily governed by deterministic diurnal and seasonal cycles and is significantly altered by uncertain cloud and aerosol variations [2]. With rising temperatures, there's a greater demand for air conditioning to maintain comfort levels, leading to higher energy consumption and

environmental strain. Simultaneously, there's a growing interest in transitioning to cleaner energy sources like solar power to reduce reliance on fossil fuels and mitigate environmental harm.

The rising temperatures present significant challenges for Malaysia, particularly in terms of increased reliance on air conditioning, which strains energy resources and exacerbates environmental degradation. This underscores the need for implementing energy-efficient practices and exploring cleaner energy alternatives. Conversely, the adoption of renewable energy technologies like solar power offers Malaysia an opportunity to move towards a more sustainable energy landscape. The development and use of renewable energy sources can enhance diversity in energy supply markets, contribute to securing long-term sustainable energy supplies, help reduce local and global atmospheric emissions, and provide commercially attractive options to meet specific energy service needs [3]. Additionally, renewable energy technologies provide an excellent opportunity for mitigation of greenhouse gas emissions and reducing global warming through substituting conventional energy sources [4].

Given the urgency of the climate crisis, Malaysia stands at a critical juncture where it can prioritize both environmental sustainability and economic prosperity. Transitioning to renewable energy sources, particularly solar power, not only helps mitigate environmental pollution but also brings economic benefits such as cost savings and improved energy security. Operation maintenance costs of a solar cooling system are low when compared to the initial capital cost [5]. By focusing on areas like air conditioning usage and renewable energy adoption, the objectives of this study are to develop a more cost-effective and efficient portable air cooler, evaluate its temperature suitability for indoor uses, and determine the voltage and current produced by a solar panel to power the cooler. Solar power has been shown to lower operating costs, offset grid electricity use, and demonstrate corporate social responsibility [6].

In conclusion, Malaysia's response to rising global temperatures and changing climate patterns requires a balanced approach that considers both environmental and economic factors. As we can see, solar energy is considered to be one of the most potential alternative energy resources because of its free, pollution-free, and abundant reserves [7]. Through the adoption of sustainable practices and the promotion of renewable energy solutions, Malaysia can navigate toward environmental resilience and long-term economic prosperity. This research aims to develop a more cost-effective and efficient model of portable air cooler, evaluate the air cooler's temperature capability to confirm that it is suitable for use, and ascertain the voltage current generated by the solar panel to effectively power the air cooler.

2. Methodology

The methodology of this study shows the flow of work required to meet the study's objectives. It was carried out by the flowchart shown in Fig. 1.

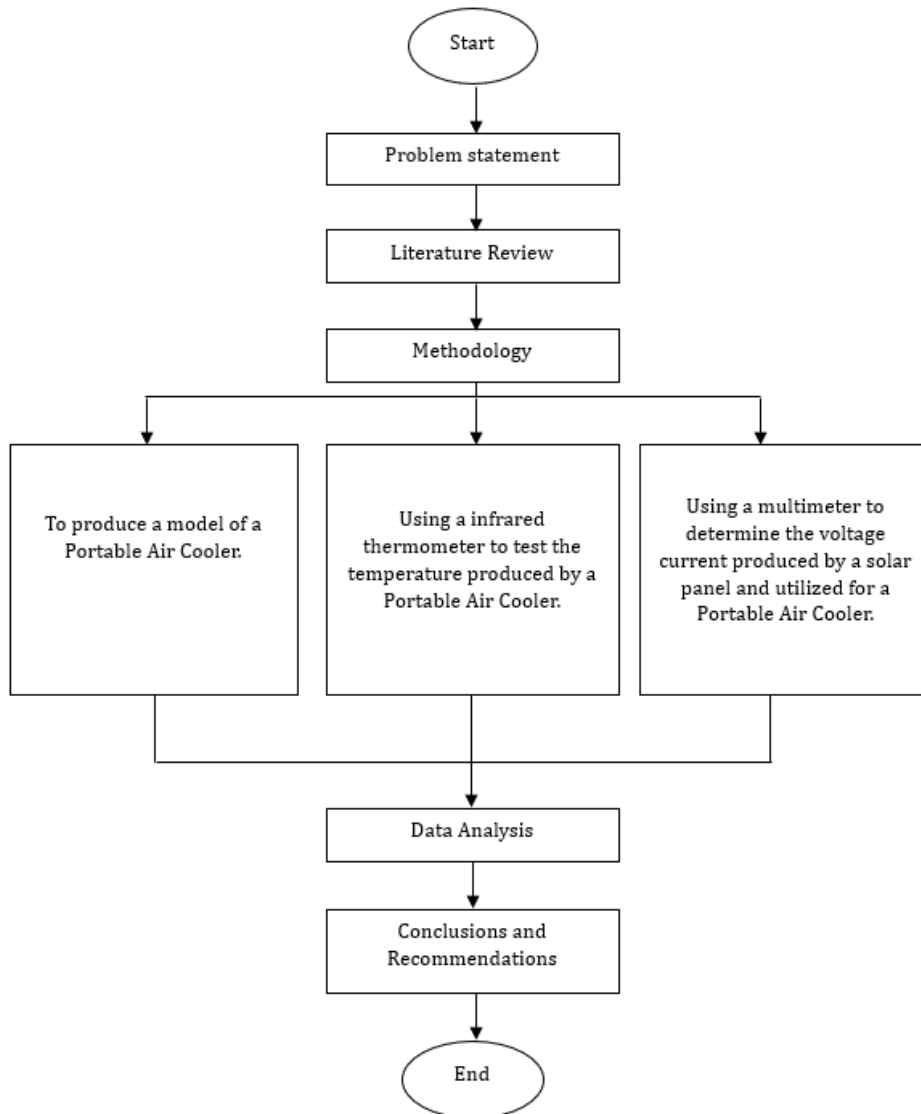

Fig. 1 Flowchart of the study

2.1 Materials

The materials used in this study for the portable air cooler are solar panels, wheels, on/off switches, solar batteries, DC fans, and acrylic plastic panels. Solar panels are the main functional components of this model. The output voltage used is 12V, the power output is 2W, and it measures 110mm x 136mm. The design concept for the system of models is depicted in Fig. 2.

This model was designed using engineering software, which is AutoCAD 2023. It is designed with solar as the main medium for obtaining electrical power to cool the room during hot weather. Solar batteries will be charged under the sun and placed in the battery socket on the air cooler model. This model is simple and wheeled to allow it to be moved, and it is designed to provide comfort to users while utilizing sustainable energy sources. The model size measures 210 x 297 mm, commonly known as A4 size in international paper standards.

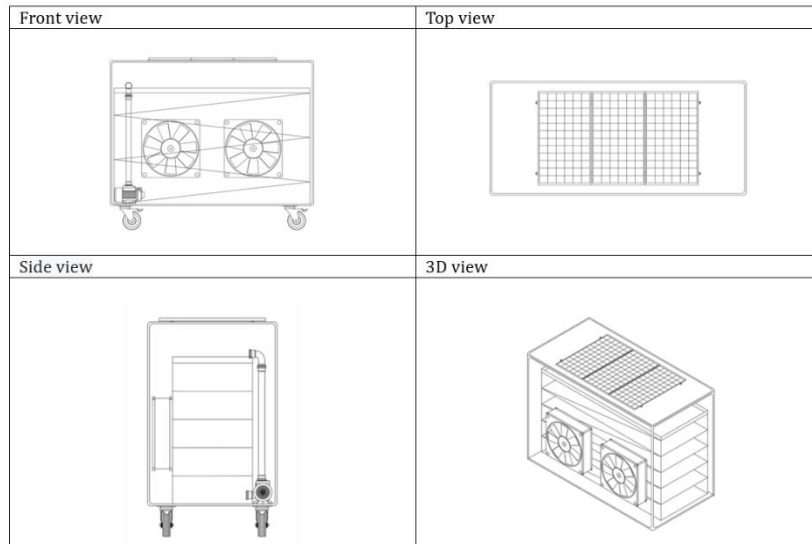

Fig. 2 Schematic Diagram of the proposed Model

2.2 Methods

2.2.1 Design of Portable Air Cooler

Fig. 3 shows the development process for the portable air cooler model. The development process for the portable air cooler model involves designing, prototyping, testing, and refining to optimize cooling efficiency and portability.

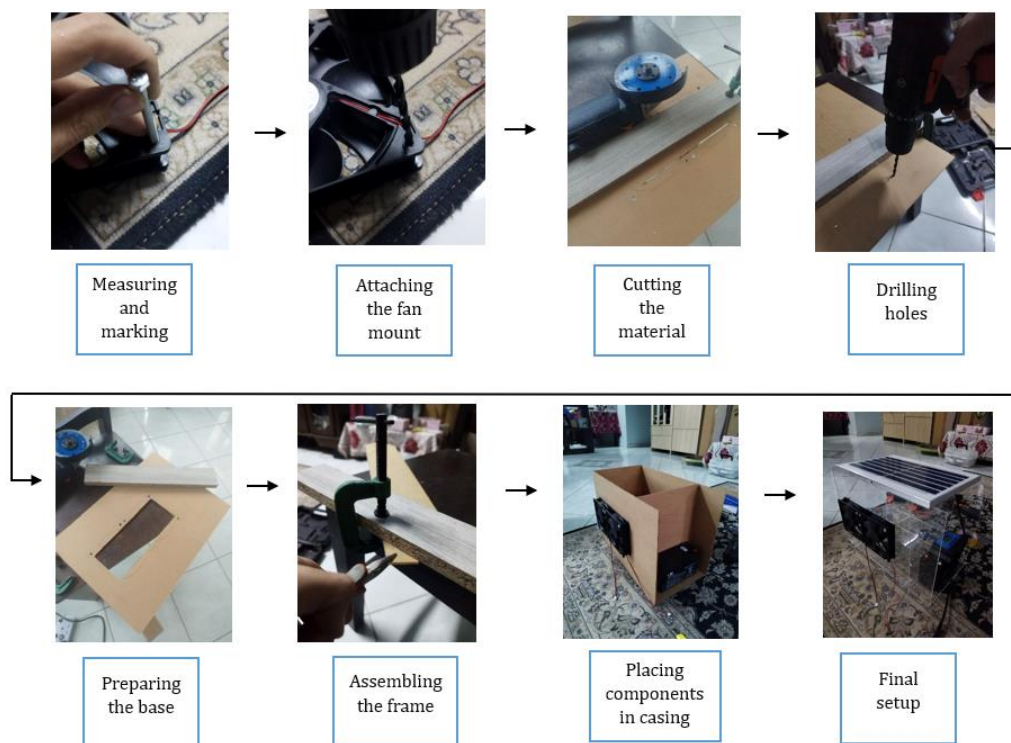

Fig. 3 Process of Development for the Portable Air Cooler Model

2.2.2 Temperature Testing of Portable Air Cooler

Data was collected at three times: at 10:00 am, at noon, and 2:00 pm. After using the system for 20 minutes, the temperature began to decrease (see Table 1 for details).

2.2.3 Voltage Testing of Portable Air Cooler

A multimeter was used to test the voltage of a portable air cooler system. The average reading value is calculated by taking three readings and the test was taken three times. This test was carried out by detecting the temperature at 9 am (see Table 2 for details).

3. Result and Discussion

3.1 Temperature Test

Table 1 shows the value of the temperature reading before and after 20 minutes of the system was applied. In the data provided, at 10:00 am, the temperature was recorded at 27.8°C, which then dropped to 26.8°C by 10:20 am. This indicates a temperature decrease of 1.0°C for over 20 minutes, or approximately 3.6% from the initial value. This change suggests a stable temperature decrease during that interval.

At noon, the temperature was 27.4°C, which decreased to 26.5°C by 12:20 pm. This shows a temperature decrease of 0.9 °C for over 20 minutes, or about 3.3% from the initial temperature. This pattern indicates a gradual, yet significant temperature decreases during the midday period. Later, at 2:00 pm, the temperature was recorded at 27.6°C, which then dropped to 26.6°C by 2:20 pm. A temperature decreases of 1.0 °C occurred over 20 minutes, or approximately 3.6% from the initial value. This pattern shows a consistent temperature decrease during the afternoon period.

Overall, the data shows a stable temperature decrease over the observed intervals, with temperature decreases of about 3.3% to 3.6% from the initial values during each period studied. This pattern may be influenced by changes in weather conditions or other environmental factors affecting temperature at that time.

Table 1 Temperature Value at Different Times

Time	Temperature °C	Percent of Decreasing (%)
10:00 am	27.8	
10:10 am	27.2	3.6
10:20 am	26.8	
12:00 pm	27.4	
12:10 pm	27.0	3.3
12:20 pm	26.5	
2:00 pm	27.6	
2:10 pm	27.1	3.6
2:20 pm	26.6	

Fig. 4 shows the comparison of the decreasing temperature reading in percent. The temperature differences indicate that during morning and evening hours, the temperature decreases more effectively for the portable air cooler's cooling process due to lower ambient temperatures outside, which aids in lowering room temperatures. The data shows a stable temperature decrease over the observed periods, with decreases of approximately 3.3% to 3.6% from the initial values during each period studied. This pattern may be influenced by changes in weather conditions or other environmental factors affecting temperatures at that time.

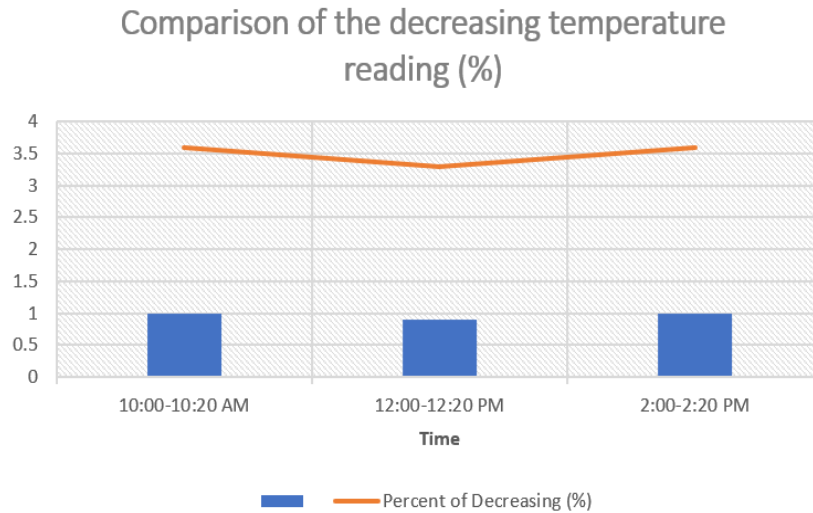

Fig. 4 Comparison of the Temperature Reading

3.2 Voltage Test

Referring to Table 2, the average reading for the voltage test has been taken over three readings at noon. The voltage-current test resulted in an average reading of 6.64V, indicating that the solar panel's ability to capture sunlight can generate enough energy to run the portable air cooler. Comprehending the voltage levels requires knowledge of the measurements' timing. As the measurements were made at noon, the greatest solar intensity is obtained when the sun is usually at its highest point in the sky. Sunlight is usually at its highest during midday, which allows the solar panels to absorb more energy. This clarifies the comparatively high average voltage of 6.64 V at noon. As seen by the voltage readings, the solar panel's ability to convert solar energy into electrical energy is directly improved by increasing exposure to sunshine.

Table 2 Voltage Readings

Reading	Voltage (V)
First	6.84
Second	6.68
Third	6.40
Average	6.64

4. Conclusion

Overall, the conclusion that can be drawn is that the objective was successfully achieved. Performance tests demonstrate that even in hot temperatures, this air cooler can effectively cool off. The product's capacity to effectively reduce indoor temperature demonstrates that it achieves its primary goal of making the user comfortable. The portable air cooler project has successfully demonstrated its effectiveness across multiple dimensions and operates efficiently using solar energy, making it eco-friendly and energy-efficient. Leveraging solar power, not only reduces dependence on conventional energy sources but also helps mitigate carbon emissions, aligning with global climate change mitigation efforts. The versatility of this portable air conditioner also enhances its appeal and practicality for various applications.

Furthermore, performance tests have indicated that the air conditioner effectively cools in hot weather conditions. A consistent temperature reduction of around 3.3% to 3.6% was observed during testing, highlighting its ability to efficiently lower ambient temperatures. Additionally, voltage tests showed an average reading of

6.64V at midday, demonstrating the solar panel's capacity to generate adequate power for operating the air conditioner. These findings underscore the product's primary objective of ensuring user comfort.

This prototype represents an initial version, with potential future improvements including scaling up to enhance voltage output and cooling capacity. Moreover, the air conditioner's design prioritizes cost-effectiveness, ensuring accessibility across different segments of society. Extensive research and development efforts have ensured that the product not only performs well but also delivers significant economic value to users.

In summary, the portable air cooler meets all the criteria established in this study. Its technical efficiency, environmental sustainability, user adaptability, and economic viability position it as a successful innovation. This instills confidence in its potential for widespread commercialization and broad societal benefits. Thus, this project stands as a significant accomplishment in providing eco-friendly and efficient cooling solutions.

Acknowledgment

The authors would like to thank the Centre for Diploma Studies (CeDS), University Tun Hussein Onn Malaysia for their support. In addition, a heartfelt thank you to all team members for their dedication to the project and mutual support in making it a success.

Conflict of Interest

Authors declare that there is no conflict of-interests regarding the publication of the paper.

Author Contribution

*The authors confirm contribution to the paper as follows: **study conception and design:** Nor Baizura Hamid; **data collection, analysis, interpretation of results, draft manuscript preparation:** Hariz Aiman Hadi Abd. Munir, Muhammad Athari Mohammad Zaidi, Nur Syahirah Mat Nawi. All authors reviewed the results and approved the final version of the manuscript.*

References

- [1] S. K. Sahoo, "Renewable and sustainable energy reviews solar photovoltaic energy progress in India: A review," *Renewable and Sustainable Energy Reviews*, vol. 59, pp. 927-939, June 2016.
- [2] H. Jiang, N. Lu, L. Yao, J. Qin, T. Liu, "Impact of climate changes on the stability of solar energy: Evidence from observations and reanalysis," *Renewable Energy*, vol. 208, pp. 726-736, May 2023.
- [3] V. Devabhaktuni, M. Alam, S. S. S. R. Depuru, R. C. Green II, D. Nims, C. Near, "Solar energy: Trends and enabling technologies," *Renewable and Sustainable Energy Reviews*, vol. 19, pp. 555-564, March 2013.
- [4] N. L. Panwar, S. C. Kaushik, S. Kothari, "Role of renewable energy sources in environmental protection: A review," *Renewable and Sustainable Energy Reviews*, vol. 15, no. 3, pp. 1513-1524, 2011.
- [5] T. Otanicar, R. A. Taylor, P. E. Phelan, "Prospects for solar cooling—An economic and environmental assessment," *Solar energy*, vol. 86, no. 5, pp. 1287-1299, May 2012.
- [6] K. Ukoba, K. O. Yoro, O. Eterigho-Ikelegbe, C. Ibegbulam, T. C. Jen, "Adaptation of solar power in the Global south: Prospects, challenges and opportunities," *Heliyon*, Mar 2024.
- [7] G. Wang, Z. Zhang, J. Lin, "Multi-energy complementary power systems based on solar energy: A review," *Renewable and Sustainable Energy Reviews*, vol. 199, pp. 114464, 2024.