

## Chili Picker Tool

**Muhammad Adam Sufi Mohd Safri, Muhammad Aiman Haqimie Mohd Jamil, Muhammad Adib Akmal Mohd Hafiz, Khairulnizam Othman\***

*Department of Mechanical Engineering, Centre for Diploma Studies, Universiti Tun Hussein Onn Malaysia, Pagoh Higher Education Hub, 84600 Pagoh, Johor, MALAYSIA*

\*Corresponding Author: [nizam@uthm.edu.my](mailto:nizam@uthm.edu.my)

DOI: <https://doi.org/10.30880/mari.2024.05.03.022>

### Article Info

Received: 01 March 2024

Accepted: 31 July 2024

Available online: 31 December 2024

### Keywords

Chili Picker Tool, Harvesting  
Efficiency, Manual Labor Reduction,  
Agricultural Innovation, Crop  
Preservation, Increased Profitability

### Abstract

This paper presents the design and development of a chili picker tool aimed at revolutionizing the chili harvesting process. The tool improves efficiency, productivity, and reduces manual labor in agriculture. Materials and machines used in creating the tool are carefully selected for quality and functionality. Inspired by the mechanism of a hair clipper, the chili picker tool incorporates a horizontally moving blade to break the chili's pedicle. This mimics the way farmers pluck chilies with their thumbs, which also move horizontally. To determine the optimal force required to break the pedicle, the study investigates the characteristics of bird's eye chilies. An equation is derived to calculate the power produced by the DC motor, enabling determination of the cutting force needed. Experimental results show comparable performance to conventional methods, with suggestions for improving motor speed and torque. The chili picker tool has significant potential impact. By reducing reliance on manual labor, it offers a more efficient and productive alternative to traditional harvesting methods. This innovation addresses the labor-intensive nature of chili farming, minimizes crop damage, and boosts profitability for farmers. It also preserves the chili plant, allowing for continued growth and potential increased yields. The fresher and better-conditioned chilies harvested with the tool may fetch higher prices in the market. In conclusion, the chili picker tool has the potential to transform chili harvesting by providing a more efficient, productive, and sustainable alternative to manual labor. Further improvements are suggested, but this tool offers a realistic option to optimize chili farming, increase profitability, and meet culinary industry demands.

## 1. Introduction

Chili peppers are a popular crop with high demand in the culinary industry. However, harvesting chili peppers is a time-consuming and labor-intensive procedure that frequently necessitates manual plucking by farm employees [1]. The traditional method of handpicking not only offers efficiency and productivity issues but also raises the danger of plant and harvested produce damage. The creation of a revolutionary chili picker tool has emerged as a possible approach to solve these problems and optimize the chili harvesting process [2].

The development of the chili picker addresses several challenges faced by farmers and suppliers in the selection and harvesting of ripe chillies. These challenges include time constraints during overlapping seasons, making it difficult to collect all the peppers efficiently. The primary objective of designing this red pepper picker is to simplify the vertical-axis chilli picking process, aiming to resolve the issues encountered by farmers and

suppliers. To ensure the smooth operation of the project, extensive testing and analysis in real-world scenarios involving farmers or suppliers are crucial. The picker not only enhances efficiency by allowing immediate harvesting but also addresses concerns related to productivity, operating costs, and worker safety during the harvest. By reducing time wastage and ensuring uniform picking, the tool promises significant long-term impacts on productivity, time, and cost-effectiveness. Its lightweight design, ease of component replacement, and applicability in various chilli clusters contribute to its practicality, making it a valuable and safe tool for farm use [3].

Based on the population statistics collected by the Federal Agricultural Marketing Authority (FAMA) from the official website named Portal Rasmi Jabatan Pertanian [4], the data presented indicates a 7.2% increase in the chili crop area by the state in 2017 compared to 2021. While the population of Malaysian people also increase by about 0.2% which is 32.7 million people in 2021 compared to 32.6 million in 2021. Therefore, the increasing number of people in Malaysia affects the number of producers of chillies in Malaysia. Those producers are decreasing in 2018 because of certain problems while cultivating their chillies farm. Anim Agro Technology website states that some problems that chillies encountered are pests, bacteria, and a lack of technical skills [5]. Even though there are fewer producers, they have discovered a new method for making a lot of chillies quickly.

The main purpose of this project is to design a prototype that can help chili farmers harvest their chili faster. Other than that, to make the harvesting process more convenient, user-friendly, and efficient. Lastly, the scope of this project is focused on bird-eye chili types and chili farms that use fertigation systems to harvest chillis. Based on the population statistics collected by the Federal Agricultural Marketing Authority (FAMA) from the official website named Portal Rasmi Jabatan Pertanian, the data presented indicates a 7.2% increase in the chili crop area by the state in 2017 compared to 2021. In Malaysia, the conventional approach is typically followed for vegetable marketing, involving multiple intermediaries in the process, which leads to elevated marketing expenses. Factors such as inputs, the adoption of contemporary technology, labor, and household size have been identified as key influencers of resource utilization efficiency. The findings regarding food security indicate that a larger proportion of farmers face food insecurity compared to those who have secure access to food [6].

## 2. Materials and Methods

**Table 1** *Material list*

Name	Quantities	Uses
Hollow	1(125mm)	Body part
Mild steel plate	2(1.2 mm)	Blade part
DC motor	1	To rotate the blade
Rechargeable battery	1	Supply power
Button	1	Switch on/off
Charger	1	To charge the battery
Thin cylinder steel	4	To make frame
rope	2	To make handle
Net	2	To catch chili

When considering a mechanical material and method for your final year project, several factors come into play to ensure success. The choice of material should align with your project's objectives and requirements. Common materials include metals like aluminum or steel, polymers, and composites, each offering specific advantages in terms of strength, weight, and cost. The selection should also consider environmental factors and safety, adhering to project constraints. Table 1 outlines the materials selected for the project and their respective properties.

In terms of methods, consider your project's scope. Testingping, computer simulations, and experimental testing are common approaches. Utilize CAD software to design and analyze your project, ensuring it meets technical specifications. When moving to the physical realm, ensure rigorous testing, measurement, and data analysis, emphasizing repeatability and reliability. Collaborate with professors and professionals and adhere to project guidelines to choose the right materials and methods. Careful consideration and planning will pave the way for a successful final year project in the mechanical field.

In the realm of mechanical projects, the selection of appropriate methods plays a pivotal role. Considering the scope, integrating prototyping, computer simulations, and experimental testing is vital. Employing Computer-Aided Design (CAD) software is instrumental in crafting a meticulous design and conducting a thorough analysis, ensuring adherence to technical specifications. Transitioning from virtual designs to the physical prototype requires meticulous testing, measurements, and data analysis. Prioritize repeatability and reliability in these endeavors, collaborating with experts to select suitable materials and methodologies. This strategic approach and attention to detail form the cornerstone of a successful final-year mechanical project.

**Table 2** *Machine tools used*

Name	Uses
Grinder	Cutting materials
MIG machine	Welded the materials
Manual bender	Bend the materials
3D printed	Make a plastic part

The fabrication process involves working with different materials and techniques. Grinding mild steel plates for blades is expedited with a grinder, ensuring efficiency and precision. Some metal parts may be bent without machinery, while certain components necessitate the use of plastic due to size constraints or other considerations. Table 2 has been updated to include the machinery and tools used in conjunction with the selected materials. Adherence to safety protocols during equipment usage is paramount to avoid injuries. Accurate measurements are crucial to prevent errors between parts, particularly in welding thin cylinders, where technique is essential to prevent damage.

Fig. 1 illustrates the 3D design crafted using SolidWorks for the proposed project. The assembly includes diverse components such as the body, cap, push-button switch, switch mechanism, micro metal gear motor, holding plate, crank head, crank roller, and blade yoke. With plastic as the primary material, accommodating both the motor and a rechargeable battery, the design ensures optimal functionality. The motor, operating at low RPM, provides high torque, and the rechargeable battery guarantees long-term usability. Components 7 and 6 are specifically tailored for cutting pedicle chilies, showcasing the detailed and purposeful design of the project.

The assembly of the proposed project involves the integration of various components, each serving a specific function. The micro metal gear motor, a critical element, operates at a low RPM yet delivers substantial torque, providing the necessary power for the cutting mechanism. This motor is strategically positioned within the assembly to ensure optimal functionality. The cutter, comprising components 7 and 6, is intricately designed for precision cutting of pedicle chilies. The design of the cutter and its attachment to the motor is a focal point, requiring careful consideration to achieve the desired cutting efficiency. The parts, including the holding plate, crank head, crank roller, and blade yoke, are assembled in a cohesive manner to ensure the seamless operation of the entire system.

As with any mechanical assembly, the consideration of vibrations is paramount. Vibrations can adversely impact the precision and efficiency of the cutting mechanism. During the assembly process, the tolerance and clearances between components must be meticulously managed to minimize vibrations. Additionally, the choice of materials plays a crucial role in dampening vibrations. Anti-vibration mounts or dampers may be incorporated into the design to further mitigate the impact of vibrations. Ensuring a robust and stable assembly is essential for the longevity and reliable operation of the cutting tool. Regular testing and refinement of the assembly may be necessary to fine-tune its performance, accounting for real-world conditions and potential variations in operating environments.

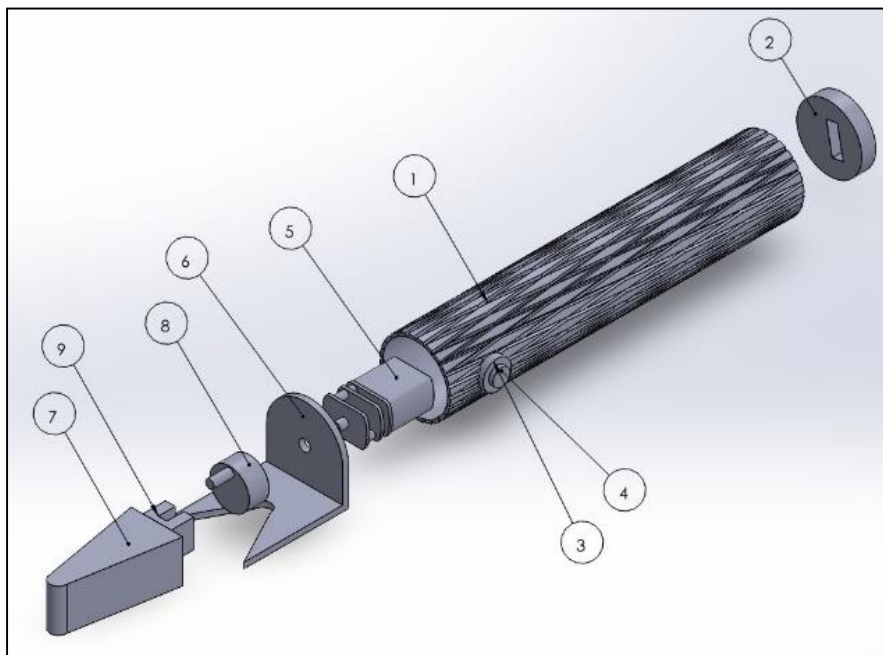

Fig. 1 Chili Picker SolidWorks Drawing

The method we use is to pluck the chili by using the mechanism of a hair clipper. This is because the hair clipper cuts the hair with a blade that moves horizontally, the same as the mechanism of plucking chilies used by farmers. The farmers pluck chilies with their thumbs that move horizontally. Fig. 2 illustrates the pepper picking method, where a V-shaped cutter with a specific design shape selector is employed. Data collection involves determining the fracture rate from the bottom or from an appropriate angle based on the branch and the size of the fruit stem.



**Fig. 2** The thumb moves horizontally to pluck the chili

Our tool also works the same which the blade that breaks the chili's pedicle will move horizontally. In order to break the pedicle, there are certain forces that we need. The question is how much force is to break the pedicle. The amount of power necessary to pluck a chili pepper varies based on factors such as the bud's maturity, the tightness of its connection to the plant, and individual differences in strength and technique. However, in general, bird's eye chilies are small and have thin stems when compared to larger chili species. As a result, they take less force to pluck than larger peppers. Without using too much power, you should be able to extract a ripe bird's eye chili from the plant with a delicate tug or pinch.

**Table 3** EMG measurement

	Right hand	Left hand
Thumb	107.2 N	109.7 N
Index finger	58.4 N	61.3 N

An EMG (Electromyography) device is utilized to measure the forces exerted by fingers, as in Table 3. By capturing and analyzing the electrical activity generated by the muscles during finger contractions, EMG devices provide valuable data on finger forces. These measurements aid in understanding finger movements, muscle activation patterns, and assessing hand function. EMG technology plays a crucial role in various fields such as rehabilitation, ergonomics, and biomechanics. It enables researchers and clinicians to gain insights into the intricate dynamics of finger forces, facilitating the development of innovative solutions for hand-related conditions, optimizing ergonomic designs, and advancing our knowledge of human motor control.

$$F_G = \frac{mg}{\mu} \times s \quad (1)$$

$F_G$  is arithmetic sum (N)

$m$  is workpiece weight (kg)

$g$  is gravitation ( $9.81 \text{ m/s}^2$ )

$a$  is acceleration ( $\text{m/s}^2$ ) = 0

$S$  is safety factor = 2

$\mu$  is coefficient of friction (stell on steel "slightly oiled") = 0.1

Specification = 337 N

Acting force per finger = 168.3 N

Example calculation of handling weight

$$m = \frac{F_G(\mu)}{g(s)} = \frac{337(0.1)}{9.81(2)} = 1.718 \text{ kg} \quad (2)$$

Specification of recommended handling weight = 1.718 kg based on a friction-locked connection. To provide a calculation for a chili picker tool using a single clipper triangle, specific details about the dimensions and design of the tool are necessary. The cutting force required to break the chili's pedicle depends on factors such as the chili's stem thickness, hardness, and the desired efficiency of the tool. Conducting experiments or referring to existing research can help estimate the force needed.

Once the cutting force is determined, the power required by the motor can be calculated. This calculation involves considering factors such as the mechanical advantage of the clipper triangle, efficiency losses, and friction. The formula for power is  $P = F \cdot v$ , where  $P$  represents power,  $F$  is force, and  $v$  denotes the velocity of the blade.

In order to operate the tool effectively, it is essential to select an appropriate motor based on the power calculation. Factors such as motor speed, torque, and efficiency need to be considered during the motor selection process. Additionally, the clipper triangle should be designed to align the blades in a way that enables efficient cutting of the chili pedicles. The dimensions and angles of the blades will depend on factors such as chili size, shape, and stem thickness.

To assess the tool's performance, efficiency, and ergonomic factors, it is advisable to develop a prototype of the chili picker tool with the clipper triangle design and conduct testing on actual chili plants. Based on the results, necessary adjustments can be made to enhance its functionality. It is important to note that this overview provides a simplified understanding, and for more accurate and effective design, consultation with experts in mechanical engineering or agricultural technology is recommended.

In this Eq. 3, calculate the power generated by the DC motor in terms of its rpm (rotations per minute) which is 60 rpm.

$$P = F(v) = 337(1) = 377 \text{ Watt} \quad (3)$$

Torque (in Newton-meters) required to cut the chili pedicle with a precise force, as determined by Eq. 4.

$$T = \frac{P}{2\pi s} = \frac{377}{2\pi(10)} = 59.99 \text{ Nm} \quad (4)$$

Where:

$T$  is Torque (Nm)

$P$  is Power (Watt)

$S$  is Speed (rpm)

The power output of 380 Watts is adequate for severing the chili pedicle. This power is achieved by a motor running at 60 rpm and generating a torque of approximately 60 Nm, as calculated using Eq. 4. It's important to note that equation 4 is used to calculate the torque, and Eq. 3 is applicable for determining power when a constant force moves an object at a constant velocity. In order to produce acceleration, power is required, and the force must be applied in the same direction as the velocity, as described in Eq. 3.

### 3. Results and Discussion

In the results and discussion section, we delve into the analysis of data collected through two different methods. The initial method adhered to conventional practices, necessitating manual harvesting within the stipulated timeframe of the project. Concurrently, we utilized cutters equipped with a horizontally moving mechanism driven by a motor. Before quantifying the overall count of harvested chilies, our primary focus was on recording the quantity of chilies gathered through the implementation of our innovative system. This comparative evaluation serves as a significant benchmark for gauging the efficiency and efficacy of our project in contrast to the conventional manual harvesting techniques.

The two distinct harvesting methods, one involving manual labor and the other integrating motor-operated cutters, enable a comprehensive examination of our project's performance. By initially assessing the output of our innovative system before quantifying the overall harvest, we gain valuable insights into the comparative efficiency of our approach against traditional manual harvesting. This analysis is pivotal for refining and optimizing our system for future implementations, potentially revolutionizing the harvesting process for increased productivity and resource utilization.

#### 3.1 Data Pertaining to The Final Product

The data pertaining to the final product of the project was gathered through two distinct methodologies: chilies harvested conventionally and those collected by our project. The conventional method involved manual harvesting within the designated timeframe set for the project, where individuals handpicked the chilies. Simultaneously, the cutters, powered by a motor and operating with a horizontal motion, were employed in the

harvesting process. Before establishing the overall count of chilies processed during the harvest, we meticulously recorded the quantity of chilies procured through the innovative system.

Utilizing two approaches for chili collection, one reliant on conventional manual labor and the other integrating motor-driven cutters, enables a comprehensive assessment of the project's outcomes. The traditional manual harvesting technique, carried out within the project's specified timeframe, provides a benchmark for comparison against the performance of our innovative system. The strategic use of motor-operated cutters adds an element of efficiency to the process. The detailed count of chilies obtained through our system, recorded before determining the total harvest, offers critical insights into the effectiveness and productivity of our project in contrast to conventional methods. This data serves as a foundation for refining and enhancing our approach for future implementations.

**Table 4** Data for the earlier harvesting

Time is taken (min)	Chilies collected by conventional way	Chilies collected by our project
5	75	54
10	180	103
15	263	174

**Table 5** Data for the test long run harvesting

Time is taken (min)	Chilies collected by conventional way	Chilies collected by our project
1 hours	1.75 kg	1.5 kg
2 hours	2.75 kg	3.5 kg
3 hours	4 kg	5.5 kg

Table 4 demonstrates that the results are approximately the same for both traditional methods and the chilies picker tool used in our project, which involves a downward motion to pick up chilies. However, the chilies picker tool proves advantageous for extended periods of picking, as indicated in Table 5, due to human fatigue after picking for several hours. After harvesting, chilies in better condition will retain freshness for a longer duration, resulting in higher market prices.

### 3.2 Comparative Analysis Discussion

In the comparative analysis of chili harvesting, it's observed that the chilies collected through the conventional method surpass those collected by our project. Despite this difference, it's important to note that utilizing our harvesting tool might present some level of misguidance and inconvenience when juxtaposed with the manual hand-picking method, especially considering the process extends over a significant duration. The data reveals that the traditional method outperformed the prototype tool by gathering an additional amount within the designated time frame. Although the efficiency of the prototype tool may not match the speed of the conventional approach, the recorded increase in chilies suggests its potential for more extended periods of use.

Examining the results in terms of speed, the traditional approach proves superior, providing a higher chili count within a shorter timeframe. However, the unique value of our developed harvesting tool lies in its convenience for prolonged chili collection efforts. The tool's efficiency over extended periods positions it as a promising option for more extensive chili harvesting operations. This is particularly noteworthy considering the potential for human fatigue after continuous picking, where the automated tool can offer sustained productivity.

### 4. Conclusion

The objective of this project was to design a prototype for a chili picker that enhances convenience in the chili harvesting process. The chili picker tool has the potential to transform the chili harvesting process by providing a more efficient, productive, and long-term alternative to traditional manual labor. This program offers a realistic option to optimize chili farming operations, boost profitability, and meet the increasing demands of the culinary industry by addressing issues associated with labor-intensive harvesting and minimizing crop damage. The results obtained after running the project indicate that the tool effectively cuts the chilies' pedicles. However, the total number of chilies collected by the tool is lower than those collected using conventional methods. This is primarily due to the tool's motor having a slow rotational speed of 60 rpm and a low torque of 20 Nm. To collect more chilies, the tool's motor should be replaced with one having higher rpm and torque, making it more effective in the harvesting process. Furthermore, the tool requires improvements in connecting the blade and the blade cover to ensure that the blade remains secure during chili collection. Despite these limitations, the project successfully achieved its objective of designing a prototype to assist farmers in harvesting chilies.

## Acknowledgement

The authors would like to thank the Centre for Diploma Studies, University Tun Hussein Onn Malaysia for its support.

## Conflict of Interest

Authors declare that there is no conflict of interests regarding the publication of the paper.

## Author Contribution

This journal requires that all authors take public responsibility for the content of the work submitted for review. The contributions of all authors must be described in the following manner:

*The authors confirm contribution to the paper as follows: **study conception and design, data collection:** Muhammad Adam Sufi Mohd Safri, Muhammad Aiman Haqimie Mohd Jamil, Muhammad Adib Akmal Mohd Hafiz; **analysis and interpretation of results:** Khairulnizam Othman; **draft manuscript preparation:** Muhammad Adam Sufi Mohd Safri. All authors reviewed the results and approved the final version of the manuscript.*

## References

- [1] M. Anem, "Anim Agro Technology: CILI PADI - PROJEK KOMUNITI," Anim Agro Technology, Jul. 31, 2018. <http://animhosnan.blogspot.com/2018/07/cili-padi-projek-komuniti.html>
- [2] A. Sharma and S. Khar, "Current developments in vegetable transplanters in developing countries: a comprehensive review," *International Journal of Vegetable Science*, pp. 1–24, Feb. 2022, doi: <https://doi.org/10.1080/19315260.2022.2046672>.
- [3] K. Othman, A. Hakim, and M. Ilmi, "Future Red Pepper Picker," In *Multidisciplinary Applied Research and Innovation*, vol. 4, no. 2, pp. 192–197, 2023, doi: <https://doi.org/10.30880/mari.2023.04.03.027>.
- [4] H. Entebang, S.-K. Wong, and Z. J. A. Mercer, "Development and Performance of the Pepper Industry in Malaysia: A Critical Review," *International Journal of Business and Society*, vol. 21, no. 3, pp. 1402–1423, Dec. 2020, doi: <https://doi.org/10.33736/ijbs.3361.2020>.
- [5] M. Anem, "Anim Agro Technology: Microbes and Biodiversity," *Anim Agro Technology*, May 18, 2010. <http://animhosnan.blogspot.com/2010/05/microbes-and-biodiversity.html>
- [6] B. Kaur, "Marketing Margins and Market Efficiency for Vegetables in Malaysia," *Journal of Agribusiness Marketing*, vol. 8, pp. 60–70, 2017, Available: <https://www.fama.gov.my/documents/20143/555952/MARKETING+MARGINS+AND+MARKET+EFFICIENCY+FOR+VEGETABLES+IN+MALAYSIA+%282%29.pdf/5d9bb0ed-807f-8e23-e45f-26978a523a6c>