

## Real-Time Monitoring for Smart Logistics

Muhammad Adham Mokhtar<sup>1</sup>, Aizan Ubin<sup>1\*</sup>

<sup>1</sup>Department of Electronic Engineering, Faculty of Electrical and Electronic Engineering,  
Universiti Tun Hussein Onn Malaysia, Batu Pahat, 86400, MALAYSIA

\*Corresponding Author Designation

DOI: <https://doi.org/10.30880/eeee.2022.03.02.098>

Received 29 June 2022; Accepted 3 October 2022; Available online 30 October 2022

**Abstract:** Unexpected occurrences like temperature swings and humidity changes have the potential to devalue the value of products being carried. Unwanted occurrences must be avoided, and flaws in the delivery process must be addressed. The Internet of Things (IoT) allows us to determine when, where, and how certain abnormalities in the supply process happened. Because IoT can be integrated into traditional supply chains to track, trace, and monitor vehicle movement, it may be able to solve some transportation issues. This project is now presenting the design and implementation of real-time data monitoring for smart logistics. The goal of this project is to sense temperature, humidity, and GPS data and send the data via the Favoriot Platform. Furthermore, this system allows these data to be sent to the transportation firm as a notification for an alert system. The scope of the research is to sense the range of temperature (-20°C - 10°C) and level of humidity (60% - 100%) and current location in transportation. The methodology was developed using selected hardware and software such as DHT22, GPS module, Hibiscus Sense ESP32, Arduino IDE, Wi-Fi connectivity and Favoriot Platform. Based on the result, the real-time data have been successfully recorded and compared with the simulated data to make sure that the results designed for this project are correct and by the theory.

**Keywords:** Favoriot Platform, Smart Logistics System, Internet Of Things (Iot)

### 1. Introduction

The Internet of Things (IoT) represents the next step towards the digitization of our society and economy [1], where objects are interconnected through communication networks and exchange information about their status and/or the surrounding environment. Modern logistics includes a lot of characteristics, such as systematic industry, a combination of logistics and information technology, technology modernization, integration of supply, integration services, full service and network, and architecture of logistics system [2]-[3].

#### 1.1 Smart Logistics

IoT-based smart monitoring application for tracking the circumstances under which commodities are carried and kept in this study. This application should include vehicle fleet tracking, goods monitoring and control, location-based services, and other services to improve the performance, safety, and reliability of the transport process [4].

Smart logistics, also known as “intelligent logistics” or “logistics 4.0”, comes from the concept of the “intelligent logistics system” proposed by IBM. The concept has no unified definition, and it is generally recognized as a more intelligent and efficient way to plan, manage, and control logistic activities with intelligent technologies [5]. As shown in Figure 1, technologies, such as the Internet of Things (IoT), big data analytics, and AI, applied in smart logistics differentiate from that used in traditional logistics with four characteristics. We focus on various IoT applications in logistics and transportation in this study, and we describe an IoT-based smart monitoring application for monitoring the circumstances under which items are carried [6].

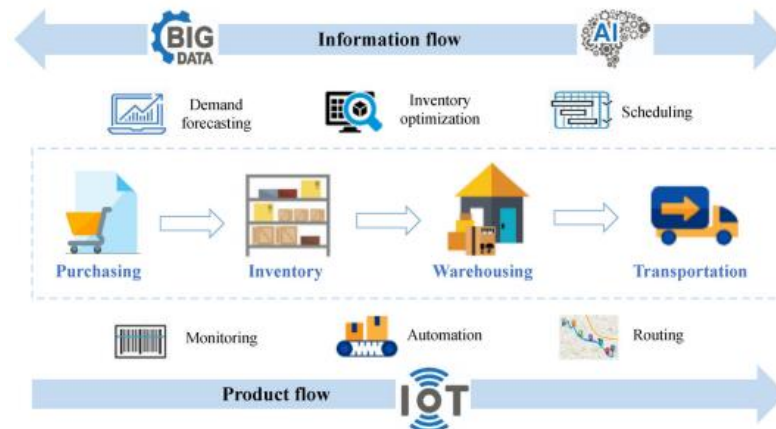

**Figure 1: Smart Logistics System**

## 1.2 Cold Chain Logistics

The phrase "cold chain" refers to the apparatus and procedures that are used to maintain the temperature at which the items, such as food, vaccines, blood, and tissues, among other things, should remain stable to be kept. This temperature is essential for the safety of the product. Any fluctuation in temperature has the potential to compromise the items' characteristics and qualities. Because of the reasons indicated above, it is essential to always keep a close eye on the temperature and record its readings so that it can be tracked. In addition, if products need to be transported, the position coordinates should be taken into consideration as well. This is because there is a possibility that logistics personnel will make mistakes, which could result in the product being delivered via routes that are not the most efficient and an increase in the amount of time it takes to transport the product [7]-[10].

The quality of the Cold Chain Logistics (CCL) is determined by several different factories, and one of those factories is the transportation management system. The act of moving things, including people, animals, and objects, from one place to another is known as transportation. There are many ways to travel, including via air, train, road, water, pipeline, cable, and space. The industry may be broken down into three categories: operations, cars, and infrastructure. It is vital for the growth of civilizations for people to be able to trade with one another, hence transport plays a critical role in making this possible. Even while most forms of transportation contribute to pollution in the air and take up a significant amount of land, they serve an essential role in the expansion of economies and the process of globalization. Even though it receives substantial funding from the government, efficient transportation planning is still necessary to keep traffic moving and limit urban development [8].

In this study, we made use of the Vehicle Routing Problem (VRP), which is a method that is used by many individuals while researching transportation. According to the definition of the VRP,  $m$  trucks that are originally based at a depot have the responsibility of delivering discrete amounts of commodities to  $n$  different clients. A VRP challenge involves determining the most efficient path that should be taken by a fleet of vehicles to satisfy a community of end customers. The whole expense of transportation is something that must be cut down as much as possible. The answer to the traditional VRP issue is a collection of routes that fulfills the condition that each of the customers gets serviced exactly once and that all the routes begin and terminate in the same location, which is the depot. It is possible to bring down the overall cost of transportation by shortening the total distance traveled and cutting down on the number of vehicles that are necessary [9].

## 2. Methodology

This section explains the block diagram of this project. It also describes the flowchart of project development and project design utilizing selected hardware and software. The schematic diagram will be briefly explained, and the specification of the hardware development will be stated here. Finally, the circuit design and final prototype of this project will be presented, and the outcome is given in the next section.

### 2.1 Block Diagram of the Project

Based on the research that has been done, the outcome of this project is the real-time monitoring of smart logistics based on the Internet of Things. Figure 2 shows the block diagram of the project transportation in logistics that monitor based on temperature, humidity, and GPS and real-time data analysis using Favoriot software. When the transportation starts departing, the temperature, humidity, and GPS will start measuring and data will display every second and monitor through the Favoriot Platform. By understanding this project, the Internet of Things in logistics will be easily monitored and gives an alert or notification if anything happens on transportation.

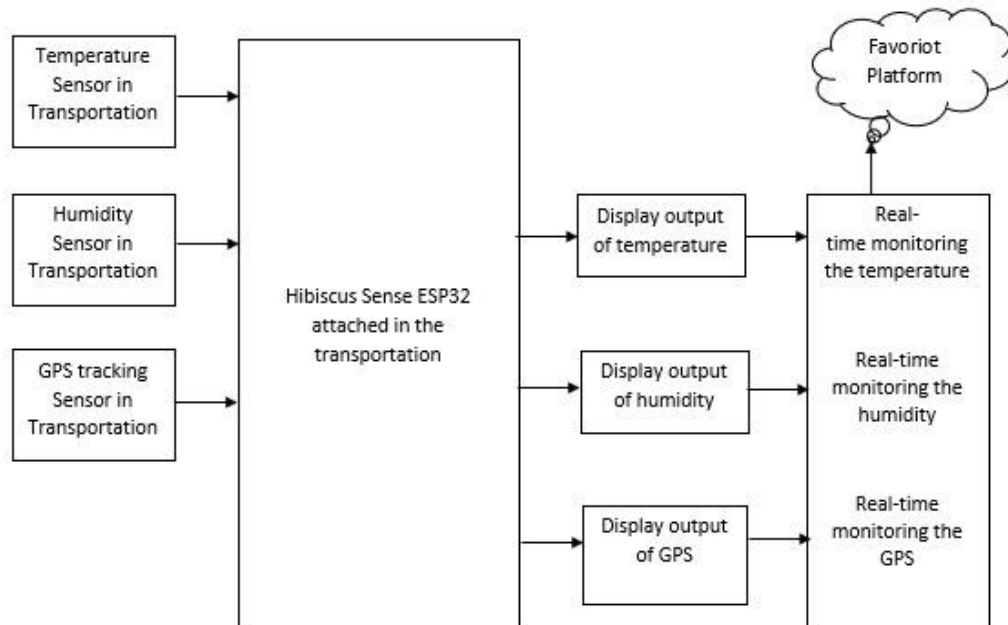

**Figure 2: Block diagram of Real-Time Monitoring of Smart Logistics**

### 2.2 Flowchart Process of the Project

The main aim of this project for logistics is to monitor the temperature and humidity in logistics based on the Internet of Things. This project may help the user to monitor the temperature, humidity, and GPS tracking on logistics.

Figure 3 shows the flowchart of the project. The development process should start with the transportation that will start departing, which is the project will run begin after the transport start depart. Next, the project progress is to run the measuring the parameter of temperature at temperature sensor and will sense the item of temperatures such as frozen food, fresh vegetables, fruit, and item with a sensitive variation of temperature. If the design error or parameters error occurs, the process for this sensor must sense the temperature until can read the parameter. Furthermore, the project progress is to run the measuring the parameter of humidity at humidity sensor and will sense the humidity in transport. If a parameters error occurs, the process for this sensor needs to sense back again the humidity in transport. Last, the project progress is to measure the parameter of GPS in transport. The GPS will detect the current location of transport and the data of the GPS will display and monitor through the Favoriot Platform.

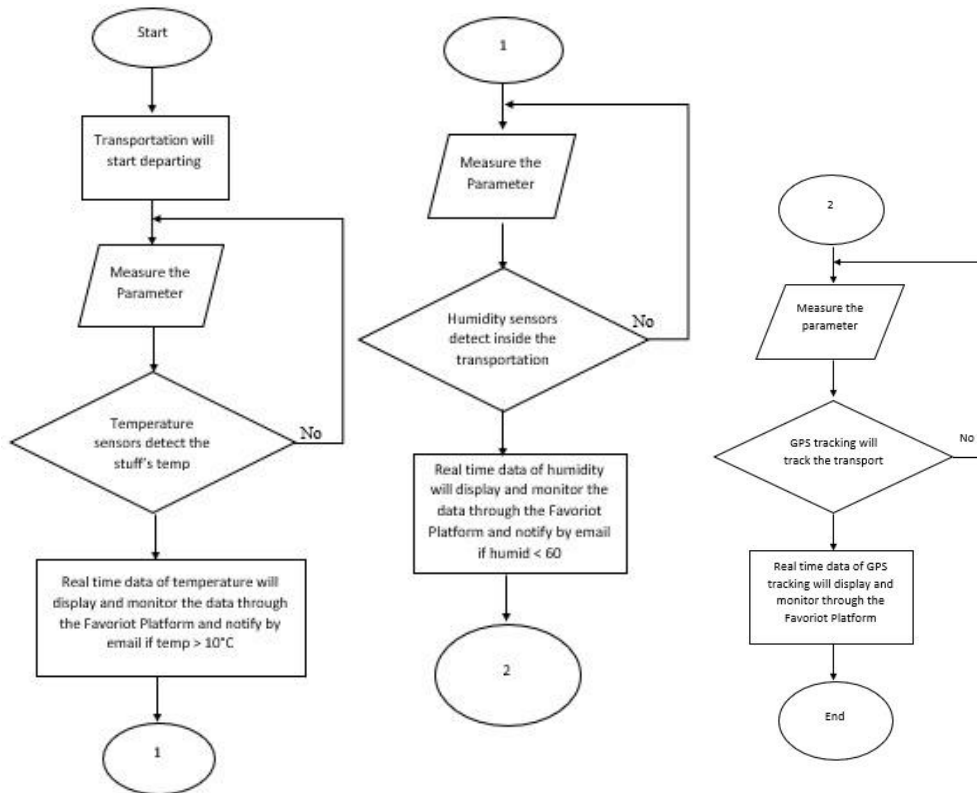
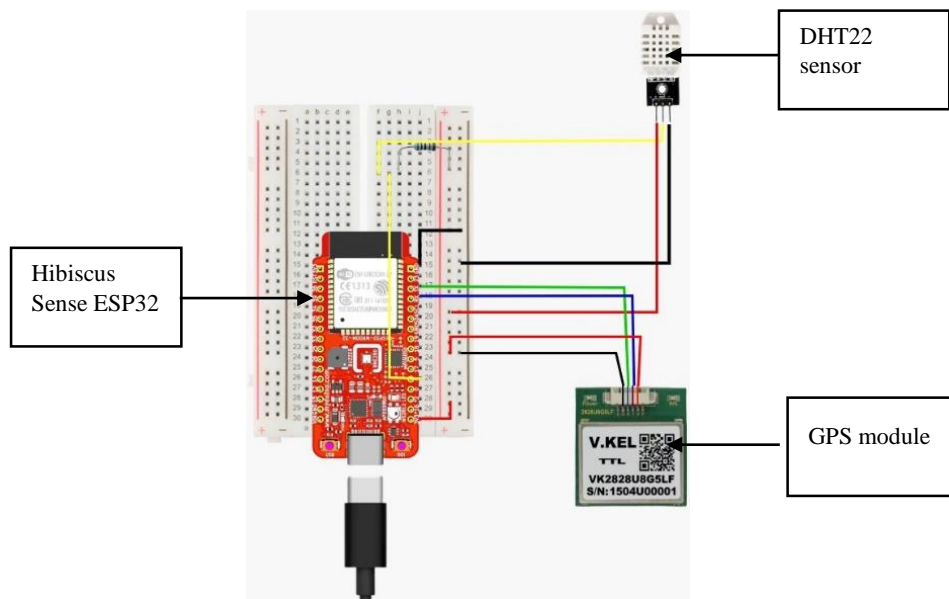

Figure 3: Flowchart of Real-time monitoring of the temperature, humidity, and GPS

### 2.3 Schematic Circuit of the proposed system

Based on the research that has been done, the proposed outcome of this project is that real-time monitoring in smart logistics based on the Internet of Things. Figure 4 shows the schematic circuit of the proposed system of real-time monitoring for smart logistics. The expected performance specification at the end of the project is the transportation in logistics will monitor based on temperature, and humidity by DHT22 sensor and GPS by GPS module and real-time data analysis using Favoriot software. When the transportation starts departing, the temperature, humidity, and GPS will start measuring and data will display every second and monitor through the Favoriot Platform. By understanding this project, the Internet of Things in logistics will be easily monitored and gives alert or notification if anything happens on transportation.



#### Figure 4: Schematic Circuit of the proposed system

#### 2.4 Circuit Design and Final Prototype of Project

This section discusses the connection of the sensor, which is DHT22, and the main component of the project is Hibiscus Sense ESP32. Based on Figure 5, the function of DHT22 is utilized to sense temperature and humidity while the GPS module is used to sense the current location of latitude and longitude. The system consists of a Hibiscus Sense ESP32 which is going to be the center of the system. Favoriot Platform is used as the medium for the system to communicate wirelessly over the internet. Figure 6 shows the final prototype of the project, which consists of a frozen compartment as a logistics, and the project will be tested on the frozen compartment.

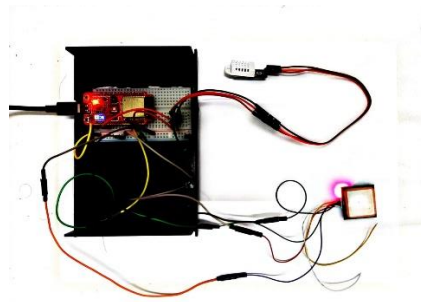

Figure 5: Circuit Design of Project



Figure 6: Final Prototype of Project

### 3. Results and Discussion

This section briefly explains the outcome of the project. It covered the simulation results of hardware and software. The simulation of Arduino Integrated Development Environment (IDE) results of the project are illustrated and evaluated to accomplish the hardware and software operation. The desired functionality of the Favoriot Platform, as well as real-time monitoring for smart logistics, will be covered in two separate sections, namely the “Favoriot Data Streams” and the “Favoriot Dashboard” which defines monitoring the data by the Internet of Things.

#### 3.1 Serial Monitor Arduino Integrated Development Environment (IDE)

The Arduino board was designed to download the Arduino software's code (IDE). The Arduino IDE enabled the DHT22 sensor to sense temperature and humidity and the GPS module sensor to sense a current location in transportation, ensuring the program ran properly within the project scope. The Hibiscus Sense ESP32 only connects to the Arduino IDE, which connects to the Favoriot Platform to display the DHT22 and GPS module sensor data. After uploading the code to Hibiscus Sense ESP32, the serial monitor of the Arduino software (IDE) displays the DHT22 sensor value and the GPS module sensor value. Figure 7 shows the serial monitor display DHT22 sensor value and GPS module sensor value.

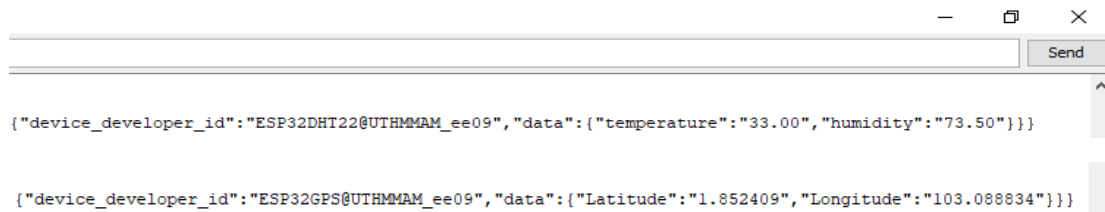

Figure 7: The serial monitor displays the DHT22 sensor and GPS module sensor

### 3.1.1 Favoriot Data Streams

The smart logistics can be added as a new database operation using Favoriot Platform, which stores information about temperature, humidity, latitude, longitude, and current date and time. Figure 8 shows Data Streams obtained from the Favoriot Platform. All the streaming will display the value of temperature, humidity, latitude, and longitude based on the simulation test.

Select	Device Developer ID	Data	Uploaded
<input type="checkbox"/>	ESP32DHT22@UTHMMAM_ee09	"humidity": "87.40", "temperature": "3.10"	6/21/2022, 5:36:35 PM
<input type="checkbox"/>	ESP32DHT22@UTHMMAM_ee09	"humidity": "87.40", "temperature": "3.10"	6/21/2022, 5:28:34 PM
<input type="checkbox"/>	ESP32DHT22@UTHMMAM_ee09	"humidity": "87.40", "temperature": "3.10"	6/21/2022, 5:28:24 PM

Select	Device Developer ID	Data	Uploaded
<input type="checkbox"/>	ESP32GPS@UTHMMAM_ee09	"Latitude": "1.852409", "Longitude": "103.088834"	6/5/2022, 4:04:08 PM
<input type="checkbox"/>	ESP32GPS@UTHMMAM_ee09	"Latitude": "1.852409", "Longitude": "103.088834"	6/5/2022, 4:04:02 PM
<input type="checkbox"/>	ESP32GPS@UTHMMAM_ee09	"Latitude": "1.852409", "Longitude": "103.088834"	6/5/2022, 4:03:57 PM

Figure 8: Temperature, Humidity, Latitude and Longitude value in Favoriot Data Streams

### 3.1.3 Favoriot Dashboard

The system was designed to collect data from the sensors and store it in a central microcontroller before sending it to an Internet of Things platform (IoT). The Internet of Things platform can store, analyse, and preview data for the user through a private or public web interface. Figure 9 shows the resulting graph by using the Dashboard Favoriot Platform.



Figure 9: The result of temperature, humidity, latitude, and longitude via Dashboard Favoriot Platform



### 3.2 Discussion

This section discussed the result of temperature and humidity that appear in Data Streams and Dashboard Favoriot Platform. Also, the result of positioning location appears in Data Streams and Dashboard Favoriot Platform. The results were analyzed, and it can conclude that the simulation result is achieved with the theoretical method.

#### 3.2.1 Analyze Temperature and Humidity

From the observation, the temperature in the frozen compartment needs at least below 10°C. Figure 10 shows the temperature is really maintaining and going up slowly, but it is enough that the temperature can achieve below 10°C while the simulation test is running for 5 hours and 30 minutes. It could be achieved below 0°C if this test is used at frozen transportation. So, this simulation test can be achieving the objective because can be monitored in real-time and analyze real-time data based on the Internet of Things.

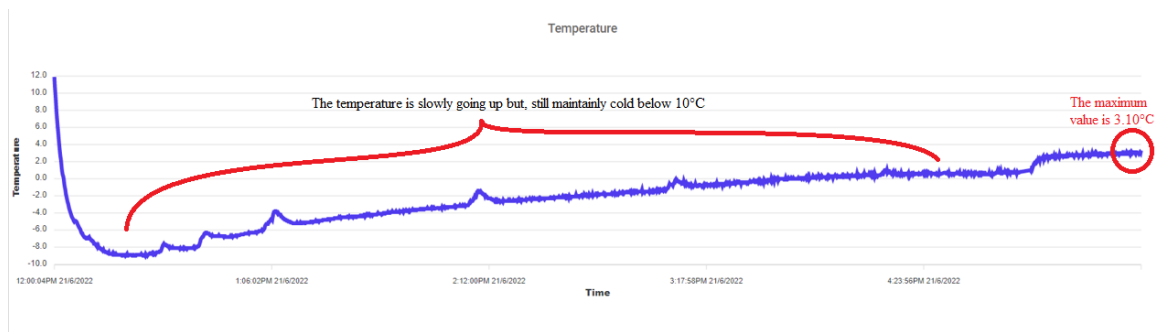

**Figure 10: Analyze real-time data on temperature**

Figure 11 shows the humidity is maintained at 60% - 100% even though the early humidity level starts from 55%. This simulation test of humidity achieves the objectives because it can be monitored in real-time and analyze real-time data analysis based on the Internet of Things.

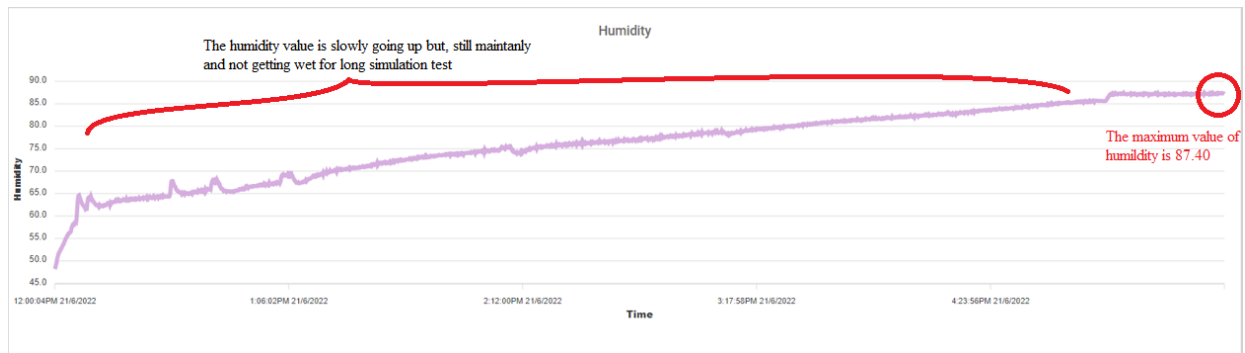

**Figure 11: Analyze real-time data on humidity**

Table 1 shows the real-time data of temperature and humidity from 6/13/2022 - 3:15:21 PM till 6/13/2022 - 3:25:33 PM.

**Table 1: Real-time data of temperature and humidity 6/21/2022 - 12:25:47 PM till 6/21/2022 - 12:26:57 PM**

Device_Developer_Id	Humidity	Temperature	Stream_Created_At	Local_Timestamp
ESP32DHT22@UTHMMAM_ee09	64.3	-9	2022-06-21T04:26:57.953Z	6/21/2022 - 12:26:57 PM
ESP32DHT22@UTHMMAM_ee09	64.1	-8.9	2022-06-21T04:26:47.898Z	6/21/2022 - 12:26:47 PM
ESP32DHT22@UTHMMAM_ee09	64.1	-8.9	2022-06-21T04:26:37.884Z	6/21/2022 - 12:26:37 PM
ESP32DHT22@UTHMMAM_ee09	63.9	-8.8	2022-06-21T04:26:27.862Z	6/21/2022 - 12:26:27 PM

ESP32DHT22@UTHMMAM_ee09	64.1	-8.9	2022-06-21T04:26:17.845Z	6/21/2022 - 12:26:17 PM
ESP32DHT22@UTHMMAM_ee09	63.9	-8.9	2022-06-21T04:26:07.808Z	6/21/2022 - 12:26:07 PM
ESP32DHT22@UTHMMAM_ee09	64.2	-8.9	2022-06-21T04:25:57.840Z	6/21/2022 - 12:25:57 PM
ESP32DHT22@UTHMMAM_ee09	64	-8.9	2022-06-21T04:25:47.774Z	6/21/2022 - 12:25:47 PM

### 3.2.2 Analyze on Global Positioning System (GPS)

The location of transport can be monitored based on the current location of the GPS module. The GPS module has tiny processors and antennas that receive data directly from satellites through specific RF frequencies of the device. It will receive timestamps from each visible satellite. Figure 12 shows the current location of the transport which locate around Parit Haji Rais with the reading of latitude 1.852409 and longitude 103.088834. The monitoring process can be done through the Favoriot Platform. Thus, the objective can be achieved using this simulation test as it can monitor and analyze the real-time data based on the IoT.

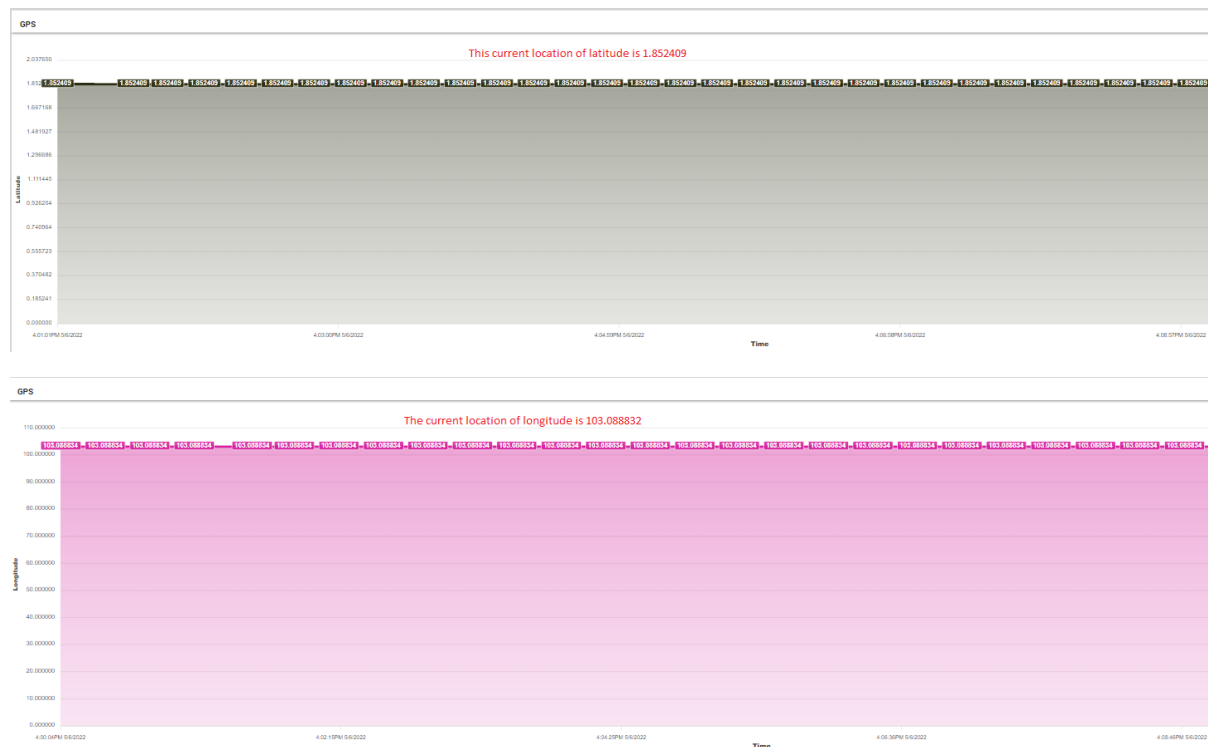

**Figure 12: Analyze real-time data of location latitude and longitude**

All the data that stream at Favoriot Platform will display. Table 2 shows the real-time data of latitude and longitude from 6/5/2022 - 4:12:55 PM till 6/5/2022 - 4:05:51 PM.



**Table 2: Real-time data of latitude and longitude 6/5/2022 - 4:08:11 PM till 6/5/2022 - 4:08:52 PM**

Device_Developer_Id	Latitude	Longitude	Stream_Created_At	Local_Timestamp
ESP32GPS@UTHMMAM_ee09	1.852409	103.0888	2022-06-05T08:08:52.752Z	6/5/2022 - 4:08:52 PM
ESP32GPS@UTHMMAM_ee09	1.852409	103.0888	2022-06-05T08:08:47.552Z	6/5/2022 - 4:08:47 PM
ESP32GPS@UTHMMAM_ee09	1.852409	103.0888	2022-06-05T08:08:42.363Z	6/5/2022 - 4:08:42 PM
ESP32GPS@UTHMMAM_ee09	1.852409	103.0888	2022-06-05T08:08:37.197Z	6/5/2022 - 4:08:37 PM
ESP32GPS@UTHMMAM_ee09	1.852409	103.0888	2022-06-05T08:08:32.005Z	6/5/2022 - 4:08:32 PM
ESP32GPS@UTHMMAM_ee09	1.852409	103.0888	2022-06-05T08:08:26.824Z	6/5/2022 - 4:08:26 PM
ESP32GPS@UTHMMAM_ee09	1.852409	103.0888	2022-06-05T08:08:21.666Z	6/5/2022 - 4:08:21 PM
ESP32GPS@UTHMMAM_ee09	1.852409	103.0888	2022-06-05T08:08:16.520Z	6/5/2022 - 4:08:16 PM
ESP32GPS@UTHMMAM_ee09	1.852409	103.0888	2022-06-05T08:08:11.308Z	6/5/2022 - 4:08:11 PM

From the observation, this data can monitor the latitude and longitude through the Favoriot Platform and Google Maps as shown in Figure 13. This simulation test of GPS achieves the objectives because can be monitored in real-time and analyses real-time data analysis in logistics based on the Internet of Things.

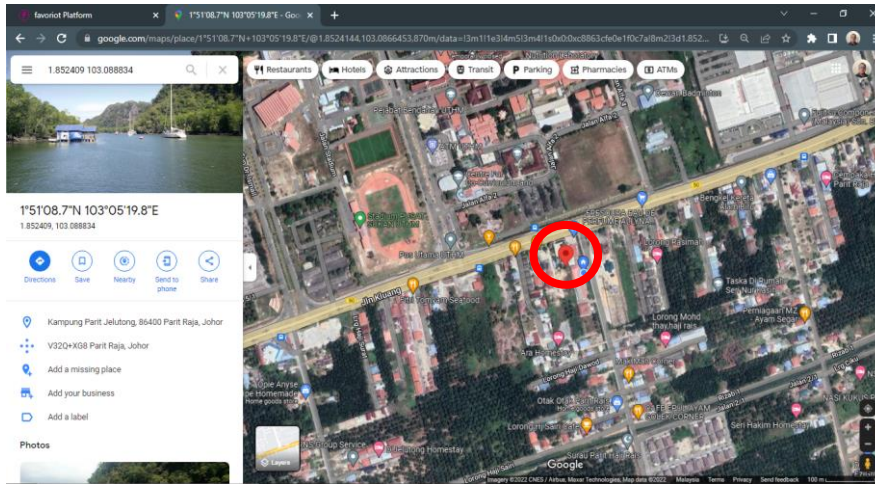

**Figure 13: Current location locates at Parit Haji Rais on Google Maps**

**4. Conclusion**

In the process of completing this project, the simulations and experimental hardware for monitoring temperature, humidity, and GPS-based Internet of Things were presented. The simulated circuit design and code design produced correct findings as an outcome. However, it needs to be enhanced to take into transportation logistics and the Internet of Things (IoT) based on real-time monitoring. The findings show the output of temperature, humidity, and GPS displayed in the Favoriot Platform. At the end of this study, the objectives of this project are achieved and analyzed with the result obtained. This project also gives more understanding to the theory of the Internet of Things. This project has been achieved with the support of several software such as Favoriot Platform and Arduino. The data have been recorded and compared with the simulation to make sure that the result designed for this project is correct and in accordance with the theory.

**Acknowledgement**

The authors would like to thank the Faculty of Electrical and Electronic Engineering (FKEE), Universiti Tun Hussein Onn Malaysia (UTHM) for its support.

## References

- [1] Rose K., Eldridge S., Chapin L., “The Internet of Things (IoT): An Overview – Understanding the Issues and Challenges of a More Connected World, Internet Society.”, 2015, pp. 1-50.
- [2] Chuanyu S., “Analysis on the Interaction of both Computer Network and Modern Logistics.” E-Business Journal, Sept 2009, pp. 44-45.
- [3] Shaoai Wu, “Analysis on the relationship between Modern Logistics and Multimodal Transport.” *New West* (10), 2009, p. 37.
- [4] Deljanin A, Colakovic A, Muharemovic E., “Rationalization of Transport of Postal Shipment using GPS / RFID Technology in Bosnia and Herzegovina.” *Modern Traffic*, Feb 2014 ,34(1-2), pp. 26-31.
- [5] Zhang G, “Large data and intelligent logistics.” *Journal of Transportation Systems Engineering and Information Technology*, Feb 2015, 15(1): pp. 2–10, 233.
- [6] Zaritzky, N.E., “Mathematical simulation of the thermal behavior of frozen meat during its storage and distribution.” *Journal Food Process Engineering* 6.1, Jan 1982, pp. 15-36.
- [7] Li F, Chen Z., “Brief analysis of application of RFID in pharmaceutical cold-chain temperature monitoring system.” In: *Proceedings 2011 International Conference on transportation, mechanical, and electrical engineering (TMEE)*, Dec 2011, pp. 2418–2420.
- [8] Esper, Terry L, Lisa R. Williams, “The value of collaborative transportation management (CTM): it’s relationship to CPFR and information technology.” *Transportation Journal*, Jul 2003, pp. 55–65.
- [9] Caric, T. and Glod, H., “Vehicle Routing Problem.” In-the, University Library Rijeka under no. 111225011, 2008.
- [10] Palacio MG, Palacio LG, Montealegre JJ, Pabo´n HJ, del Risco MA, Rolda´n D, Salgarriaga S, Va´squez P, Herna´ndez S, Marti´nez C. “A novel ubiquitous system to monitor medicinal cold chains in transportation.” In *2017 12th Iberian Conference on information systems and technologies (CISTI)*, June 2017, pp. 1–6.