

## Development of Test Chamber for Gas Insulation Testing and Measurement

Rizwan Ahmed<sup>1</sup>, Rahisham Abd Rahman<sup>1\*</sup>, Muhd Hakimi Al Iqbal Shahri<sup>1</sup>

<sup>1</sup>Faculty of Electrical and Electronics Engineering,  
Universiti Tun Hussein Onn Malaysia, 86400, Batu Pahat, MALAYSIA

\*Corresponding Author Designation

DOI: <https://doi.org/10.30880/eeee.2022.03.01.064>  
Received 23 January 2022; Accepted 30 May 2022; Available online 30 June 2022

**Abstract:** This paper is concerned with high-voltage components like circuit breakers, disconnect, and grounding switches in a metal pipe and insulates them with sulfur hexafluoride  $SF_6$  and considering  $SF_6$  gas is 25,000 times more potent than  $CO_2$  and takes 3200 years to degrade in the atmosphere, it is becoming increasingly important to recycle it. Further analysis of  $C_4F_7N$  (some friendly gases, which have the potential to replace  $SF_6$ ) is conducted trying to point out the further research direction and the insulation properties of  $C_4F_7N$  with a buffer gas like  $CO_2$  are still unidentified. This study will explore the materials, parameters, and components used in the  $C_4F_7N$  test chamber. Second, the vessel structure must be able to withstand high pressure, and the materials must be industrial grade. Thirdly, the test rig can test pressures up to 5 bars (abs). Thus, this study designed and developed a  $C_4F_7N$  gas test chamber system to measure gas insulation. The testing of High-Voltage Alternating Current (HVAC), High Voltage Direct Current (HVDC), and Generation Impulse Voltages were used to test the endurance and effectiveness of the chamber. Overall, these tests show that the chamber can withstand voltages of 67.6kV and higher. The linear actuator is capable and reliable, and it's quick and easy to control with a DPDT switch instead of opening the chamber cover. The percentage of leakage was very low, making it suitable for further experiments or testing even higher breakdowns.

**Keywords:** Test Chamber, Gas Insulation Testing,  $C_4F_7N$

### 1. Introduction

In general, gas insulation is defined as the investigation of the fundamental physical and chemical characteristics of insulating gases in order to suggest a number of ecofriendly insulating gases as viable replacements for sulphur hexafluoride ( $SF_6$ ). Trifluoroiodomethane ( $CF_3I$ ), octafluorocyclobutane ( $C_4F_8$ ), and heptafluorobutyronitrile ( $C_4F_7N$ ) are mixed with buffer gases such as nitrogen ( $N_2$ ) and

carbon dioxide ( $CO_2$ ). The mixture ratio is maintained as 90% buffer gas and 10% main gas. The gas composition is tested under 5-20 mm sphere plane electrode gaps in a non-uniform electric field under lightning impulse voltages with positive and negative polarities. Eco-friendly gas insulation is expected to grow in popularity. Further study on  $C_4F_8$ ,  $CF_3I$ , and  $C_4F_7N$  (some benign gases with the ability to replace SF6) is being carried out in order to point up future research directions.

The gas chamber is designed to safely test and analyze the dielectric properties of test gas  $C_4F_7N$ . The testing method is carried out to verify the technical data and the overall safety of the gas vessel installation during the course of its lifetime [1,2]. Following that, technological advancements in manufacturing techniques and new materials for metallic elements and insulating portions will lead to easier technical solutions for pressure vessel design. This will save material and production costs while also increasing dependability due to its simplicity. Whenever a structure is simplified, the equipment's lifespan is often extended and maintenance is reduced. Simpler design typically involves the use of new materials or production techniques to reduce manufacturing costs while maintaining functionality and dependability [3,4]. Hence, this project major goal is to create a test chamber system for  $C_4F_7N$  gas insulation testing and measurement.

## 2. Structure of the design

The vessel is comprised of a cylinder made of Plexiglass between the top and bottom flanges, which are connected to high voltage (HV) and ground potential, respectively, by means of electrical connections. This cover has an inlet and outlet valve, and a vacuum and pressure gauge. Both plates can be removed from the vessel at the top and bottom to clean and replace the electrodes. The transparent body is required to view the entire process in the vessel while testing the  $C_4F_7N$  gas mixture, along with adjusting and verifying the distance between the high voltage and ground electrodes. Figure 1 represents the CAD drawing of the pressure vessel. The vessel is 60 cm in height with a width of 12 cm, and its volume is approximately 67.85 liters.

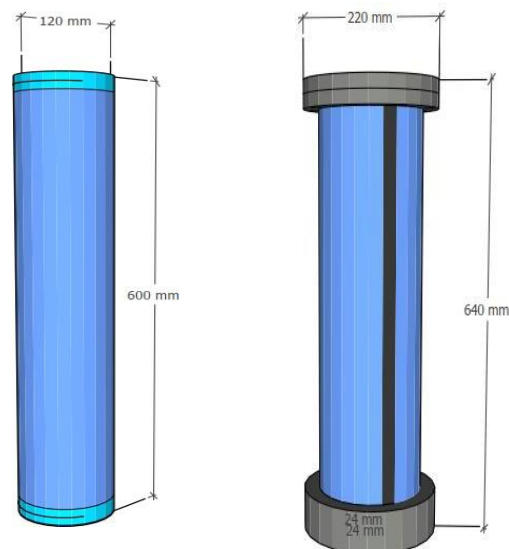

**Figure 1: Pressure vessel and Structure**

Figure 2 shows the bottom view of the test chamber. It includes a total of 5 small holes in the bottom part which are separated by 24 mm. the holes are designed in various sizes for assemblies like Guages, linear actuators, gas inlet pumping, gas outlet, and humidity sensors.

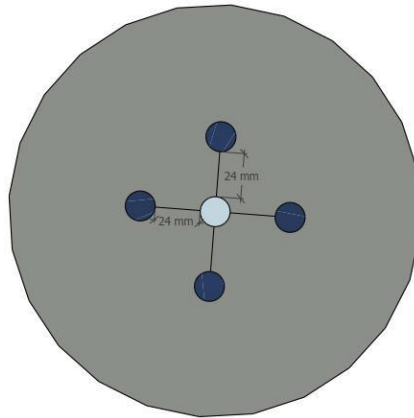

**Figure 2: Bottom view of the pressure vessel**

## 2.1 Fitting and Assemblies

Based on the vessel there are a total of 5 holes of various sizes to house the various assemblies and fittings for measurement purposes. All the necessary equipment fittings have been explained in this section.

### A. Gauges

In the experimental setup, two types of gauges are utilized to measure pressures less than 1 bar (abs) and greater than 1 bar. A -1 to +1 bar gauge is used to ensure continuity between the pressurized state and vacuum state, which improves the accuracy of pressure measurements. The specified gauges have a diameter of 100 mm and a bottom entrance of 16.7 mm.

### B. Hose, Valve and Hose Tails

To prevent the hoses from collapsing under vacuum, a high-durability hose is necessary to link gas cylinders to the vessel. A good hose will have no gas leaks along its length. Hence, the 3/8" Toyo vacuum hose, 3/8" ball valves, and 3/8" hose tails. The hose tails must be used to join the hose to ball valves to properly lock the pressurized state (vacuum or positive pressure).

## 2.2 Electrodes

There are 8 electrode geometries, including plane-plane, sphere plane, and rod plane electrode systems. Rod electrode has a 45° angle and a 0.5 mm radius tip. There are 6 mm, 12 mm, 24 mm, and 48 mm electrodes. Both a 25 mm sphere electrode and a 45 mm plane electrode are available. With an M10 rod, each electrode is threaded into the bushing.

The electrodes are brass, a copper-zinc alloy (Zn). For free-machining properties, up to 3% lead (Pb) is often added. Brass is non-sparking. This is vital in hazardous environments to avoid sparks.

## 2.3 Linear Actuator

In between high voltage and ground electrodes, a variable gap length arrangement is preferred. In addition, various test parameters like applied pressure, gas mixture, and electrode design can be maintained. When the vessel is under pressure, the system must be mounted in a pressurized vessel and operated from the outside (to vary the gap without removing gas). In that instance, a linear actuator can fix the issue.

### A. Linear Actuator Unit

Between high voltage and ground electrodes, a variable gap length arrangement is preferable. Various factors, including mixture, pressure, and electrode geometry, can also be preserved. When the vessel is under pressure, the system must be installed and managed from outside (for varying gaps without removing gas). In that instance, a linear actuator can fix the issue.

### B. Linear Actuator Controller

A controller constituting a feedback loop is necessary before any tests to guarantee that the actuator advances to the ground electrode as well as stops at the precise gap length. As a result, a Phidgets Controller is utilized in a linear actuator to control its position and velocity. A USB port on a laptop or PC is used to power the controller.

### 2.4 Compressing Seal Fitting

In the holes as can be seen in Figure 3, a compression seal fitting often referred to as a sealing gland, is required. This is used to seal wires that exit the vessel under pressure. Due to the pressure difference between the wires' ends, a sealing gland prohibits leakage of gas along the wires while simultaneously holding them steady.

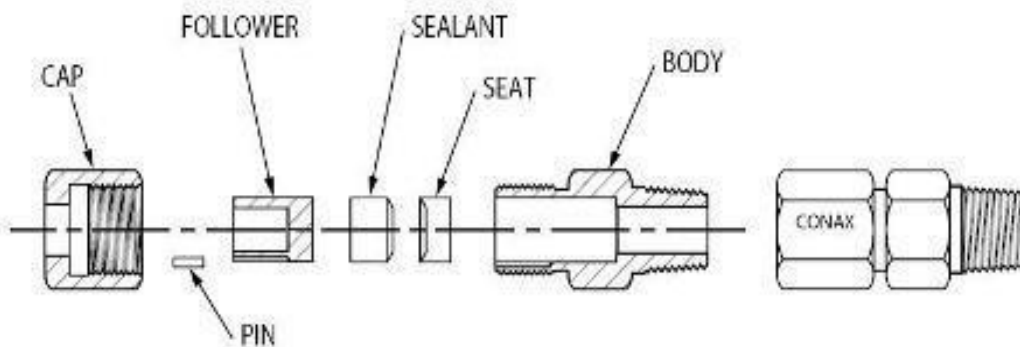

Figure 3: Compression seal fitting

### 2.5 Generation and measurement of AC Voltage

The 220V/100kV Test Transformer is used to make high voltage AC in the lab (HV9105) as shown in Figure 4. This is fed and controlled by the Control Desk. The Control Desk The high voltage experiments must be done in a special area that is surrounded by metal barriers. It comes with control desks with power supplies, safety circuits, and measuring instruments as standard [5]-[9]. Each desk has an instrument that can measure the primary voltage of a transformer and an AC peak voltmeter (HV9150) that can measure the voltage of AC.

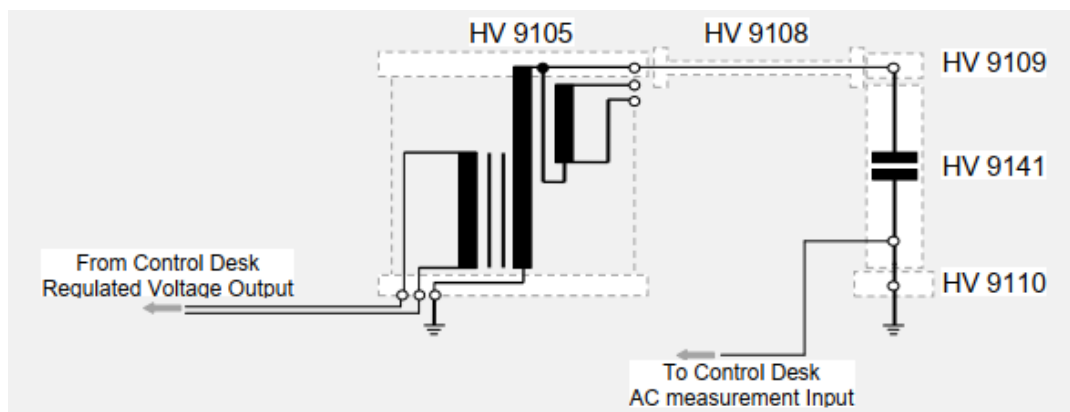
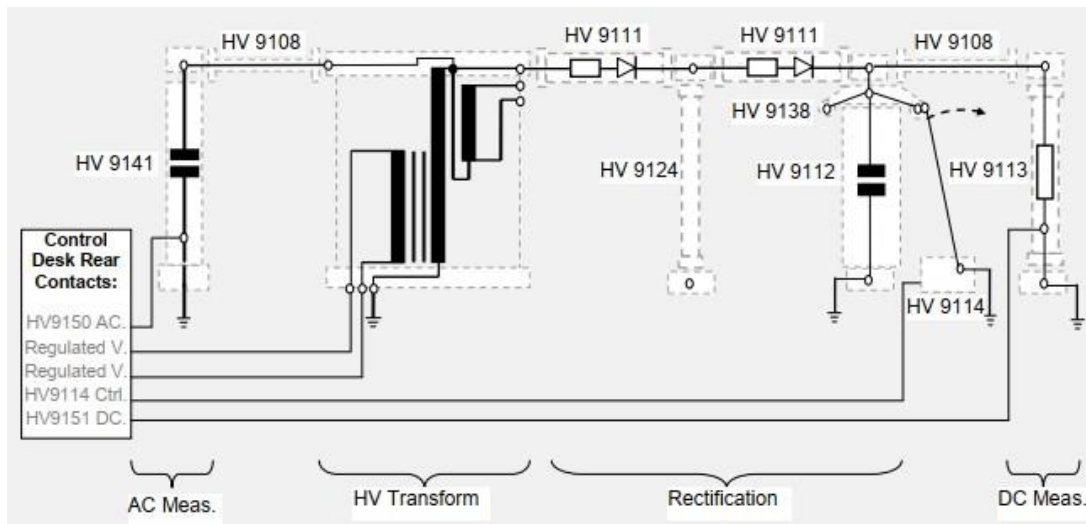

Figure 4: Circuit for AC Voltage Measurement via Control Desk Instrumentation

### 2.6 Generation and Measurement of Direct Current

Measurement of high voltage DC, like measuring low voltages, voltages are usually done by extending the meter range with large resistance. When the meter is a full scale, the net current cannot be more than one or two microamperes. High voltages (1,000 kV or more) cause problems like power dissipation, leakage current, limited voltage stress per unit length, temperature changes in resistance, and so on. An electrostatic voltmeter and resistance potential splitter can be more precise in this case, but not always. But potential dividers face the same issues. The current source is drained by a potential divider and a series of resistance meters. These high-impedance meters do not strain the source. Since they're not connected directly to the high voltage terminal, they are entirely insulated from the source voltage (high voltage). Because they are not directly linked to the high voltage terminal, they are safer. When a spark gap, like a sphere gap, is used, it gives an accurate peak voltage reading. These are very easy to make and don't need any special tools. However, factors such as humidity, temperature, and the presence of grounding objects influence the measurement. This is because the existence of grounding objects affects the electric field strength in the gap [10]. Figure 5 shows the direct voltage measurement setup diagram.



**Figure 5: Direct Voltage Measurement Setup Diagram**

### 2.7 Generation and measurement of impulse voltage

The SGSA 400-20 Haefely impulse generator, as well as a charging rectifier LGR 100-20, are primary pieces of apparatus being used in the generation of impulse voltages in the current research. Four stages of 100kV each stage are employed in the non-inverting impulse generator, giving a total output voltage of 400kV. A maximum output voltage of 400 kV is possible with the Marx generator circuit, which can provide 100 kV at each stage. Figure 6 depicts a schematic diagram of the generator electrical.

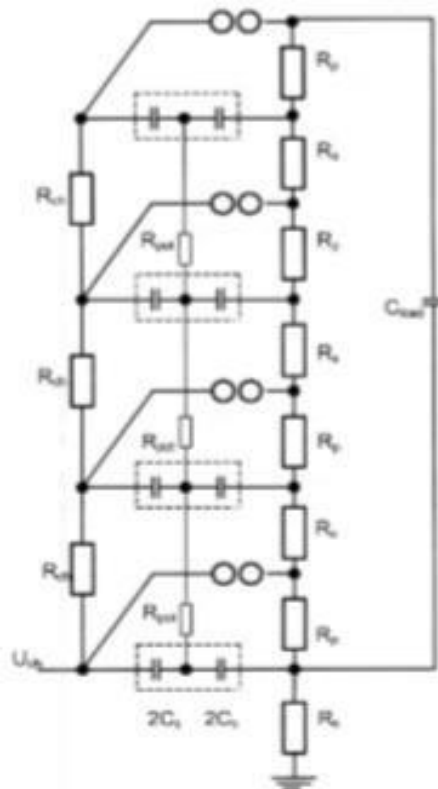

**Figure 6: Schematic diagram of impulse generator; Rch (4.7 kΩ): charging resistor. Rs (12.1 Ω): front resistor; Rp (67 Ω): tail resistor; Rpot (0.78 MΩ): potential resistor; Cs (2.0 μF): impulse capacitance; Cload=load capacitance**

### 3 Results and Discussion

This chapter discusses the results of testing a vessel in HVAC, HVDC, and impulse current using a Terco test transformer. Most high voltage tests require alternating voltages. The research is done either directly with this voltage or in a circuit for HVDC and impulse voltages. This chapter also discusses the chamber's endurance, leaking gas, and effectiveness after testing.

#### 3.1 Results and analysis HVAC and HVDC

Table 1 and Table 2 tabulated the results of HVAC Breakdown Voltage and HVDC Breakdown Voltage, respectively.

**Table 1: Result HVAC Breakdown Voltage**

HV test	HVAC		Electrode	Sphere- plane	
GAS	gas	CO <sub>2</sub>	configuration		
MIXTURE	30%	70%			
Gap length(cm)					
Breakdown	0.5	1.0	1.5	2.0	2.5
voltage	22.10	38.18	44.42	64.93	74.56
(kv/cm)	22.09	37.84	47.18	68.00	75.24
	23.04	37.48	44.45	68.58	77.92
	21.39	37.50	46.26	61.43	78.91
	23.19	38.83	45.13	61.57	79.72
	22.41	38.14	44.83	60.46	81.23

**Table 2: Result HVDC Breakdown Voltage**

HV test GAS MIXTURE	HVDC		Electrode	Sphere- plane	
	gas	CO <sub>2</sub>	configuration		
	30%	70%			
Gap length(cm)					
Breakdown	0.5	1.0	1.5	2.0	2.5
voltage	24.92	57.07	61.40	84.15	94.76
(kv/cm)	24.89	59.23	59.00	84.67	93.34
	24.67	56.42	65.30	85.91	96.68
	25.38	58.04	66.82	82.47	97.74
	24.69	53.40	65.91	88.54	96.69
	24.16	55.76	67.85	81.46	94.84

After doing HVAC and HVDC testing, we found that no leaking occurred, and the chamber was able to survive until the HVAC and HVDC testing was completed. This is measured by the amount of pressure that is given during HVAC and HVDC. Furthermore, the linear actuator works well during testing because the kite is able to adjust the gap length from 0.5 cm to 2.5 cm during HVAC and HVDC testing. These two tables show the full results of the testing conducted

3.2 Result and analysis Generation impulse voltage

Table 3 tabulated the result generation impulse voltage Breakdown Voltage

**Table 3: Result generation impulse voltage Breakdown Voltage**

HV test GAS MIXTURE	Impulse		Electrode configuration		Sphere- plane			
	N <sub>2</sub>	CO <sub>2</sub>	Pressure		2 bars			
Gap length(cm) and time								
	0.5	1.0	1.0 (µs)	1.5	1.5(µs)	2.0	2.0(µs)	2.5
Breakdown	45.2	50.0	6.730	54.0	8.610	67.8	7.902	64.4
voltage	44.4	46.8	-	52.4	-	62.8	0.538	59.6
(kv/cm)	43.6	50.0	4.526	54.0	5.944	60.4	-	66.0
	45.2	46.8	8.092	52.4	-	69.2	5.066	60.4
	44.4	46.0	-	54.0	8.962	66.0	7.254	67.6
	43.6	50.0	6.464	51.6	-	58.8	0.554	66.0
	41.2	49.2	-	54.0	6.696	58.0	-	69.2
	43.6	50.8	5.652	52.4	-	66.0	2.412	67.6
	40.4	49.2	7.000	54.0	-	62.8	4.872	64.6
	35.2	46.0	-	57.2	2.228	62.0	7.940	67.6
	40.4	51.6	3.972	56.4	1.032	61.2	0.940	66.0
	41.2	50.0	0.972	54.8	1.116	60.4	0.908	63.6
	40.4	49.2	-	51.6	12.722	58.0	13.006	61.2
	41.2	52.5	3.792	50.6	-	55.6	0.770	60.4
	40.4	46.8	-	54.0	2.176	54.8	-	65.2
	43.6	52.4	2.440	51.6	4.928	55.6	-	64.4
	41.2	49.2	6.982	50.0	-	58.8	6.358	60.4
	45.2	46.8	-	51.6	8.576	55.6	-	64.4
	44.4	52.4	3.070	50.0	-	58.8	9.330	61.2
	41.2	48.4	9.606	52.4	-	57.2	-	65.2

After performing the generation impulse voltage test, we found that no leakage occurred, and the space was able to survive until the generation impulse voltage test was completed although this time the test was quite long compared to the previous HVAC and HVDC. This is measured by the amount of pressure applied during the generation of impulse voltage. Furthermore, the linear actuator works well during the test because we can adjust the shape of the gap length from 0.5 cm to 2.5 cm during the generation impulse voltage test. Table 11 above shows the full results of the tests conducted

#### **4 Conclusion**

The objective of this project achieves successfully. A unique pressure vessel without any gas leakage with control measures has been designed particularly in current research work. The test chamber has three parts (i) test measurement involving a digital oscilloscope and capacitive divider (ii) control module, which comprises regulators, pressure gauges, and an air gap length controlling system. (iii) a pressure vessel for testing breakdown strength. Additionally, the test equipment can perform up to 5 bars of pressure tests. The use of a linear actuator allows an automatic air gap variation from outside without manually removing gases from the pressure vessel and adjusting an air gap. It reduces the time and eliminates the excessive costly usage of test gas. A successful experiment on buffer gases under alternating, Direct and impulse voltage tests is performed in the designed chamber. The pressure of the gases is varied and by utilizing the pressure gauge the leakage of gas is observed. It is concluded that no gas leak occurs during all these experiments. A variety of electrode configurations are required to investigate gas breakdown behaviour under a variety of electric fields because it is important to understand how gases behave under different electric fields. Consequently, the acquisition of a set of brass electrodes has also been made possible.

#### **Acknowledgement**

The authors would like to thank the Faculty of Electrical and Electronic Engineering, Universiti Tun Hussein Onn Malaysia, for its support.



## References

- [1] Kamarudin, M. S., H. Zainuddin, A. Haddad, R. Abd-Rahman, N. H. Radzi, A. Ponniran, and A. Zahari. "Purpose-built test rig for gas insulation breakdown tests under lightning impulse." In 2016 IEEE International Conference on Power and Energy (PECon), pp. 333-337. IEEE, 2016.
- [2] Ahmad, R., Abd Rahman, R., Salem, A. A., Jamail, N. A. M., Ab Rahman, A., & Hamid, H. A. (2021, October). Finite Element Analysis of Electric Field Distribution in C4F7N as an Alternative to SF6 For Electrical Insulation. In 2021 3rd International Conference on High Voltage Engineering and Power Systems (ICHVEPS) (pp. 126-131). IEEE.
- [3] Zahari, Ayuamira, Hidayat Zainuddin, Muhammad Saufi Kamarudin, Nur Farhani Ambo, Jamaludin Mohd Wari, and Imran Sutan Chairul. "Development of test vessel for gas insulation breakdown test." *International Journal of Power Electronics and Drive Systems* 9, no. 2 (2018): 873.
- [4] Kamarudin, Muhammad. "Experimental investigation of CF3I-CO2 gas mixtures on the breakdown characteristics in uniform and nonuniform field configurations." PhD diss., Cardiff University, 2013.
- [5] Khan, Bakhtiar, Jawad Saleem, Faisal Khan, Gul Faraz, Rizwan Ahmad, Naveed Ur Rehman, and Zahoor Ahmad. "Analysis of the dielectric properties of R410A gas as an alternative to SF 6 for high-voltage applications." *High Voltage* 4, no. 1 (2019): 41-48.
- [6] A. Beroual, Haddad. A, "Recent Advances in the Quest for a New Insulation Gas with a LowImpact on the Environment To." *Ener gies*, vol.10, no.8, pp.1216, 2017.
- [7] Ahmed, Rizwan, Rahisham Abd Rahman, Arshad Jamal, Ali Ahmed Salem, Bander Saman, Kwan Yiew Lau, and Sherif SM Ghoneim. "Field-Dependent Pollution Model under Polluted Environments for Outdoor Polymeric Insulators." *Polymers* 14, no. 3 (2022): 516.
- [8] X. Zhang et al, "Dissociative adsorption of environment-friendly insulating medium C3F7CN on Cu (111) and Al (111) surface: A theoretical evaluation," *Appl. Surf. Sci.*,vol. 434, pp. 549–560, 2018.
- [9] Ahmad, Rizwan, Faisal Khan, Arshad Jamal, Sikandar Khan, Sajid Ali, Mamon M. Horoub, and Ahmad Albalasie. "Simulation and breakdown characteristics of china clay and silica sand for improved grounding system." In 2020 International Conference on Electrical, Communication, and Computer Engineering (ICECCE), pp. 1-6. IEEE, 2020.
- [10] Sham, N. M. B., N. Z. Zahid, M. S. Kamarudin, N. A. M. Jamail, and R. Abd-Rahman. "Breakdown Characteristic of N2-CO2 Gas Mixtures under AC and DC Test Voltages." In *Journal of Physics: Conference Series*, vol. 1874, no. 1, p. 012027. IOP Publishing, 2021.