

# Comparative Study of Model Reference Adaptive Control (MRAC) and PID Controller for Regulation Temperature of Steam Distillation System

Aqilaa Silmi Amron<sup>1</sup>, Mohd Hafiz A. Jalil<sup>1\*</sup>, Rohaiza Hamdan<sup>1</sup>, Nur Suhadah Salehin<sup>1</sup>, Rafidah Ngadengon<sup>1</sup>

<sup>1</sup>Faculty of Electrical and Electronics Engineering,  
Universiti Tun Hussein Onn Malaysia, Batu Pahat, 86400, MALAYSIA

\*Corresponding Author Designation

DOI: <https://doi.org/10.30880/eeee.2021.02.02.074>  
Received 04 July 2021; Accepted 03 August 2021; Available online 30 October 2021

**Abstract:** Steam distillation is an important part of essential oil extraction. However, controlling the temperature at the correct temperature has proven difficult for the industry. Furthermore, if the extraction process is conducted to excessive heat, the essential oil quality will weaken. Therefore, the focus of this research to evaluate the performance of Model Reference Adaptive Control (MRAC) in regulating steam distillation temperature. The results reveal that the MRAC without integral outperforms the PID controller in preventing overshoot and providing a 40 % faster settling time when compared to the PID controller. This signifies that the MRAC is a controller that might be used to improve the steam distillation process for future work of steam distillation development.

**Keywords:** Model Reference Adaptive Control, PID Controller, Regulation Temperature, Steam Distillation System

## 1. Introduction

Compared to other algorithms such as solvent extraction, expression, and essential fluid extraction [1]-[2], steam distillation is the earliest and most common extraction method for most botanical materials [3]. The composition of essential oils obtained by steam distillation is 93% compared to the earlier 7% of essential oils obtained [1]. Although the steam distillation system is one of the traditional methods and was established a long time ago, due to factors such as operating cost, cleanliness, machine cost, efficiency and maintenance cost, it is still important and preferred in both industrial and research fields [4]. Usually, steam distillation is utilities to the ripe and unripe material [5].

Numerous experiments have been dictated to illustrate the effects of temperature on industrial oil production and temperature performs an important role in the distillation process [6]-[9]. Thus, temperature abstraction is either fixed or varies with temperature for each particular distillation process

and temperature indicates from the measurement that the production of essential oil will be affected. If the high temperature or long period of heat exposure to the extracted botanical plant during the extraction process, the oil yield may experience heat degradation during the distillation process. Additionally, the consistency of the chemical composition features of the oil will decline as it impacts the aromatic profiles of the oil and its physical colour.

Based on [8], temperature play major role in determine the successful of steam distillation process. This indicated that any improvement of temperature regulation in steam will benefit to improve overall steam distillation process. Therefore, this study only focuses on evaluation of MRAC performance in improving temperature regulation of steam distillation process.

## 2. Materials and Methods

### 2.1 System Modelling

One of the most important aspects in controller design is to obtain the transfer function of the system. In this work the model of the system is developed based on system identification. The input and output experimental data used for develop the model of the system is obtained based on study in [9]. The data has been split into two via interlacing approach where even data is used for the model, while the odd data is used to validate the model. The second-order transfer function was chosen as the model order for modelling the system. Based on the input and output experimental data and by using MATLAB version 2020a System Identification Toolbox , the second order transfer function for the heating process of steam distillation system obtained is as shown in Eq 1. Meanwhile Figure 1 shows the validation results based on best fits for the model in which it's have 91.73 per cent best fit.

$$G_m(s) = \frac{0.0008346}{s^2 + 0.00785s + 0.00004406} \tag{Eq.1}$$

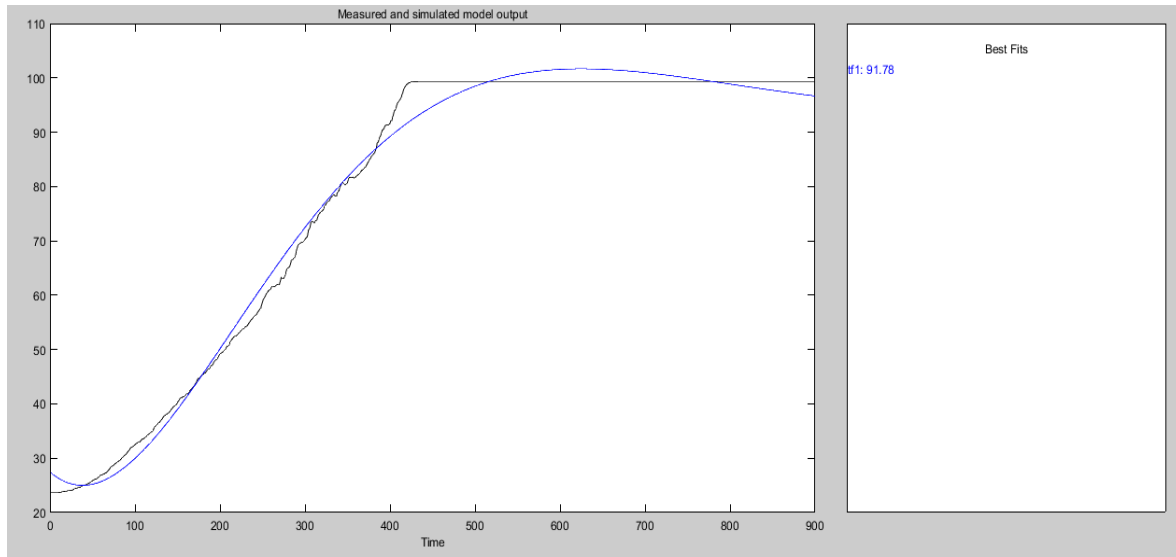

**Figure 1: The Measured and Simulated model output**

### 2.2 Model Reference Adaptive Control (MRAC) Design.

In this work the design of MRAC is based on the MIT rule [10]. Two MRAC block diagram used which the first MRAC block diagram is based on standard MIT rule as shown in Figure 2 and the second is a modified version of MRAC for MIT rules is as shown in Figure 3.

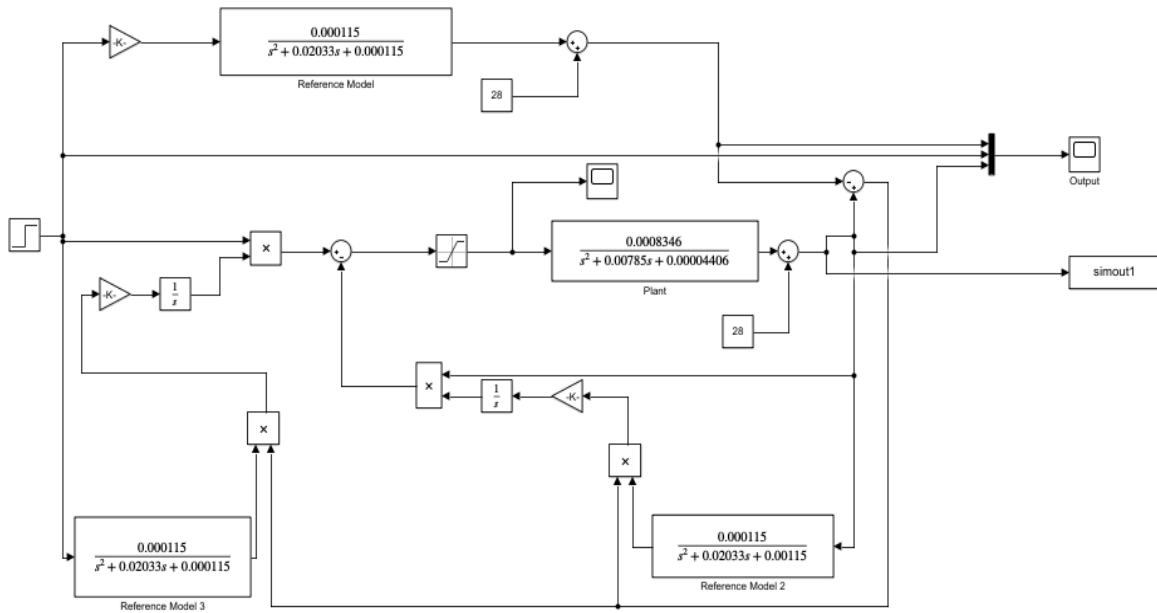

Figure 2: The Simulink design of MRAC

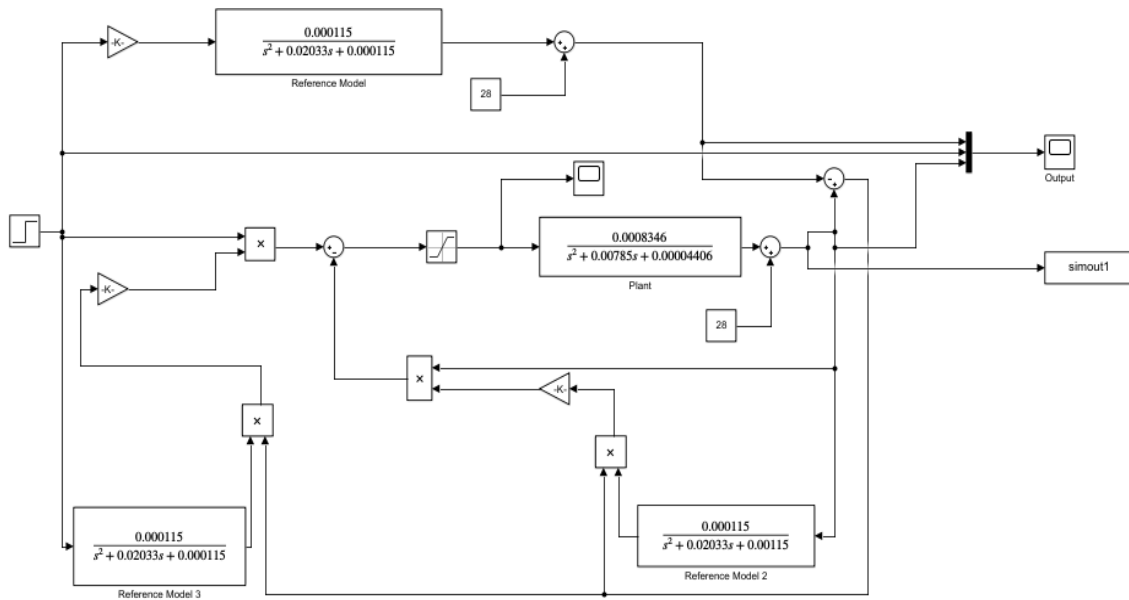

Figure 3: MRAC simulation in temperature regulation for a steam distillation process

2.2.1 Reference Model Design

The reference model used in this work has been design accordance with real output experimental data used for modeling. Based on the real data the undamped natural frequency obtained is 0.0107 while the damping ratio chosen is 0.95 to prevent the reference model output from overshoot. Based on the chosen value, the reference model applied for this work are as shown in Eq 2.

$$G_m(s) = \frac{0.000115}{s^2 + 0.02033s + 0.000115} \tag{Eq.2}$$

2.3 Proportional Integral Derivative (PID) Controller

In the PID controller design, the parameters of PID are tuned using Ziegler-Nichols (ZN) formula. Meanwhile the proses parameter namely Process Gain, Time Constant, and Time Delay parameter for the system is taken from previous studies [11]. Based on the process parameter, the calculated value of

PID parameter based on ZN tuning formula is tabulated in Table 1 whereas Figure 4 shows the PID block diagram implemented in this work.

**Table 1: The Parameter’s PID Controller Value**

Parameter	Gain
Proportional Gain, Kp	0.2442
Integral Gain, Ki	0.00034
Derivative Gain, Kd	0.2035

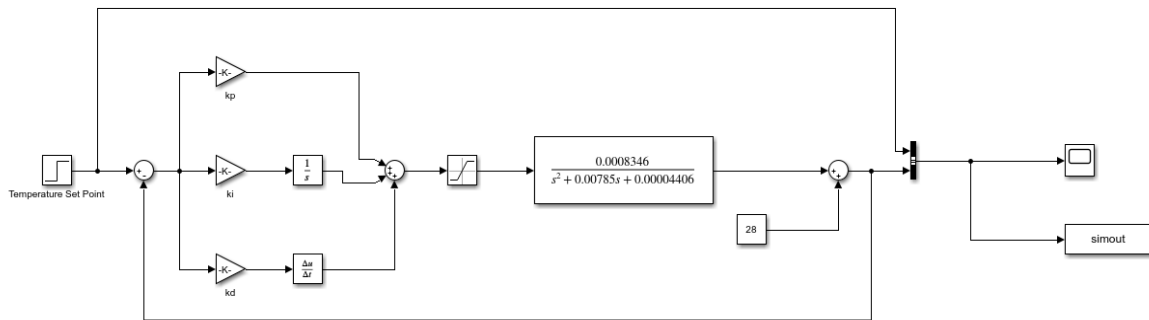

**Figure 4: The PID Controller structure in Simulink**

#### 2.4 The Controller Performance Analysis

In this work, the analysis of the controller performance is based on transient analysis known as 2%band settling time, rise time and percentages overshoot. Settling time is the period needed to reach the steady state of the response and remain around the final value within the defined tolerance bands [12] while, Rise Time, Tr is defined as the time taken to go from 10% to 90% of the final value  $c(\infty)$  for the performance. This is characteristic with underdamped devices. Consider the period of 10 percent to 90 percent of the final value for the over-damped systems [13]. Finally, the overshoot refers to an answer above the final value (set point)  $c(\infty)$  and can be determined using the following formula. Where c is the maximum response amplitude that usually occurs during the first peak. The description of the scheme is generally described in terms of percentages. This can be done by multiplying the above equation by 100%. The percentage overshoot Eq. 3 can therefore be rewritten as follows.

$$\% \mu = \frac{c(\max) - c(\infty)}{c(\infty)} \tag{Eq.3}$$

### 3. Results and Discussion

All of the outcomes from the simulations that have been run are examined and analyzed in this section. The findings of this study are meticulously reviewed to achieve the study's goals. In MATLAB/Simulink, the performance of both controllers was simulated and analyzed using performance indices.

#### 3.1 PID Controller Performance Analysis

Figure 5 shows the performance PID controller in regulating temperature for steam distillation system. The analysis of the response is as tabulated in Table 2. From the analysis it show that PID controller provide high percentages overshoot which equal to 14.4%. On the other hand, the analysis

shows that PID controller required long time to achieved settling time which is 2960 second. Based on this results it clearly shows that PID controller does not capable to provide good performance such as low percentages overshoot and fast settling time. Therefore the implementation of advanced controller such as MRAC is needed toward improving the performance of regulating temperature of steam distillation system.

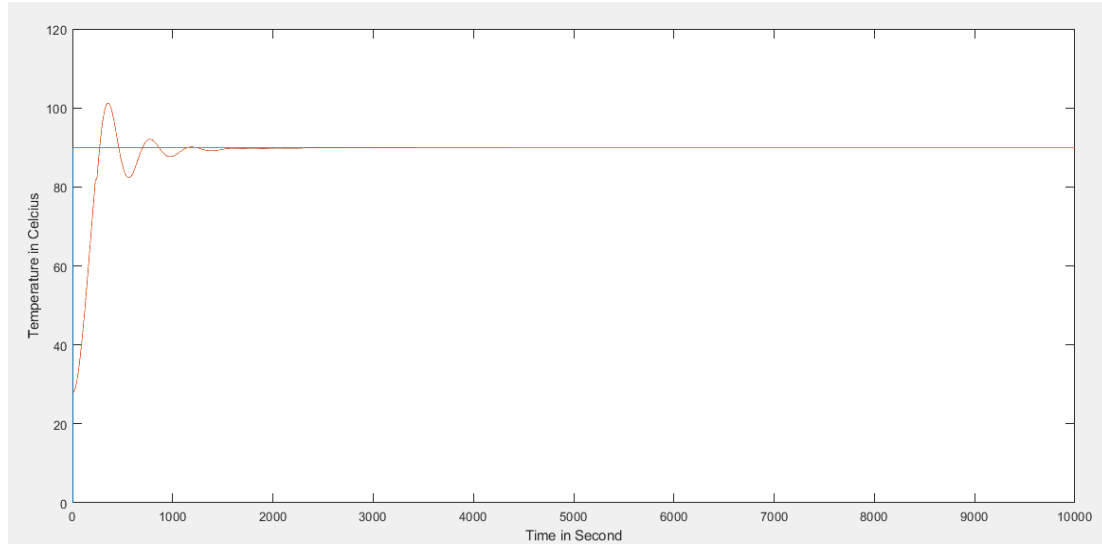

**Figure 5: The performance PID controller in regulating temperature for steam distillation system**

**Table 2: The step response for the PID controller**

Settling Time, $T_s$	Rise Time, $T_r$	Percentages Overshoot
1067s	185s	12.47%

### 3.2 Model Reference Adaptive Control (MRAC)

The curve of time response with integral is depicted in Figure 6. The MRAC has to be modified because that MRAC does not work effectively and does not produce a sustained response. Several adaptation gains have been tested to obtain the optimal value of adaptation gain to find the best tuning in providing better performance in regulating the temperature of the distillation system.

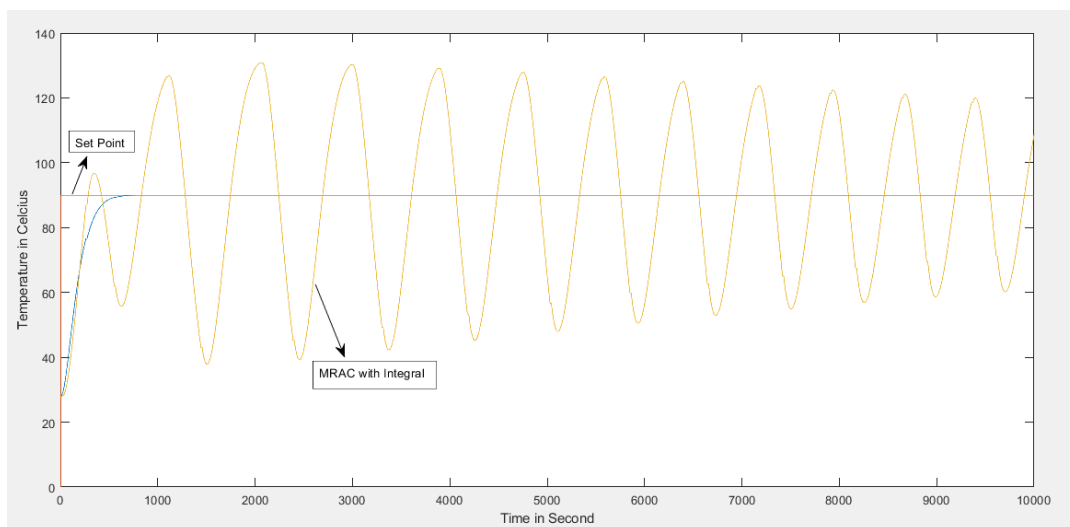
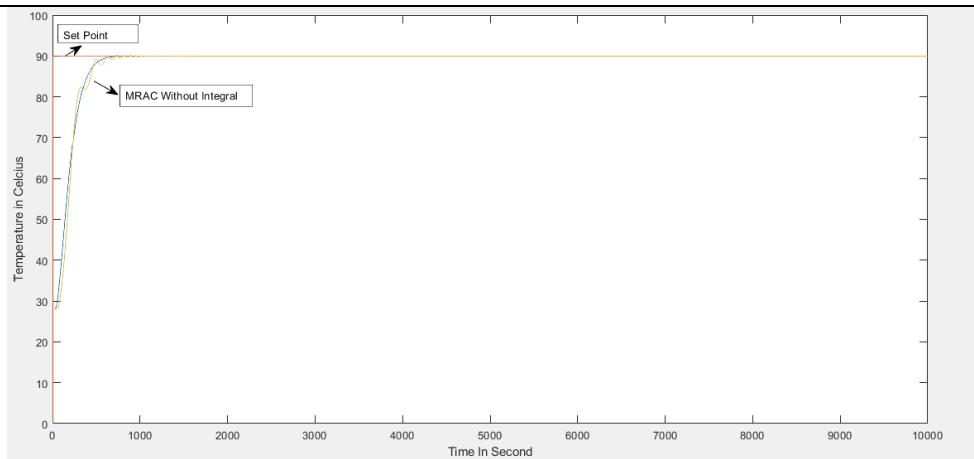

**Figure 6: The curve of time response (with integral)**

By using the try-and-error method, the MRAC based on the MIT adaption gain was set to begin at  $\pm 0.01$  in simulation. The goal of varying adaptation gain in simulation is to discover the proper adaptation value for the best performance indices. Table 3 contains the facts of MRAC's performance with different adaptation gains while, MRAC's ideal adaptation gain is shown in Figure 7. The crop's attributes have significantly improved. In the system response, there are no oscillations.

**Table 3: The performance with different adaptation gains**

No	Adaption Gain	Settling Time, Ts	Rise Time, Tr	Percentages Overshoot
1	$\pm 0.01$	592.12	313.87	0.2521
2	$\pm 0.05$	569.38	307.90	0.2548
3	$\pm 0.005$	612.93	319.60	0.3066



**Figure 7: The performance of MRAC in regulating temperature for steam distillation system**

### 3.3 The Comparative Analysis

Simulink software was used to create a simulated PID and MRAC for temperature regulation for both controllers. The system's initial set point was set to 90°C. As demonstrated in Figure 8, both controllers output performance reaches the set point differently. The time it takes for the PID system to achieve the intended set-point is longer. MRAC, on the other hand, does not appear to have overshoot and has a faster rise time than PID. In terms of overall performance, the MRAC controller outperformed the PID controller. Table 4 lists the performance of both controllers.

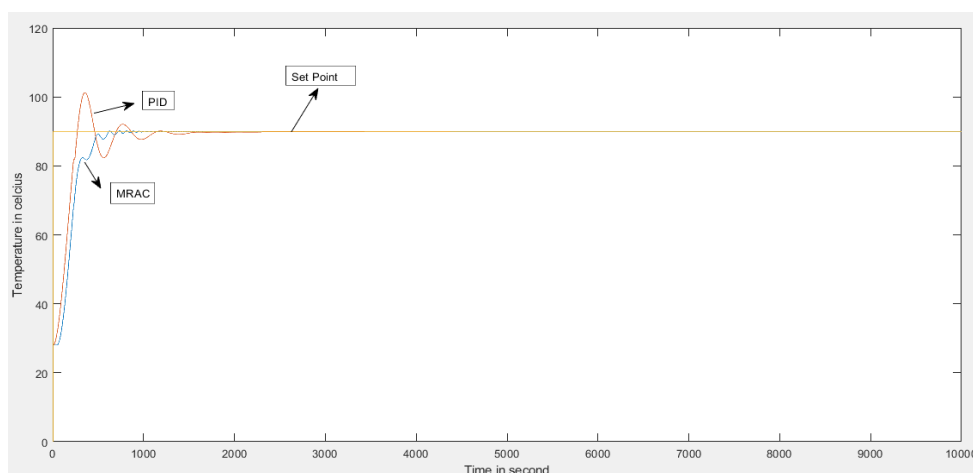

**Figure 8: The PID and MRAC output responses.**

**Table 4: The performance of the both controllers**

	<b>Settling Time, Ts</b>	<b>Rise Time, Tr</b>	<b>Percentages Overshoot</b>
Model Reference Adaptive Controller (MRAC)	592.12s	313.87s	0.2521%
Proportional Integral Derivate (PID)	1067.4s	185.82s	12.479%

Table 4 compares the performance of the both controllers. The simulated results reveal that a traditional PID controller can regulate the processing system. Still, it has flaws compared to a second-order MRAC based on the MIT technique with the best selection adaption gain,  $\pm 0.01$ . The PID's flaw is that it has an overshoot and a long settling period, lowering the quality of essential oils during the heating process. The temperature should not reach the desired temperature throughout the extraction procedure to maintain the quality of essential oils. As a result, the conventional PID controller took less time to achieve the set-point, 185.82 seconds versus 313.87 seconds for MRAC, while MRAC took less time to settle the response, 592.12 seconds versus 1067.4 seconds for PID. Compared to a PID controller, the MRAC system more robust in performance compared to a PID controller. The reason for this is that the MRAC system retains track of the model reference even when the set-point is altered, but a PID controller with fixed parameter gains cannot follow the desired set point when the set-point is changed. In terms of overall performance, implementing a second-order MRAC system based on the MIT approach outperformed a standard PID controller.

#### 4. Conclusion

The simulation study indicates that the standard MRAC does not perform well. However, the modified version MRAC which is MRAC without integral provides more remarkable performance. The comparison with a PID controller clearly shows that MRAC without an integral delivers better performance. This implies that MRAC without integral is one of the controllers that can be used in improving temperature regulation of a steam distillation system that can contribute in increasing overall effectiveness of steam distillation process.

#### Acknowledgement

The authors would like to thank the Faculty of Electrical and Electronic Engineering, Universiti Tun Hussein Onn Malaysia for its support.

#### References

- [1] H. Ebrahimzadeh, Y. Yamini, F. Sefidkon, M. Chaloosi, and S. M. Pourmortazavi, "Chemical composition of the essential oil and supercritical CO<sub>2</sub> extracts of *Zataria multiflora* Boiss," *Food Chemistry*, vol. 83, pp. 357–361, 2003.
- [2] F. Peng, L. Sheng, B. Liu, H. Tong, and S. Liu, "Comparison of different extraction methods: steam distillation, simultaneous distillation and extraction and headspace co-distillation, used for the analysis of the volatile components in aged flue-cured tobacco leaves," *Journal of Chromatography A*, vol. 1040, pp.1–17, 2004.
- [3] P. Masango, "Cleaner production of essential oils by steam distillation," *Journal of Cleaner Production*, vol. 13, pp. 833-839, 2005.
- [4] N. Kasuan, M. Yunus, M. H. F. Rahiman, S. R.S.Aris, and M. N. Taib, "Essential Oil Composition of Kaffir Lime: Comparative analysis between Controlled Steam Distillation and Hydrodistillation Extraction Process," *Proceedings of 2009 Student Conference on Research and Development (SCORED 2009)*, 2009.

- [5] M. Rouatbi, A. Duquenoy, and P. Giampaoli, "Extraction of the essential oil of thyme and black pepper by superheated steam," *Journal of Food Engineering*, vol. 78, pp. 708–714, 2007.
- [6] Baher, Z. F., Mirza, M., Ghorbanli, M., & Rezaii, M. (2002). The influence of water stress on plant height, herbal and essential oil yield and composition in *Satureja hortensis* L. *Flavour and Fragrance Journal*, 17(4), 275–277.
- [7] H. Ebrahimzadeh, Y. Yamini, F. Sefidkon, M. Chaloosi, and S. M. Pourmortazavi (2003). Chemical composition of the essential oil and supercritical CO<sub>2</sub> extracts of *Zataria multiflora* Boiss. *Food Chemistry* 83: 357-361.
- [8] A. Doneliana, L. H. C. Carlsonb, T. J. Lopes, and R. A. F. Machado. (2009). Comparison of extraction of patchouli (*Pogostemon cablin*) essential oil with supercritical CO<sub>2</sub> and by steam distillation. *J. of Supercritical Fluids* 48: 15-20
- [9] M. Z. Ozel, F. Gogus, J. F. Hamilton, and A. C. Lewis (2005). Analysis of volatile components from *Ziziphora taurica* subsp. *Taurica* by steam distillation, superheated-water extraction, and direct thermal desorption with GCxGC/TOFMS. *Anal Bioanal Chem* 382: 115-119.
- [10] H. Ebrahimzadeh, Y. Yamini, F. Sefidkon, M. Chaloosi, and S. M. Pourmortazavi, "Chemical composition of the essential oil and supercritical CO<sub>2</sub> extracts of *Zataria multiflora* Boiss," *Food Chemistry*, vol. 83, pp. 357–361, 2003.
- [11] Z. M. Yusoff, Z. Muhammad, and M. N. Taib, "Steam Temperature Control of Hydro-diffusion Essential Oil Extraction System using Hybrid-Fuzzy plus PID Controller," *IEEE Conf. Syst. Process Control (ICSPC 2014)*, no. December, pp. 12–14, 2014.
- [12] Mazidah Tajjudin, Mohd Hezri Fazalul Rahiman, Norlela Ishak, Ramli Adnan, 'Model Evaluation of a Steam Distillation Process for Steam Temperature Regulation' 2012 Third International Conference on Intelligent Systems Modelling and Simulation.
- [13] Mohd Hafiz Bin A. Jalil @ Zainuddin, "Process Control", 2021.