

A Portable Non-Invasive Blood Glucose Monitoring Device with IoT

Siti Nur Shahidah binti Anis¹, Rozlan BinAlias^{1*}

¹Faculty of Electrical and Electronic Engineering,
Universiti Tun Hussein Onn Malaysia, 86400 Parit Raja, MALAYSIA

*Corresponding Author Designation

DOI: <https://doi.org/10.30880/eeee.2021.02.01.005>

Received 11 February 2021; Accepted 05 April 2021; Available online 30 April 2021

Abstract: Diabetes Mellitus is one of the most life-threatening diseases worldwide and can affect anyone regardless of their age. To avoid the high risk of diabetics, it is important to monitor blood glucose levels regularly. Nowadays, there are many types of blood glucose gauges in health centers that help patients with high blood glucose problems monitor their blood glucose levels. However, most blood glucose measuring devices on the market are invasive, involving finger piercings. This method is high in accuracy but is usually painful and has a higher risk of infections. Therefore, to avoid the anxiety of the invasive glucose monitoring system, it is desirable to develop non-invasive blood glucose monitoring at a low cost. Alternatively, non-invasive techniques were introduced to develop painless glucose measurement methods [1]. In this project, a portable non-invasive blood glucose monitoring device was developed using near infrared sensors. This sensor is placed at the fingertip to optionally measure blood glucose and blood glucose concentrations are calculated depending on the intensity of light received. The signal is then filtered and amplified before being inserted into the microcontroller. The glucose level of the patient was predicted based on the analyzed voltages received and data of glucose to be displayed on the LCD and was sent to a mobile phone via Wi-Fi. It's displayed through an Android application like Blynk Apps. The Experiment of Glucose Concentration Calibration is showed that these two variables have a negatively strong linear relationship, voltage decreases as glucose concentration increases. Lastly, the percentage difference obtained from the reliability test was less than 25%, which proved that the non-invasive technique was implemented in the device is reliable to measure blood glucose concentration.

Keywords: Blood Glucose Meter, Non-invasive technique, IoT – based monitoring

1. Introduction

According to the World Health Organization (WHO), around 400 million people worldwide live with diabetes and the rate is only projected to continue to increase if existing trends persist. The main adverse effects for diabetics are fatal injury, blindness, insufficient renal function, heart problem, stroke and lower limb amputation. It was the 7th leading cause of death in 2016 [2-3].

*Corresponding author: rozlan@uthm.edu.my

2021 UTHM Publisher. All rights reserved.

publisher.uthm.edu.my/periodicals/index.php/eeee

Diabetes Mellitus is one of the most life-threatening diseases in the world. There are three types of diabetes, including Type I diabetes, which is the most severe diabetes. The human body does not produce insulin, and insulin must be injected daily into the body. It is usually developed in infancy and adolescence. Second, Type II diabetes is where the body does not produce enough insulin [4]. It also causes heart disease, stroke, blindness, and impaired kidneys. It develops mainly in obese and adults. Thirdly, Type III diabetes is pregnancy-related diabetes. During pregnancy, the glucose concentration in the blood is higher than usual. Recent research has shown that the risk of diabetes can be decreased by continually monitoring and controlling blood glucose levels. Therefore, patients are encouraged to monitor portable blood glucose at home. Three glucose measurement methods are invasive, minimally invasive, and non-invasive.

The standard invasive method that exists today must take a blood sample from the patient or subject by pricking the fingertip, where this procedure causes pain in the patient and can damage the finger's cells or tissue [5].

Thus, the development of a non-invasive glucose surveillance device will include sensing technology with the application of near-infrared light-emitting diode, photodiode S5971, and ESP8266 NodeMCU. It is simple and easy for the human body to measure blood glucose levels. This project involves using almost-infrared light to measure the glucose concentration in the blood fingertips by absorbing and disperse the light through the blood process. The procedure can also provide painless, convenient, and economical alternatives to these devices; its high skin penetration, more desirable, and excellent [6].

2. Methodology

2.1 Project Overview

The project implementation can be divided into the hardware and the software part. The hardware part includes a build prototype with completed circuit design for the transmitter circuit, and receiver circuit. While, the software consists part of the Arduino IDE programming for controller of the project, NI Multisim Software as platform to design schematic diagram, and SketchUp Software as platform to design prototype model project. Figure 2.1 show the block diagram for non-invasive glucose monitoring device and Figure 2.2 show the flow chart of a Portable Non-Invasive Blood Glucose Monitoring Device.

The device process was initiated once there is a power supply in at input. Next, this device needs the user to press the start button to begin the process. Insert any finger at the sensor location, or both of the sensor devices. Infrared LED devices and photodiode devices is always placed parallel to the finger so that the light can be transferred through the finger and the photodiode can be detected [7]. A photodiode will therefore receive an infrared signal that would be converted to a relative voltage value. Also, the transmitter LED used is an IR light emitter from element14 that has a wavelength of 1023 nm. An Indium Gallium Arsenide (InGaAs) from photodiode (S5971) is an element14 where it has a high reaction around 1000 nm wavelength has been used as a receiver [8]. The Light transmitters and receivers at a wavelength of 1023 nm are significantly less expensive compares favorably to other wavelengths with equivalent or higher glucose response.

In addition, the NodeMCU as a microcontroller will use these photodiode voltage values as a variable to measure the glucose concentration and evaluate its level based on the mathematical equation in the programming process. The value of glucose concentration will be in mg/dL. Finally, the data of concentration glucose will be sent to the internet via NodeMCU Wi-Fi Module ESP8266 then displayed on a mobile phone by using the Blynk application, IoT platform, and displayed at LCD.

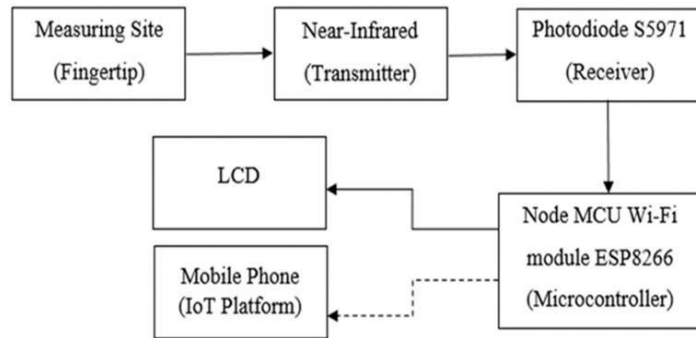

Figure 1: Block diagram for non-invasive glucose monitoring device

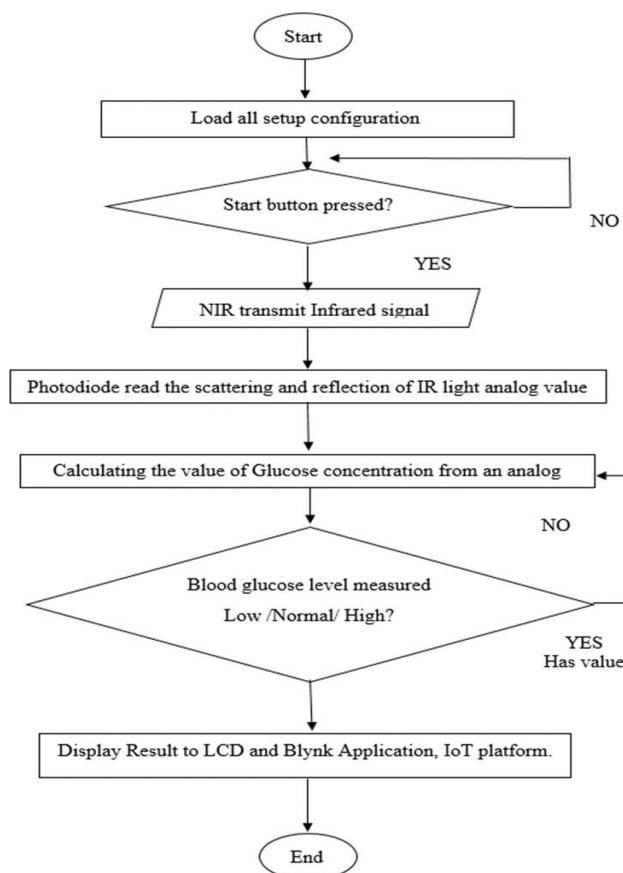

Figure 2: Flow chart of a Portable Non-Invasive Blood Glucose Monitoring Device

2.2 Hardware development

An electronic circuit was implemented to obtain the near infrared (NIR) spectral range for the blood glucose measurement. The circuit was powered by 5V. This circuit can be divided into two parts which is transmitter circuit (IR Light Emitter) and receiver circuit (Photodiode S5971) [9]. The transmitter circuit used a resistor act as limit the current that can flow through LED. The receiver circuit known as detector circuit are used a few of combinations circuit which is the RC filter (R2 and C1) is connected to the photodiode to filter DC power supply.

Then, R3 is the load resistor (RL) and it will affect the voltage output. After that, the value of the output voltage will be increase by increasing the value of RL. The different voltage values will be recorded due to the different of blood glucose. In addition, based on previous paper the noise filter circuit was constructed and an amplifying circuit were implemented to ensure a better signal quality was obtained. The both circuit was added to obtain a gain of 11. Then, operational amplifier LM 324N was selected due to its high gain and it could operate from a single power supply. The filter and amplifier circuits are shown in Figure 2.3 below [10].

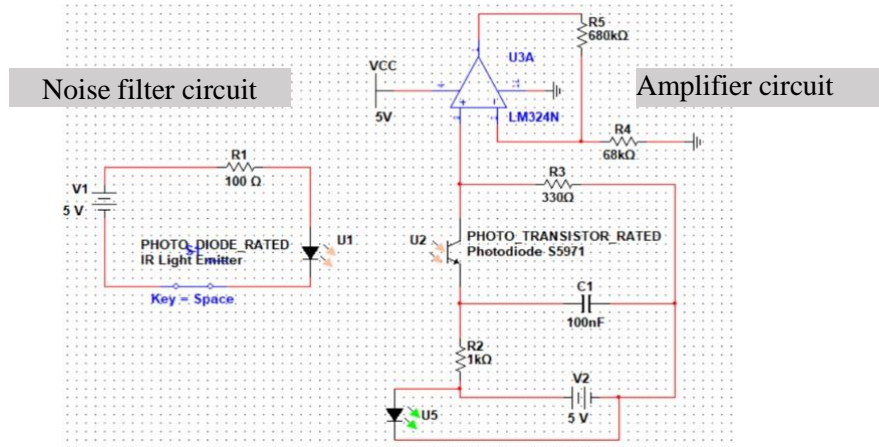

Figure 3: Noise filter circuit and amplifier circuit

2.2.1 Prototype Design

From this project, the prototype was designed as show in Figure 2.4. After that, the figure below shows that the design of the project prototype consists entirely of a circuit board attached to the ESP8266 NodeMCU microcontroller NIR transmitter and receiver circuit. Other components like LCD and LEDs with different colors were integrated. For example, a red LEDs was illuminated when the sensor detected a high glucose concentration, a green LEDs was illuminated when the glucose concentration sensor detected a normal glucose concentration and a yellow LEDs was illuminated when a low glucose concentration sensor was detected. Besides, the main body structure for this project whereit made of plastic material. This body structure is very modular to modify at a future time for any suitable changes that may occur. Then, a finger placeholder was built to ensure measurement more consistent and accurate from the sensor. The hardware design is a portable and user friendly because the component inside it is arranged neatly and tightly. This project is lightweight and not heavy, allowing users to move inside or outside the house or workplace anywhere.

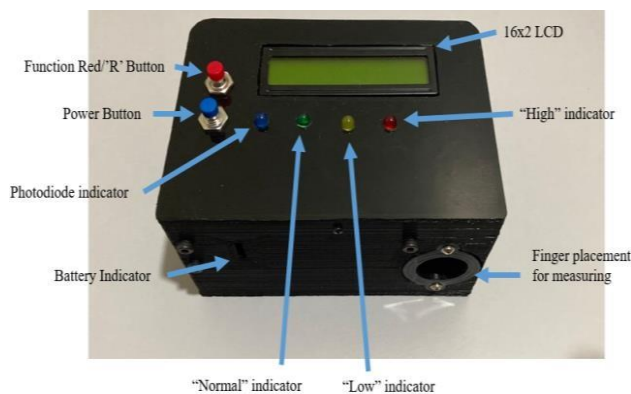

Figure 4: Prototype of a non-invasive blood glucose monitoring device

2.3 Software development

There have been several software applications that used build up a non-invasive glucose monitoring device for software development. First, NI Multisim software is used to create the circuit design and could be used as a platform to simulate the programming of the microcontroller [11]. Next, SketchUp software in which this software is being used to construct a prototype 3D model for the project [12]. Finally, The Arduino IDE software operates to write programming code and upload code programs [13].

2.3.1 IoT Features

IoT is a physical system which could monitor, controlling, or communicate and can subsequently be linked to the worldwide Web. In this project, Blynk App is used as the internet of things platform (IoT) because it is easier to understand for projects and cheaper than others. Blynk has a complete set as it has servers, apps and is easy to connect.

2.3.2 Android App Design

Glucose meter android applications are developed to provide glucose concentration readings on the phone. It allows user readings to be shared with family members or doctors if needed. The glucose meter mobile application was developed using the Blynk Application. The user interface for the developed application is shown in Figure 2.5.

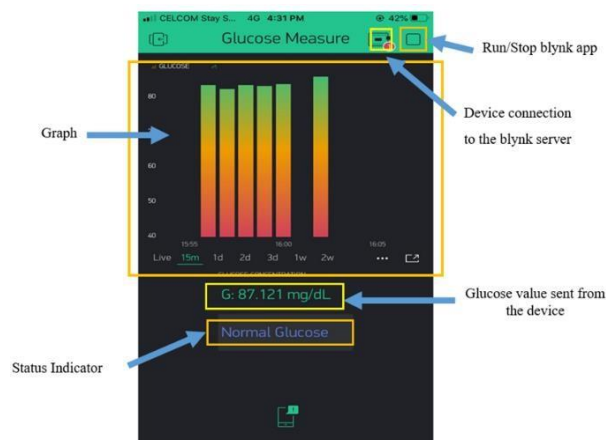

Figure 5: The user interface for the developed application

3. Results, Analysis and Discussion

3.1 Experiment of Glucose Concentration Calibration Curve

Before displayed the glucose concentration reading, the data is processed and analyzed as show in Table 3.1. The experiment was performed to investigate the interaction between both the glucose level and the output voltage. Throughout this research project, a few glucose solutions with different concentrations ranging from 10 to 100 mg/dL were prepared and dissolved with glucose such as glucolin in 100 ml of distilled water. Stir the glucose with distilled water and leave for a few seconds until the material dissolves perfectly. Next, the solution was put into a cuvette and placed as shown in Figure 3.1.

The relationship between the concentration of glucose and the voltage was calculated from the findings by applying regression analysis. The analysis identified an equation that relates to the concentration of glucose and the values of the voltages. Based on the voltage value obtained from the sensor, this equation (3.1) was used in coding to predict glucose concentration.

$$y = -36.895x + 92.191 \tag{3.1}$$

The value of the regression analysis obtained from the graph in Figure 3.2 is 0.9999. The value is also called a coefficient of determination. The result means that the value is closely approaching 1. This indicates a strong linear relationship between both the voltage-dependent variable (x) and the glucose concentration (y), where 99.9979% of glucose concentration depends on the voltage value. After that, the Pearson correlation coefficient is -0.99998. The values between $\pm 0.5 < r < \pm 1$. It shows a good Correlation. The findings showed that both the glucose concentration and the voltage value also have a negatively strong linear relationship [14].

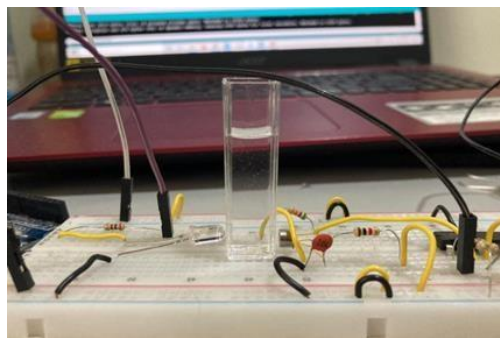

Figure 6: Glucose calibration experimental setup

Table 1: Dataset of glucose concentration (mg/dL) with the voltage (mV)

No	Glucose value (mg/dL)	Voltage value (mV)
1	10	2.21
2	20	1.97
3	30	1.66
4	40	1.40
5	50	1.16
6	60	0.85
7	70	0.62
8	80	0.31
9	90	0.07
10	100	-0.19

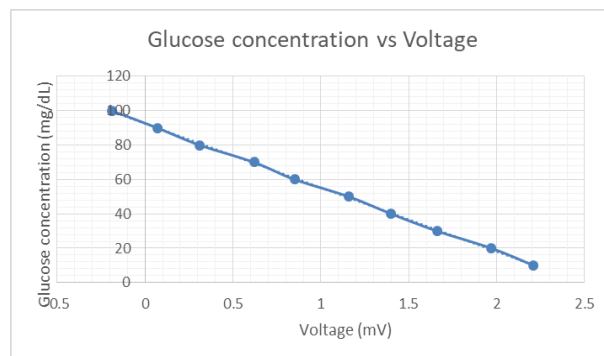

Figure 7: Relationship between glucose concentrations (mg/dL) and voltage (mV)

3.2 Experiment of Invasive vs. Non-invasive Reliability Tests

The reliability analysis was conducted on 10 non-diabetic individuals using both invasive techniques by using the ACCU-Check device and the non-invasive technique with a portable non-invasive blood glucose monitoring device. Table 3.2 and 3.3 compares the glucose readings from two method designs. After the completion of the measurement process, the calculation work on the percentage difference is made for each reading to make a comparison between the two techniques using equation (3.2).

$$\text{Percentage error (\%)} = \frac{\text{Glucose invasive} - \text{Glucose non-invasive}}{\text{Glucose non-invasive}} \quad (3.2)$$

Out of the results, the percent difference for glucose measurements using two different methods with both an invasive technique and a non-invasive technique it's no more than 25%. On average, the percentage error is 13.56% based on 10 tests in random time and 14.29% based on 10 test after mealtime. In addition, the percentage values obtained from the experiments may differ due to several factors, including the results of the calibration curve test obtained from the measurement of glucose solutions that do not contain other substances such as in the blood. Furthermore, factor from users also tends to affect the glucose measurements because each individual has various skin thickness in which influences the absorption of the infrared signal. Finally, the environmental factor could be due to the dispersion of the infrared signal into the environment, which makes the photodiode less able to receive the effect.

Table 2: Comparison of glucose concentration measurement using invasive and non-invasive technique in random time.

No.	SUBJECT	Glucose concentration measurements			Percentage Error (%)
		Invasive (mmol/L)	Non-Invasive (mg/DL)	Non-Invasive (mmol/L)	
1.	A	6.1	88	4.9	24.49
2.	B	6.8	108	6	13.33
3.	C	5.4	87	4.8	12.5
4.	D	6	92	5.1	17.65
5.	E	5.2	88	4.9	6.12
6.	F	5.6	82	4.5	24.44
7.	G	7	112	6.2	12.90
8.	H	5.2	86	4.7	10.64
9.	I	4.8	76	4.2	14.29
10.	J	4	75	4.1	2.44
Mean		56.1	49.4		13.56

Table 3: Comparison of glucose concentration measurement using invasive and non-invasive technique in after meal.

No.	SUBJECT	Glucose concentration measurements			Percentage Error (%)
		Invasive (mmol/L)	Non-Invasive (mg/DL)	Non-Invasive (mmol/L)	
1.	A	7.3	122.4	6.8	7.35
2.	B	7	115.2	6.4	9.375
3.	C	6.8	90	5	36
4.	D	7	111.6	6.2	12.9
5.	E	6.1	96	5.3	15.09
6.	F	5.4	85	4.7	14.89
7.	G	6.9	115.2	6.4	7.81
8.	H	6.5	102.6	5.7	14.04
9.	I	6	86	4.8	25
10.	J	5	84.6	4.7	6.38
Mean		64	56		14.29

3.3 Cost Analysis

One of the purposes of this project was to create a low-cost non-invasive glucose monitoring device. This is because the invasive device is expensive than the non-invasive blood glucose where the price of invasive devices like ACCU-CHECK Performa is above RM250. Therefore, the cost of this project is RM66.13 and it achieved with lower than the price that has been in the current market. So, a diabetic person was able to buy it at an affordable price and used it at home. This product also in the range of the budget product which is to avoid any loss. Table 3.4 below show the bill of materials of the project.

Table 4: Bill of materials

No	Item name	Quantity	Unit Cost (RM)	Total (RM)
1	Resistor 68k Ω , 680k Ω , 1k Ω , 330 Ω , 100 Ω	1	RM0.05	RM0.25
2	Ceramic Capacitor 100nF	1	RM0.08	RM0.08
3	Light emitting diode	4	RM0.78	RM3.12
4	Battery Rechargeable 3.7V (2000mAh, 7.4wh)	1	RM10.20	RM10.20
5	Arduino LCD Display 16x2 (Yellow backlight)	1	RM7.00	RM7.00
6	NODEMCU ESP8266	1	RM40.00	RM40.00
7	Photodiode (S5971)	1	RM0.02	RM0.02
8	5mm Infrared IR LED Light Emitting Diode 940nm	1	RM0.46	RM0.46
9	MD-SERIAL I2C Module for Character LCD	1	RM5.00	M5.00
Total cost				RM66.13

4. Conclusion

Overall, non-invasive blood glucose monitoring device that is a pain-free glucose measuring system using Near-Infrared Spectroscopy. Data from the glucose meter is sent via Wi-Fi to their smartphone and displayed on a user-friendly Android app. It can help patients remotely without the need to come hospital, save time, and cost. This device is not only useful for individuals that have diabetes, but also for all individuals to maintain their glucose levels at normal levels in order to ensure a healthy lifestyle. A suggestion for future advancement was to overcome the precision of the device. The value of output voltage from photodiode has accuracy when doing testing glucose concentration in a darker place. Some other suggested solution is to use a component which has a high wavelength to transfer a signal and reach glucose in circulatory system like a laser.

Thus, in addition to the technique of absorption, another technique that can be used is the technique of reflection. This method will provide a more accurate reading of glucose concentration detection. Finally, improve the development of the glucose meter system by providing insulin based on the predefined parameters set by the program.

Acknowledgement

The author would like to thanks the Faculty of Electrical and Electronic Engineering, Universiti Tun Hussein Onn Malaysia for the facilities especially Mechatronic Laboratory that has been provided to complete this project and for its support.

References

- [1] Rahmat, M. A., Su, E. L. M., Addi, M. M., & Yeong, C. F. (2017). GluQo: IoT-based non-invasive blood glucose monitoring. *Journal of Telecommunication, Electronic and Computer Engineering (JTEC)*, 9(3-9), 71-75.
- [2] World Health Organization, "Global Report on Diabetes," [Online]. Available: <http://www.who.int/mediacentre/factsheets/fs312/en/>. 2016.

- [3] D. R. Whiting, L. Guariguata, C. Weil, and J. Shaw, "IDF Diabetes Atlas: Global estimates of the prevalence of diabetes for 2011 and 2030," *Diabetes Res. Clin. Pract.*, vol. 94, no. 3, pp. 311–321, 2011.
- [4] Gayathri, B., Sruthi, K., & Menon, K. U. (2017, April). Non-invasive blood glucose monitoring using near infrared spectroscopy. In *2017 International Conference on Communication and Signal Processing (ICCSP)* (pp. 1139- 1142). IEEE.
- [5] Kaleeswari, D., Nandhini, S., Sajna, M., Usha, R., & Premkumar, M. (2017). Detection of blood glucose level for type 1 diabetic patient by using noninvasive breath measurement. D. Kaleeswari al. *International Journal of Recent Research Aspects* ISSN, 2349-7688
- [6] Yadav, J., Rani, A., Singh, V., & Murari, B. M. (2014, February). Near-infrared LED based non-invasive blood glucose sensor. In *2014 International Conference on Signal Processing and Integrated Networks (SPIN)* (pp. 591- 594). IEEE.
- [7] K. J. Jeon, I. D. Hwang, S. Hahn, and G. Yoon, "Comparison between transmittance and reflectance measurements in glucose determination using near-infrared spectroscopy," *Journal of Biomedical Optics*, no. 11, p. 014022, 2006
- [8] Burmeister, J. J., Chung, H., & Arnold, M. A. (1998). Phantoms for noninvasive blood glucose sensing with near infrared transmission spectroscopy. *Photochemistry and photobiology*, 67(1), 50-55.
- [9] O.Olarte and K.Barb (2013).Glucose Detection in Human Sweat Using an Electronic Nose. *Engineering in Medicine and Biology Society (EMBC)*, IEEE. pp. 1462–1465.
- [10] Abd Salam, N. A., Saad, W. H. M., Manap, Z., Salehuddin, F., & Karim, S. A. A. (2018). Comparative Study of Different Near-Infrared (NIR) Wavelengths on Glucose Concentration Detection. *Journal of Telecommunication, Electronic and Computer Engineering (JTEC)*, 10(2-6), 59-64.
- [11] QU, B. Z., ZHANG, J. T., & LIU, Y. Z. (2009). Simulation analysis and design of circuits based on Multisim [J]. *Journal of Henan Polytechnic University (Natural Science)*, 3.
- [12] What Is Sketchup (and How Do I Use It)? Brady Gavin - <https://www.howtogeek.com/364232/what-is-sketchup/>
- [13] Lawand, K., Parihar, M., & Patil, S. N. (2015, December). Design and development of infrared LED based non-invasive blood glucometer. In *2015 Annual IEEE India Conference (INDICON)* (pp. 1-6). IEEE.
- [14] M.M Rashid, Nadhirah Mokhtaruddi, Md. Julkar Nayen. (2019, March). Development of a glucose sensor system with real time calibration *International Journal of Recent Technology and Engineering (IJRTE)* ISSN: 2277-3878, Volume-7, Issue-6S.