

Development of Automatic Litter Box Using ESP32

Muhammad Hazwan Zainal¹, Chua King Lee^{1*}

¹Faculty of Electrical and Electronic Engineering,
Universiti Tun Hussein Onn Malaysia, Parit Raja, Batu Pahat, 86400, MALAYSIA

*Corresponding Author Designation

DOI: <https://doi.org/10.30880/eeee.2023.04.02.065>

Received 03 July 2023; Accepted 31 August 2023; Available online 30 October 2023

Abstract: The necessity to filter the clumping litter itself is a filthy activity that can generate an unpleasant odour if left neglected in litter boxes. In response to the preceding remark, Smart Litter Box is a work that will aid pet owners in resolving the most common problem encountered while cleaning their pet. In this study, a litter box is created that can autonomously clean cat faeces and refill the sand dispenser. Passive Infrared Motion Sensor is used to detect cat movement when it is inside the litter box and also cat faeces. A servo motor is employed to release sand from the dispenser, controlled through the Blynk application. Stepper motor used to move the filter in forward and opposite direction to be able push cat faeces. The Automatic Litter Box achieved its intended success, smoothly completing the cleaning process in a modest 4 minutes to make cat poop itself inside litter box and then the filter will scoop the faeces until it falls to storage area. It also has an alerting system notification which notify through the phone by email application make pet owner ready to remove the faeces any time by connecting Wi-Fi. A noticeable relationship became evident between the quantity of cat faeces present in the litter box and the distance it could travel. As the amount of faeces increased, the litter box's ability to cover distance decreased, highlighting the influence of heavier loads on its mobility.

Keywords: Autonomous Cleaning, Sand Dispenser, Blynk

1. Introduction

Nowadays, with the change and development of the times, more young people live alone in cities, facing the pressures of work and often lacking companionship. In response to this, cats have emerged as a popular choice for pet companionship among young people [1]. Cats are known for their placid nature, enjoyment of order and cleanliness, and low maintenance requirements, making them convenient pets for busy individuals. As people's economic circumstances improve, more families can afford to raise cats. However, dealing with cat waste poses a challenge for many cat owners. To address this issue, innovative solutions have been developed to overcome the problems of conventional litter boxes. These advancements eliminate the need for pet owners to physically filter the faeces, providing a more convenient and hygienic approach to manage cat waste. With the combination of these factors,

*Corresponding author: chua@uthm.edu.my

2023 UTHM Publisher. All rights reserved.

publisher.uthm.edu.my/periodicals/index.php/eeee

the popularity of cats as companions among young people continues to rise, bringing comfort, stress relief, and entertainment to their lives.

One of the similar works is self-cleaning cat litter box which is to make self-cleaning cat litter boxes very economical to cat owners. Furthermore, with auto-bagging and IoT, this design could free people from the unpleasant task of cleaning the cat litter box. Contain feature an ATMEGA328P microcontroller from the Arduino board and an ESP8266 [8]. Its operations involve controlling the clean and bagging motor module, the cat detection module, and the user interface module for manual and remote control of the device. The filtering for this product was handled by a cart in the shape of a comb. One motor, which can move two folding arms along the sidewall of the box, drives the comb cart. Waste may be pushed and rubbish can be filtered by the cart that moves from one side to the other. At the back of the box is intended to be an open pouring space. These waste materials will be guided into the plastic bag by a pie with a funnel shape.

2. Materials and Methods

ESP32 is used to serve as a microcontroller for this work and also used with Blynk application which as Internet of Things (IoT) so that pet owner can receive a notification through their phone that makes pet owner ready to remove the faeces. This happened after Byj48 Stepper motor moves to push faeces after being triggered by Passive Infrared motion sensor. After that, Servo motor used to control open and close for sand dispenser by Blynk application. Light Emitting Diode (LED) used as indication for cat and the faeces motion.

Specifications and properties of materials, equipment, and other resources used in this work are described in this section.

- ESP32
- Passive Infrared motion sensor (PIR sensor)
- Byj48 Stepper motor
- Servo motor
- Light Emitting Diode (LED)

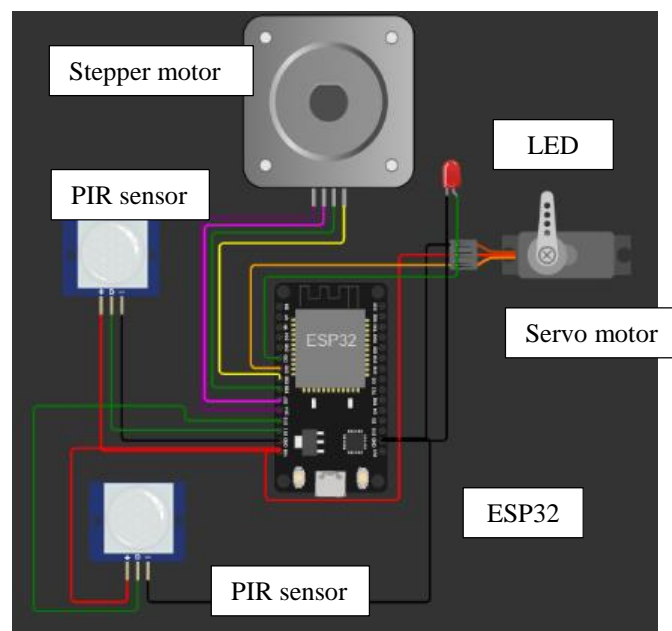

Figure 1: Schematic diagram for the system

Figure 1 shows schematic of an Automatic Litter Box System. This setup utilizes the ESP32 in collaboration with the Blynk application to develop IoT initiatives that encompass remote management of a sand dispenser using a Servo motor. Additionally, it offers notifications upon activation through a PIR sensor. An additional PIR sensor serves to identify cat motion within the litter box.

Figure 2 shows workflow of the work which the first step is identifying the problem for an automatic litter box involves recognizing the challenges and shortcomings associated with conventional litter boxes and manual maintenance. Then, a literature review involves examining existing research, studies, and technological solutions related to Automatic Litter Box systems. The methodology combines simulation and hardware testing to develop the automatic litter box system comprehensively. Simulation detects design flaws, while hardware testing validates real-world performance. Through an iterative process guided by simulation and testing, the end product is a reliable IoT solution meeting pets' owners need effectively. Analysing the performance of sensors, such as PIR sensors for detecting cat movement, involves understanding their accuracy, range, and response times. This examination ensures that sensor inputs are reliable and trigger the appropriate actions. Lastly, carry out with writing thesis by conclude the research.

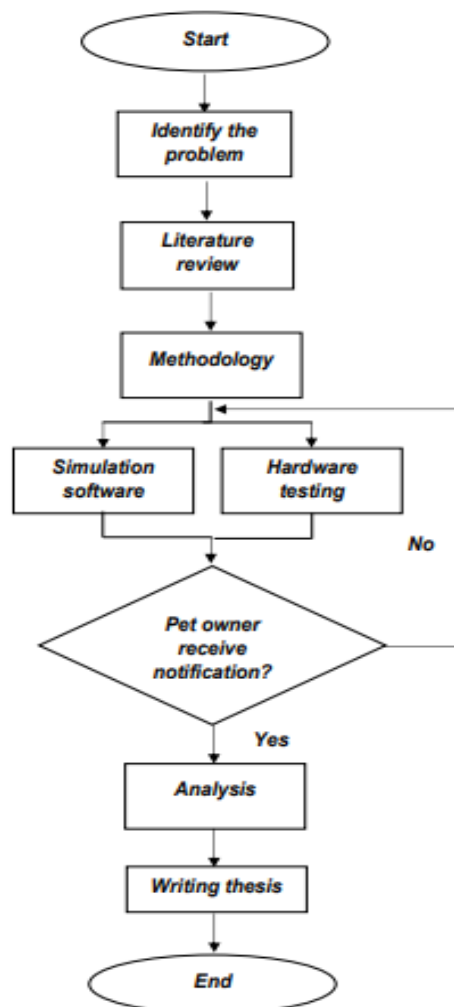

Figure 2: Flow of the work

Figure 3 shows the process of the proposed system which consists of PIR motion sensor to determine whether a cat is in the litter box. The cat should exit the litter box at the proper time, which is 4 minutes' delay. Additional PIR motion sensor is utilized to detect cat waste and notify a to Blynk email after faeces in the storage. At last, Servo motor is used to open and close sand dispenser.

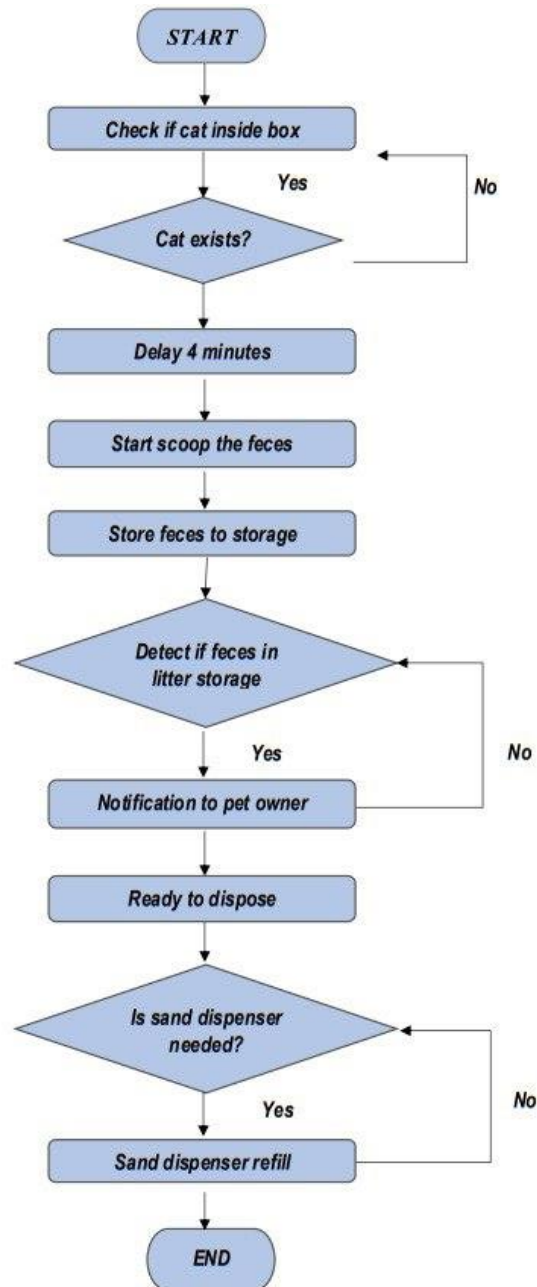

Figure 3: Process of the proposed system

Figure 4 shows a block diagram of Automatic Litter Box with two main sections connected to an Arduino which input and output. The input section employs a PIR motion sensor to detect cat presence and faeces. On the output side, a precise stepper motor and adaptable servo motor manage waste disposal and sand dispenser. The system also communicates notifications to external devices for real-time updates.

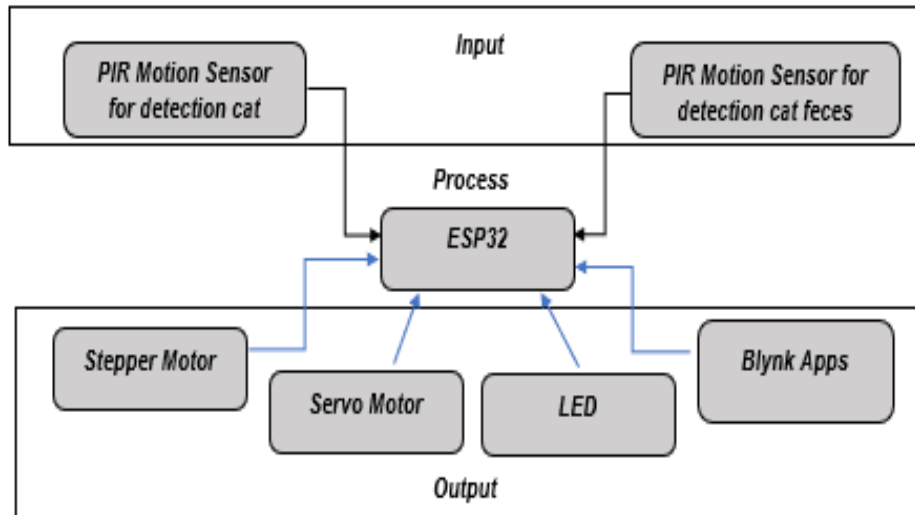

Figure 4: Block diagram

3. Results and Discussion

For this section, the system's outcome will be influenced by its ability to notify the pet owner about the need to eliminate the faeces through notifications. Additionally, this system enables remote control of the sand dispenser via a mobile device.

3.1 Blynk notification for pet owner

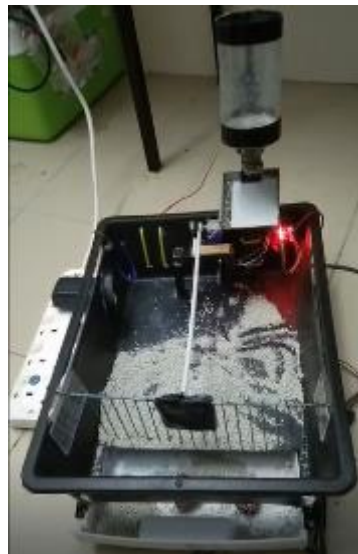

Figure 5: Filter push faeces into waste storage

Figure 5 shows the smart litter box system incorporates a filter mechanism that pushes the cat faeces towards a designated storage area. As part of the detection process, a PIR (Passive Infrared) motion sensor is employed to identify any movement indicating the falling of faeces into the storage compartment. The PIR sensor transmits this motion data wirelessly to the ESP32 microcontroller, which then triggers a notification to alert the user of the event.

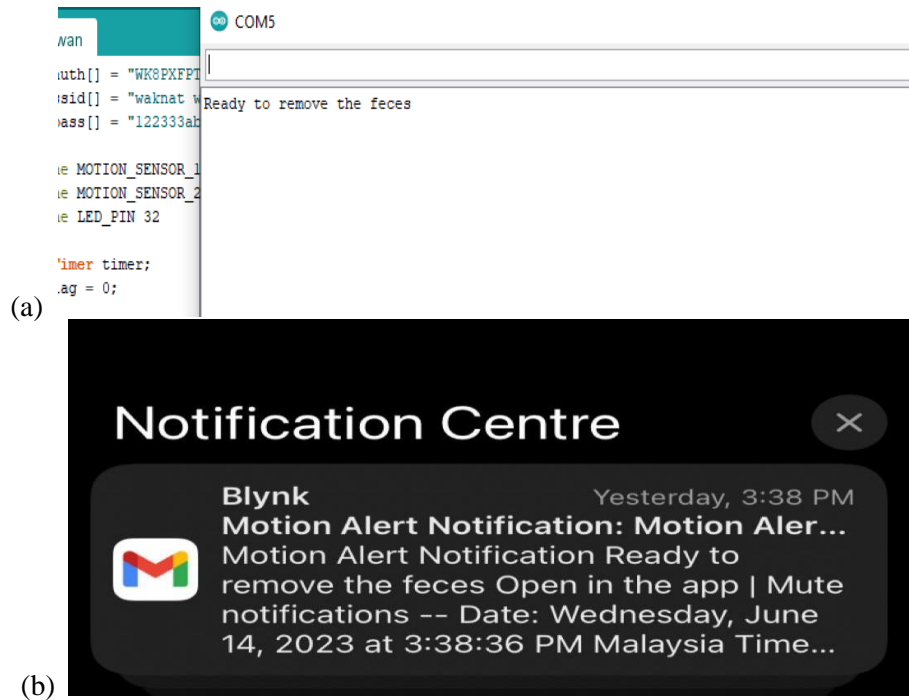

Figure 6: (a) Output serial monitor from COM5 (b) Notification from Blynk Email

Figure 6 shows the Serial monitor serves as a tool in the Arduino IDE that enables the visualization and analysis of data obtained from sensors or other input devices connected to the system. Upon modifying the code to include the message "Ready to remove the feces" and initiating the detection process with the PIR motion sensor, the output displayed in the Serial monitor confirms the detection of the cat's presence, indicated by the message "Ready to remove feces". This allows the pet owner to confidently monitor the litter box and promptly address any necessary maintenance tasks. Additionally, the output from the Serial monitor is sent to the Blynk app via Blynk Email, providing convenient notifications to the user, ensuring continuous monitoring and enabling effective management of the litter box system.

3.2 Control Servo motor by Blynk Apps

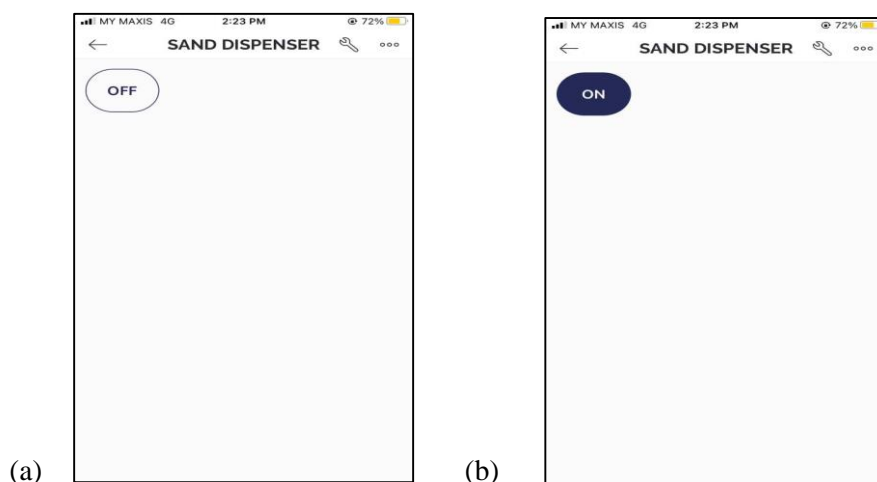

Figure 7: (a) Button OFF to make Servo Motor close (b) Button ON to make Servo Motor Open

Figure 7 shows the device from Blynk Apps will turn online after uploading the coding from Arduino IDE. After that, button ON and OFF can use to control Servo Motor to open and close for sand dispenser.

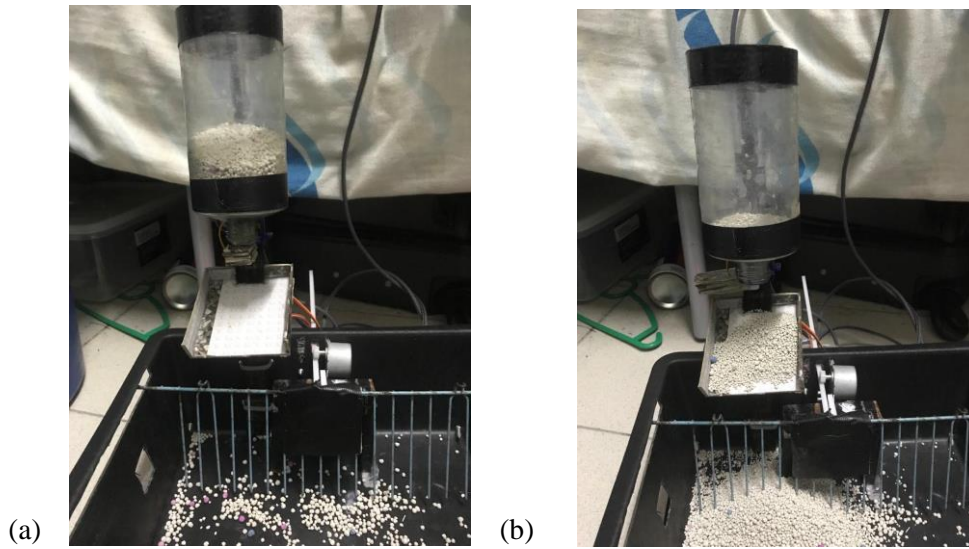

Figure 8: (a) Sand dispenser before ON Servo (b) Sand dispenser after ON Servo

Figure 8 shows the gradual decrease of sand from the dispenser, indicating the successful refill process in the litter box. This functionality simplifies the task of maintenance for pet owners, as they can easily observe when a refill is needed. By ensuring that the litter box remains properly filled, this feature promotes a clean and comfortable environment for the cats, contributing to their overall well-being.

3.3 Analysis

Figure 9 shows an analysis, test Run 6 (Distance: 2048 steps, Speed: 350 steps/s, Load: 60 grams) show an improvement in terms of performance in distance, speed, and load capacity compared to Test Run 1 (Distance: 1000 steps, Speed: 200 steps/s, Load: 50 grams). The smart litter box prototype demonstrated the ability to cover a longer distance, operate at a faster speed, and accommodate a higher load of cat faeces in Test Run 6. These findings suggest that the prototype has the potential to effectively handle greater demands and improve waste management efficiency.

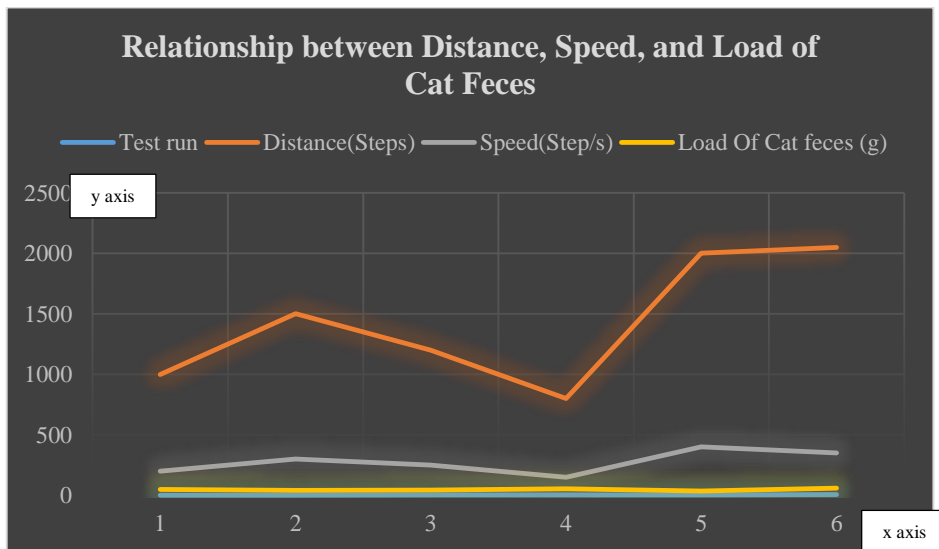

Figure 9: Analysis result

4. Conclusion

The work has successfully achieved the aim and the automatic feature on the litter box will make it easier for pet owners to clean their litter box without investing their energy and time. It is proven that when compared to the conventional litter box, the process would save a significant amount of time and energy. Also, the integration of the ESP32 microcontroller allows users to remotely monitor and control the litter box via a smartphone application. This feature provides convenience, flexibility, and peace of mind to pet owners, especially when they are away from home or have busy schedules.

Acknowledgement

The authors would like to thank the Faculty of Electrical and Electronic Engineering, Universiti Tun Hussein Onn Malaysia for its support.

References

- [1] S. Subaashri, M. Sowndarya, D.K.S. Sowmiyalaxmi, S.V. Sivassan and C. Rajasekaran, "Automatic Pet Monitoring and Feeding System Using IoT", *International Journal of ChemTech Research*, vol. 10, no. 14, pp. 253-258, 2017
- [2] S. F. Vaughn, M. A. Berhowa, J. K. Winkler-Mosera and E. Leeb, "Formulation of a biodegradable odor-reducing Cat Litter from solvent-extracted corn dried distillers' grains", *Industrial Crops and Products*, vol. 34, no. 1, pp. 999-1002, 2011.
- [3] J. J. McGlone, A. Garcia, W. G. Thompson and G. M. Pirner, "Maternal-neonatal pheromone/interomone added to cat litter improves litter box use and reduces aggression in pair-housed cats", *Journal of Applied Animal Welfare Science*, vol. 22, no. 2, pp. 127-138, 2019.
- [4] Jaycon Systems, & Instructables. (2017, September 30). Getting started with the ESP8266 ESP-01. Instructables. <https://www.instructables.com/Getting-Started-With-the-ESP8266-ESP-01/>
- [5] Lady Ada [20190. PIR Motion Sensor. Pyroelectric ("Passive") InfraRed Sensors. Retrieved from <https://learn.adafruit.com/pir-passive-infraredproximity-motion-sensor>
- [6] Cathleen Shamieh (2016, August 30). Become Familiar with LEDs. *Electronics For Kids For Dummies*. Retrieved from <https://www.dummies.com/article/technology/electronics/generalelectronics/become-familiar-leds-223>
- [7] Teel, J. (2022, November 10). Introduction to the ESP32 WIFI / bluetooth wireless microcontroller. *PREDICTABLE DESIGNS*
- [8] Self-cleaning cat litter box - University of Illinois Urbana-Champaign. (n.d.). Retrieved January 19, 2023, from <https://courses.engr.illinois.edu/ece445/getfile.asp?id=19195>
- [9] Liu Guoan. Design and research of household cat poop cleaner[D]. Tianjin University, 2013.
- [10] Ellrich, B. (2023, August 11). Automatic Litter Boxes: Simplifying Cat Care. *Cattitude Daily*. <https://cattitudedaily.com/automatic-litter-boxes-simplifying-cat-care/>
- [11] Chillx.co, "Chillx autoegg self-cleaning litter box," Online, accessed: 17-Feb-2021. [Online]. Available: <https://chillx.co/products/chillx-autoegg-self-cleaning-litter-box-1-modern?variant=32121145229361>