

## MRAC Control for Temperature Regulation of Dodol Processes

Imran Muhamad Ghazali<sup>1</sup>, Rohaiza Hamdan<sup>1\*</sup>, Mohd Hafiz A. Jalil<sup>1</sup>

<sup>1</sup>Faculty of Electrical and Electronic Engineering,  
Universiti Tun Hussein Onn Malaysia, Batu Pahat, 86400, MALAYSIA

\*Corresponding Author Designation

DOI: <https://doi.org/10.30880/eeee.2023.04.01.083>

Received 16 January 2023; Accepted 06 February 2023; Available online 30 April 2023

**Abstract:** Dodol is a traditional Malaysian cuisine that have a sticky consistency and sweet flavour. In order to cook it a person need to control the temperature of fire to make sure the dodol is not burnt and have the correct consistency. Adaptive control has long been yearned to be implemented on control systems. With the implementation of adaptive control, a system can regulate itself without any assistance from an operator or user. Besides that, it functions using a closed loop system and the system can regulate itself with the designated input and output. The system will trace back and feedback the signal if there is any error detected and will compare it to the reference model until there is no error so the system will maintain almost perfect efficiency when operating. In this project Model Reference Adaptive Control (MRAC) is implemented into a dodol making machine for temperature regulation. The transfer function from the dodol plant is modeled using Autoregressive Exogenous Variables (ARX) method using System Identification Toolbox. The performance of MRAC system is analysed and compared to Proportional Integral Derivative (PID) controller to see which controller is better in terms of rise time, settling time and overshoot value. Based on the comparative study done, the MRAC controller has better rise time, settling time and overshoot value compared to PID controller which are 207.784s, 561.412s, 0.500% and 334.933s, 1606.311s, 4.737% respectively for each controller. Overall, the MRAC controller is proven stable and can be proceeded with real time testing.

**Keywords:** MRAC, PID, ARX, Dodol, Temperature Regulation

### 1. Introduction

Traditional dodol preparation takes a lot of effort, time, and fresh ingredients. To generate the perfect texture and flavour of the dodol, it also takes painstaking labour, talent, and the right method [1]. The traditional way of cooking dodol requires too much manual labors and energy so to make it easier the idea of using Model Reference Adaptive Control (MRAC) control for temperature regulation is proposed.

Modern industry makes extensive use of modern controllers to enhance system performance while raising production rates, preserving product quality, and meeting safety requirements. Advanced controllers come in a variety of forms, such as the adaptive controller. One of the most well-liked adaptive controllers, MRAC, is frequently employed in control systems that contain unknown dynamic, parameter fluctuation, or change over time. Due to the special properties of MRAC, it is possible to specify desired performance in terms of a reference model, with the controller being continually changed to ensure that the system output provides the required response to a command signal [2]. By modifying the reference model to acquire either rapid or slow transient output, this capability enables designers to easily establish the appropriate transient performance. MRAC has been utilised in several processes, such as temperature control, and has emerged as a possible controller for resolving industrial problems [3]. After considering the advantages of MRAC, the MRAC is used as temperature regulation in dodol making processes.

The conventional way of making dodol uses many people to observe the dodol to make sure it is evenly stirred and get the right consistency while watching the temperature to make sure it the dodol doesn't end up burnt or too hard. The implementation of MRAC control will help make the process of making dodol more precise with the correct temperature regulation as it will control the heat if it's too high or too low. This project will focus on the design of MRAC temperature control in MATLAB SIMULINK, creating a mathematical model for the circuit and analyzing the performance of MRAC and comparing it with PID controller for temperature regulation of dodol plant.

## 2. Methodology

This project deals with the modeling of MRAC temperature regulation for dodol making process. The transfer function is obtained using Autoregressive Exogenous Variables (ARX) method from the system identification toolbox. To simulate the model MATLAB Simulink is used to obtain the mathematical model and a waveform of MRAC compared to the reference signal. The parameter that is being controlled is the temperature and valve opening. The process of taking the dodol temperature and how the transfer function of MRAC is obtained is also explained. Figure 1 shows the flowchart for this project.

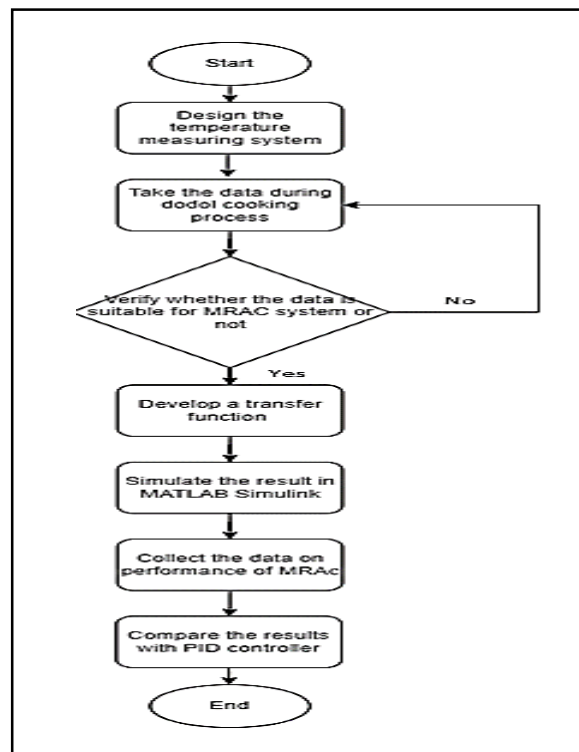

Figure 1: Project flowchart

## 2.1 Data Collection

Figure 2 shows the structure of the system that is used to measure the temperature of dodol for processing plant. For the input of the system the usage of infrared temperature sensor is proposed. The sensor is connected to Arduino UNO board to be controlled and purposed to take the measurement of temperature while cooking dodol. A valve is used to control the volume of gas that is going into the fire pit and is set to 60% opening. Finally, the Arduino board will be connected to a laptop as a display for the measurement of temperature for dodol cooking process. It will display the temperature during cooking process of dodol in two seconds interval so we can collect the data and create a transfer function for MRAC system.

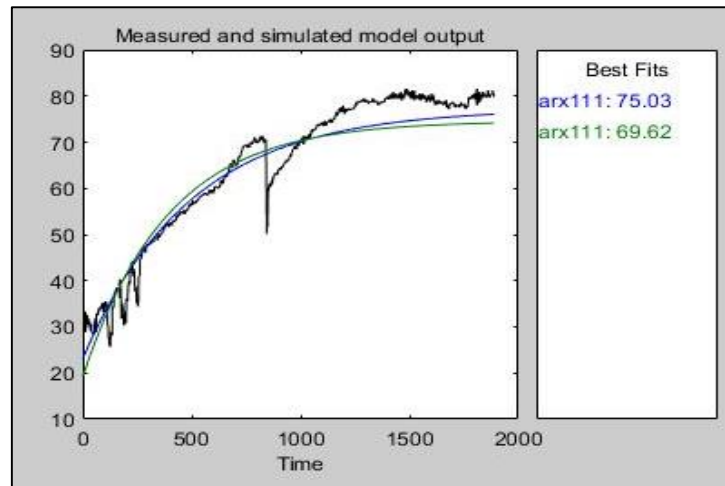

**Figure 2: Data collection system**

## 2.2 System Modelling

One of the most basic models for the general linear model structure of a black box model is the ARX model. An autoregressive model is one in which the output variable exhibits linear dependence on both its own historical values and a randomly chosen term. The ARX model was selected for this study's development out of a few simpler models [4]. The data is split into even and odd data for the model validation and based on the input and output data a transfer function in the first order is generated by using System Identification Toolbox in MATLAB Simulink software. The transfer function obtained from the modelling is shown in Eq 1. Then Figure 3 shows the best fits of the validated data which have 75.03% for the odd data while the even data have 69.62% so the odd data is used as a model for the transfer function.

$$G(s) = \frac{0.2616}{s+0.002002} \quad \text{Eq.1}$$



**Figure 3: Best fits for transfer function modelling**

### 2.3 MRAC Circuit

MRAC is made up of and consists of 3 main components which are the plant, reference model and adjustment/adaptation mechanism. The plant is used to provide the transfer function for the entirety of the MRAC system to be based on. The reference model provides a reference against which the output is compared. Finally, the adjustment/adaptation mechanism, a component that is used to change the controller's settings so that the actual plant can follow the reference model. The adjusting mechanism may be created using mathematical techniques such as the MIT rule, Lyapunov theory, and theory of augmented error [5]-[7]. Figure 4 shows the circuit of MRAC system using MIT rule for dodol process.

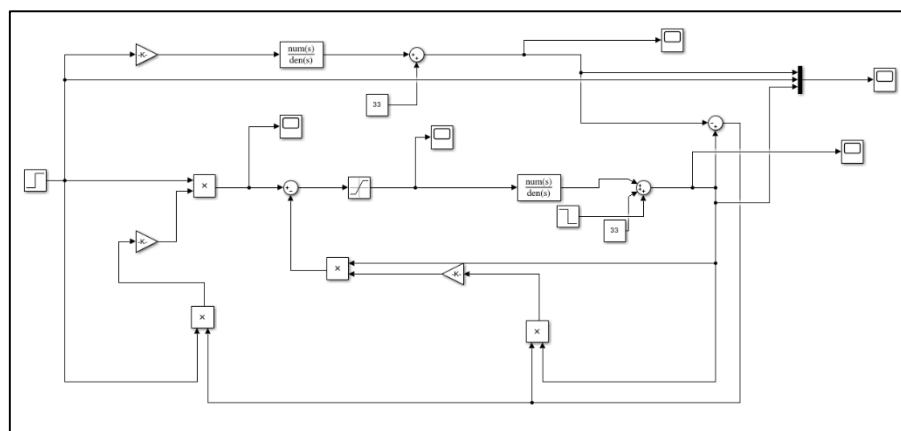

**Figure 4: MRAC simulation circuit for dodol process**

### 2.4 Reference Model

The reference for this system has been designed based on the output data used for the plant modelling. The reference model used for this system design is shown in Eq 2.

$$G(s) = \frac{1}{100s+1} \quad \text{Eq.2}$$

### 2.5 Proportional Integral Derivative (PID) Design

The values of  $K_p$ ,  $K_i$ , and  $K_d$  are necessary while developing the PID controller. Ziegler Nichols and Cohen Coon tuning rules are two tuning techniques. The process gains  $K$ , time delay, and time constant for the system will be calculated from the open loop response using the process reaction curve

approach [8]. Table 1 shows the values of gain  $K_p$ ,  $K_i$  and  $K_d$  using Ziegler Nichols method and Figure 5 shows the PID circuit used for the simulation.

**Table 1: Values of PID controller gains**

$K_p$	$K_i$	$K_d$
0.0190	6.2892	0.5849

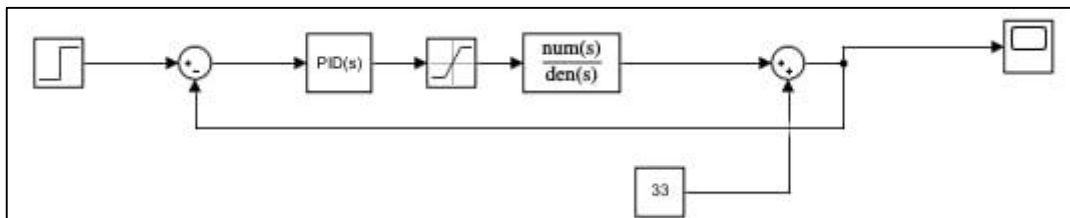

**Figure 5: PID circuit used for simulation.**

### 2.6 Performance Analysis

The performance of the MRAC controller is analysed in terms of rise time, settling time and overshoot. The rise time is obtained from the step response when the waveform increases from 10 to 90 per cent of its steady state. The settling time is obtained when the waveform is close or between a given error band in the response and remain there over a period of time. Overshoot is the value when there is a time that the waveform exceeds and goes beyond the set point, the percentage of the waveform that exceeds the set value is known as percentage overshoot. These parameters are important to determine the stability of the system. A system with fast rise time and better settling time is good as it reaches the steady state faster.

## 3. Results and Discussion

The results and outcomes of this project is explained and discussed in this section. All the performance for MRAC and PID controller, results and simulations are performed in MATLAB Simulink.

### 3.1 PID Controller Performance

Table 2 shows the response of PID controller. The step response waveform for PID controller has a rise time of 334.933s, settling time of 1606.311s and overshoot of 4.737%. The response of PID controller is stable. The performance of PID controller for dodol process is shown in Figure 6.

**Table 2: PID controller step response**

Rise Time (s)	Settling Time (s)	Overshoot (%)
334.933	1606.311	4.737

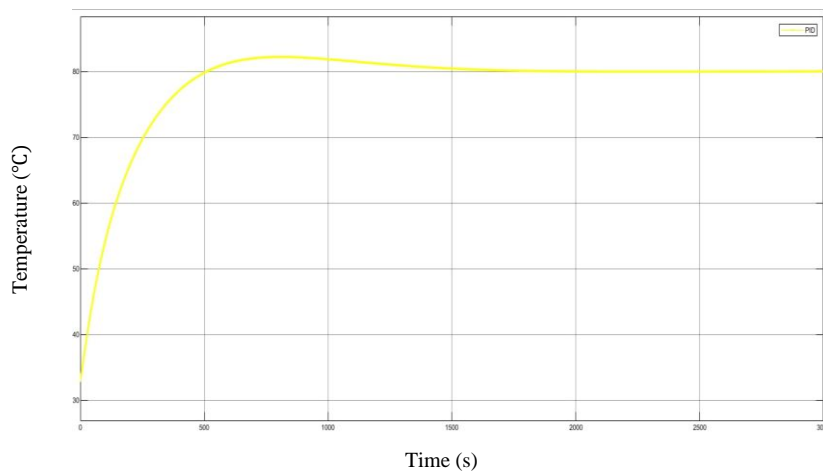

**Figure 6: PID controller performance in dodol cooking process.**

### 3.2 MRAC Performance

The ideal performance of MRAC is obtained by trial-and-error method using several different tests for the negative and positive gain of the system to see the effect on the response waveform. Table 3 shows the test results of different gains used and its effect on response. Result from test 5 was decided to be the ideal performance of MRAC. Figure 7 shows the ideal performance of MRAC for dodol cooking process. During the cooking process of dodol there is a disturbance when brown sugar is added to the dodol mixture. There is a drop in temperature during the time so to simulate this a disturbance is added to simulate the temperature drop. Figure 8 shows the ideal performance with disturbance.

**Table 3: MRAC performance with different test of adaptation gain**

Test	$-\gamma_1$	$+\gamma_2$	Rise Time (s)	Settling Time (s)	Overshoot (%)
1	-2E-4	32E-5	150.940	422.147	28.68
2	-4E-7	65E-7	419.916	903.772	0.505
3	-4E-6	65E-6	237.290	632.495	7.491
4	-4E-4	65E-4	381.640	900.870	20.816
5	-5E-4	3E-4	207.784	561.412	0.500

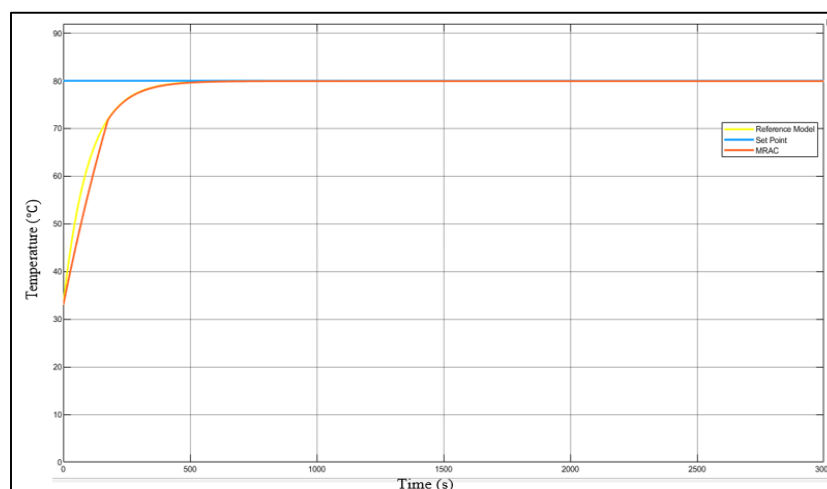

**Figure 7: Ideal performance of MRAC for dodol cooking process.**

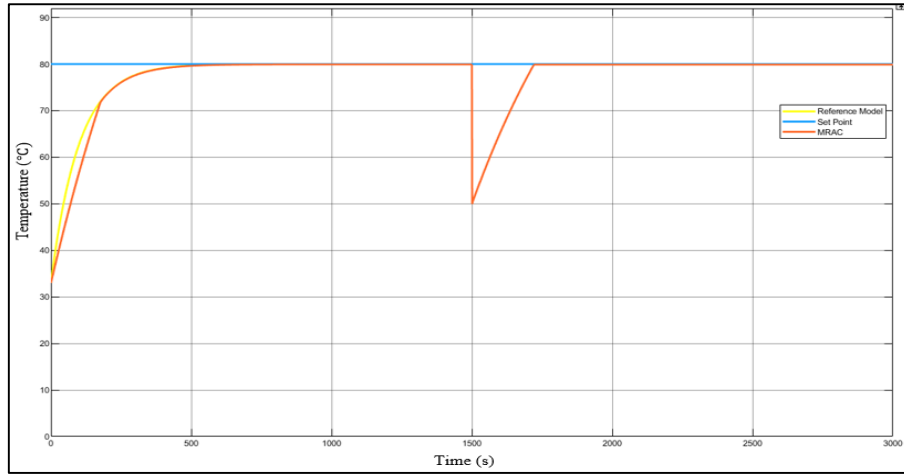

**Figure 8: Ideal performance of MRAC for dodol cooking process with disturbance.**

### 3.3 Comparative Analysis

The comparison between the performance of MRAC and PID controller is done based on the value of rise time, settling time and overshoot percentage. Each controller is set to reach the optimal temperature for cooking dodol which is 80°C. The time taken for PID controller to reach the set point and maintain a stable performance is longer compared to MRAC. The rise time and overshoot value for PID controller is also longer compared to the MRAC. Figure 9 shows the performance of the controllers to reach the set point. The performance of the MRAC and PID controller is shown in Table 4.

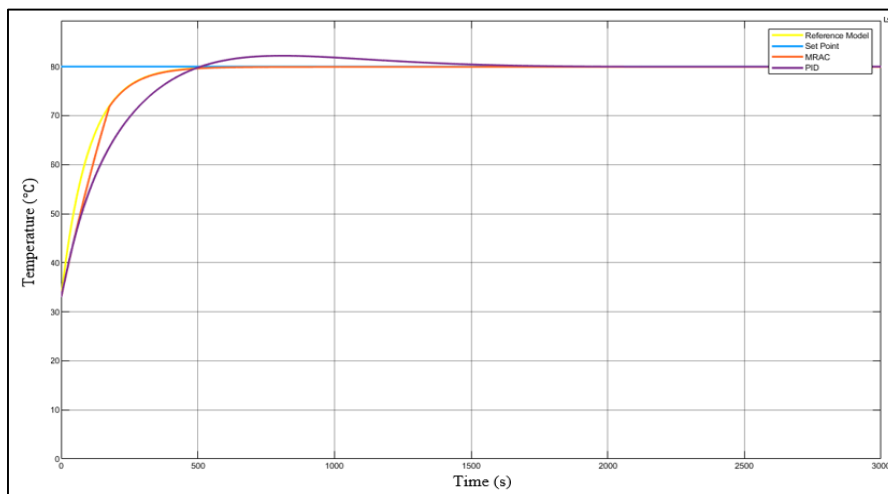

**Figure 9: MRAC and PID response for dodol cooking process.**

**Table 4: Performance of MRAC and PID controller**

Type of Controller	Rise Time (s)	Settling Time (s)	Overshoot (%)
MRAC	207.784	561.412	0.500
PID	334.933	1606.311	4.737

After analysing the result from Figure 9 and Table 4 for the comparison between the performance of the controllers MRAC and PID, the values of rise time 207.784s, settling time 561.412s and overshoot 0.500% are obtained for MRAC controller. Meanwhile, the PID

controller has a rise time of 334.933s, settling time 1606.311s and overshoot 4.737%. First, the rise time of MRAC is slightly faster compared to the rise time of PID controller with a difference of 127.149 seconds. Then, there is the settling time of the controllers, the settling time of MRAC is also faster than PID with difference of 1044.899 seconds. Lastly, the overshoots of the controller which have the MRAC with only 0.500% overshoot compared to the PID with an overshoot of 4.737%. Overall MRAC is the better controller as it will reach the set point and reach steady state faster. The overshoot value of MRAC is also better with just a slight difference in the temperature spike. Both controllers show a stable system response but in terms of performance MRAC is better.

#### 4. Conclusion

The comparative analysis concluded that MRAC controller is better because of its fast response time and reaches steady state faster compared to PID controller. The simulation also shows that the response is stable and can be proceeded with real time and contribute to increasing the effectiveness for dodol cooking process.

#### Acknowledgment

The authors would also like to thank the Faculty of Electrical and Electronic Engineering, University Tun Hussein Onn Malaysia for its support.

#### References

- [1] Ismail, N., Ab. Karim, M.S., Che Ishak, F.A. *et al.* The Malay's traditional sweet, *dodol*: a review of the Malaysia's heritage delicacy alongside with the rendition of neighbouring countries. *J. Ethn. Food* 8, 19 (2021). <https://doi.org/10.1186/s42779-021-00095-3>
- [2] C.-C. Hang and P. C. Parks. 1973. Comparative Studies of Model Reference Adaptive Control Systems. *IEEE Transactions on Automatic Control*. Vol. 18, No. 5, pp. 419-428.
- [3] Jiraphon S. and Supot P. 2010. Model reference adaptive temperature control of the electromagnetic oven process in manufacturing Process. In: *WSEAS International Conference on Signal Processing, Robotics and Automation*. pp. 57-61.
- [4] S. Rachad, B. Nsiri, and B. Bensassi, "System Identification of Inventory System Using ARX and ARMAX Models," vol. 8, no. 12, pp. 283–294, 2015.
- [5] P. Jain and M.J. Nigam, "Design of a Model Reference Adaptive Controller Using Modified MIT Rule for a Second Order System", *Advance in Electronic and Electric Engineering*, Vol. 3, No. 4, pp. 477-484, 2013
- [6] S.G. Anavatti, F. Santoso and M.A. Garrat, "Progress in Adaptive Control System: Past, Present and Future", presented at International Conference on Advanced Mechatronics, Intelligent Manufacture, and Industrial Automation, Surabaya, Indonesia, October 15-16, 2015.
- [7] P.A. Ioannou and J. Sunn, *Robust Adaptive Control*, Los Angeles, CA: Pearson Education Inc., pp. 23-25, 2003.
- [8] B. Copeland, "The Design of PID Controllers using Ziegler Nichols Tuning"