



Laser Technology Applications in Critical Sectors: Military and Medical

Suratun Nafisah¹, Zarina Tukiran^{2,3*}, Lau Wei Sheng³, Siti Nabilah Rohim³, Vincent Sia Ing Teck³, Nur Liyana Razali^{2,3}, Marlia Morsin^{2,3*}

¹Department of Electrical Engineering,
Institut Teknologi Sumatera (ITERA), Lampung Selatan, 35365, INDONESIA

²Microelectronics and Nanotechnology – Shamsuddin Research Centre, Institute for Integrated Engineering,
Universiti Tun Hussein Onn Malaysia, Parit Raja, Batu Pahat, 86400, Johor, MALAYSIA

³Department of Electronic Engineering, Faculty of Electrical and Electronic Engineering,
Universiti Tun Hussein Onn Malaysia, Parit Raja, Batu Pahat, 86400, Johor, MALAYSIA

*Corresponding Author

DOI: <https://doi.org/10.30880/jeva.2021.02.01.005>

Received 29 March 2021; Accepted 23 May 2021; Available online 30 June 2021

Abstract: This study aims to observe laser technology applications in two critical sectors which are military and medical. These two crucial sectors required a technology that is compatible with the nature of the field; safe, precise and fast (time –saving). A laser is defined as a device that emits a focused beam of light by stimulating the emission of electromagnetic radiation. The characteristics of lasers; coherence, directionality, monochromatic and high intensity are very suitable to be used in the critical sectors. In the military sector, the implementation of laser is commonly used in various types of weapons manufacturing. In this paper, three different military weapon systems namely weapon simulator, laser anti-missile system and navy ship laser weapon system were studied. Meanwhile, in the medical sector, the laser is widely implemented in medical equipment especially in dentistry, surgery and skin treatment. The capability of laser technology to be adapted in the critical sectors can be further investigated and enhanced for future discovery.

Keywords: Laser technology, laser weapon system, military sector, medical sector

1. Introduction

Laser, which is an acronym, stands for “Light Amplification by Stimulated Emission of Radiation” is a device that produces a powerful beam of light by stimulating the emission of electromagnetic radiation. To explain stimulated emission in detail; firstly, the laser device creates and amplifies a focused beam of light whose photons are coherent. Then, within a laser device, the lasing medium being crystals, gas or liquid is “pumped”, so the atom or molecules are excited to achieve a high energy level. Lastly, the atoms or molecules will be discharged to the form of a beam of light [1] as shown in Fig. 1. Before the invention of the laser device in 1960, Albert Einstein was the credited researcher that gave birth the concept idea on the quantum theory of radiation in 1917.

In addition, before laser, maser was developed earlier than the laser by Charles Townes, James P. Gordon and Herbert J. Zeiger [2]. The main difference between the two is; maser output is in the form of microwave, while the laser is in the form of visible light. However, the shortcomings of masers at the time are; firstly, the useful solid-state maser

*Corresponding author: zarin@uthm.edu.my

needs to operate at a very low temperature which is liquid helium temperature (4 Kelvins). Secondly, the maser uses a huge magnet, as much as 2 tonnes. Hence, in 1960, Theodore Maiman successfully developed the ruby laser as shown in Fig. 2. Since then, many types of lasers were continuously developed, using different lasing mediums, but still revolves around the concept of stimulated emission of light.

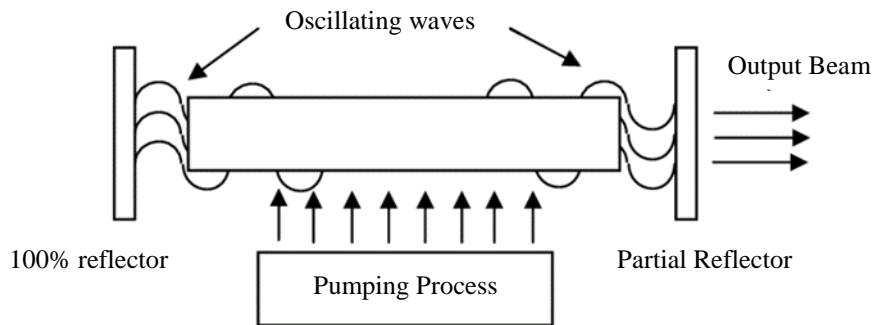

Fig. 1 - Diagram of laser system operation [3]

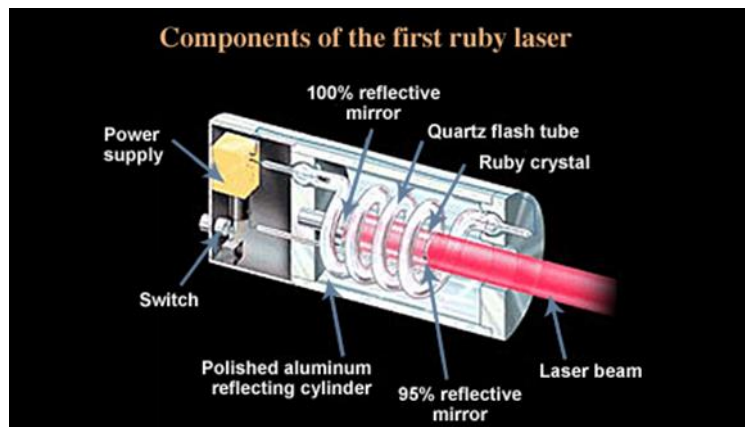

Fig. 2 - Diagram of ruby laser developed by Maiman [4]

Laser technology has been widely used in various types of sectors due to its capability and special characteristics. In non-critical sectors, for example in the apparel or clothing industry, the laser is very useful for cutting, engraving and fault detection of clothing products. In several garment factories, cloth manufacturing units, other clothing and leather industries, laser graving and cutting tools have been used extensively. For fault detection in the cloth, laser-based optical detection Fourier transforms can be used as the pattern replicates daily. A laser focuses on the textile and superimposes diffraction gratings from the periodicity of transverse and longitudinal threads in the textile. When the calculated parameter deviates from the norm, a fault is reported. Next, the laser cutting process produces well-finished edges in synthetic textiles, as the laser melts and fuses an edge that prevents conventional knife cutters from fraying. In some situations, sealing edges of cut patterns and sewn garment pieces is required to prevent fraying where the laser plays the role. Quick operation and cutting of textile textiles, composites and lateral materials were fitted with laser cutting machines [5]. In addition, the seam pucker has a laser beam to test the amount of geometry in clothing. In this process, by placing the garment on a dummy, a seam in the garment is scanned by a 3D laser scanner. An operator could move the laser head in a confined area to any 3D space. The pucker profile of the scanned seam can be achieved through image processing using a 2D optical philtre. The pucker profile can be used to obtain physical parameters such as $\log \sigma^2$ (σ is variance), which can then be connected linearly to the seam pucker grade. The pucker rating can be calculated objectively from the objectively measured $\log \sigma^2$. Next, laser scanning equipment uses one or two thin stripe lasers to determine body size. Cameras are also used to film the scene and support the laser scanner. More optical components can be used to sustain a single laser beam, like mirrors. For digitization, the human body relies on a laser scans computer (Fig. 3) comprised of light sensors and optical systems. The number of light sensors and optical systems may differ according to the position of the body.

In laser fading, the laser beam is applied to the material by a device to mark or fade. The hue is broken down with a laser beam and the vapours are loosened out. The material fades only where the fabric is impacted by the spotlight. Two types of lasers are used commercially which are solid based ($1 \mu m$ wavelength) and gas-based ($10 \mu m$ wavelength). The optimal fading degree depends on the wavelength, density of power and size of the beam. Compared to acid washes, the process of laser labelling or deterioration is more environmentally sound [6]. Lasers are also used in

laser engraving to mark or engrave an item. The method is very complex, and the laser head is mostly operated by computerised systems [6]. Clean, crisp and permanent are the marks created by laser engraving. In comparison lasers are faster than other conventional materials imprinting processes, allowing for a more versatile content range. In addition, laser gravure is used for printer gravure, hollowing, pattern gravure, leather gravure, denim etc. (Fig. 4). There are several other laser technologies in the textile industry that are used for laser treatment for durable antibacterial properties on silver nanoparticles used in the cotton industry [7]. Laser technology is gaining traction without any wet processing in garment finishing that can produce different surface ornaments. This approach is very precise and can run rapidly with strong repeatability and reproducibility [8].

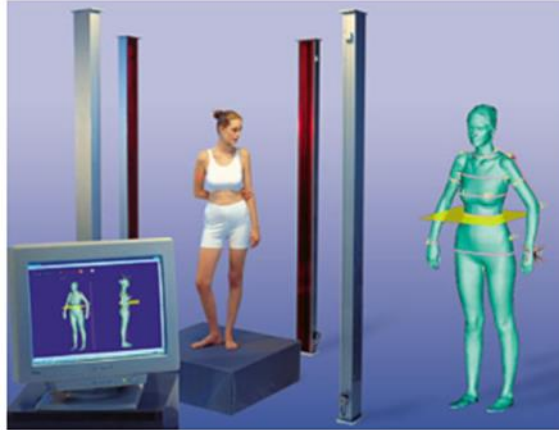

Fig. 3 - 3D body scanning by laser scanner [9]

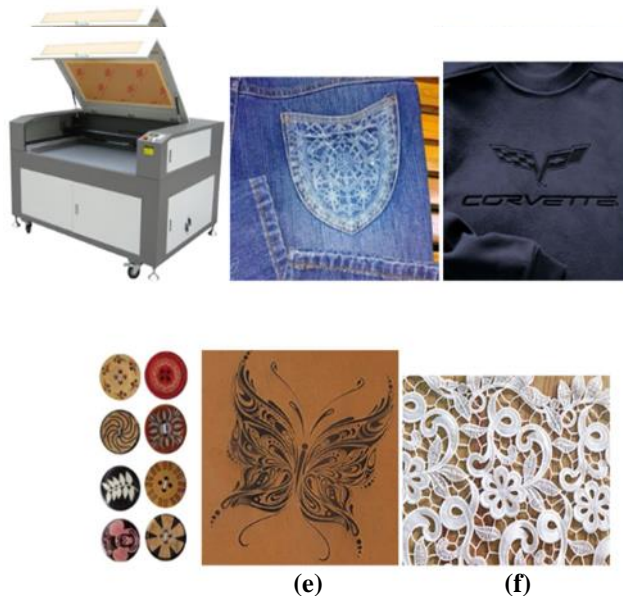

Fig. 4 - Laser engraving items (a) engraving machine; (b) denim; (c) garment; (d) buttons; (e) leather; (f) embroidery [10]

For a simpler application of laser such as bar code scanners (Fig. 5), helium-neon (He-Ne) laser are typically used to classify a product. When scanning the code, a revolving reflected laser beam bounces out. This sends a modulated beam containing commodity data to the computer. For this reason, semiconductor-based lasers can also be used. However, some recent producers are using RFID tags instead of barcodes because of those advantages. The RFID tag can be quickly processed and avoids physical handling of the label, as in bar code schemes [11].

Besides that, the laser is particularly useful for welding. Traditional welding can be risky for the welder and time-consuming; hence the laser welding technology is more preferable because of its safe and fast technology. Besides, the laser can be used as a measuring tool for bulkier and heavier materials such as steel. Using physical measuring tools to measure materials like steel can take up too much time, thus using a laser can be a much better alternative to gauge the physical dimensions of the material. Therefore, the capability of laser technology that offers efficient, time-saving and

safe technology with good repeatability and reproducibility was preferred to be implemented in critical and crucial sectors.

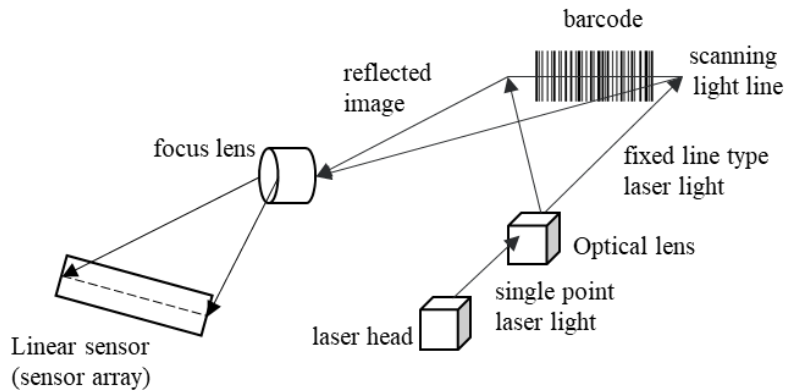

Fig. 5 - A laser barcode scanner [11]

In this paper, the application of laser technology in two critical sectors; military and medical; are discussed. In the military application, the laser is used for simulation and training purposes for soldiers to practise shooting, instead of using live bullets. Lasers can also be used as weapons of a defence system, either for anti-missiles or navy ships. The lasers are extremely precise and responsive, which can be used to target fast travelling airborne missiles, or to neutralize agile and smaller boats. The laser in military application emphasizes destructive power, accuracy and power efficiency.

In the medical sectors, lasers are widely used for different purposes. In this paper, the review is focused on the implementation of laser in dentistry, dermatology and ophthalmology. Laser in dentistry can be used for surgical means which is more precise and time consuming compared to the traditional hands-on method. Since lasers can also be modified in terms of wavelength, lasers can be used to target different layers of human skin, as a different wavelength of lasers penetrates different layers of skin. This makes lasers ideal for dermatological treatment purposes, either to treat skin illness or for cosmetics. Lastly, lasers are also commonly used in eye surgery to treat short-sightedness, far-sightedness and others. Lasers in the medical sector are unlike military application as it does not emphasize destructive power, but accuracy and precision are extremely important to prevent hurting the patient under treatment.

Table 1 - Timeline of Laser Technology Development

Year	Description
1917	Albert Einstein’s paper predicted the fundamental concept of laser, which is the “Stimulated Emission” phenomenon. This study is also based on Max Planck’s findings [13].
1953	Charles Townes develops the maser, which uses the stimulated emission concept on microwaves. Received a Nobel Prize in Physics in 1964 [14].
1960	The first ruby laser was constructed by Theodore H. Maiman [15].
1961	The first medical treatment using a laser was performed successfully to remove the retinal tumour by Dr. Charles J. Campbell [16].
1962	The Gallium Arsenide Phosphide laser diode was developed by Nick Holonyak Jr., which becomes the foundation of red LEDs used in modern-day DVD players, cell phones, etc. [17].
1964	The carbon dioxide laser was invented by C. Kumar N. Patel, which is used widely in the present day as a precision cutting tool in the medical and manufacturing sector [18].
1971	The first semiconductor which operates at room temperature was developed by Izuo Hayashi and Morton Panish from Bell Labs [19].
2003	A team of researcher from NASA successfully flies the first laser-powered aircraft. The laser is fired from the ground to the photovoltaic cells which power the propeller of the airborne aircraft [20].
2009	Intel announces the application of Light Peak optical fibre technology which uses vertical-cavity surface-emitting lasers (VCSELs) for household personal computers. This technology enables the sending of receiving of 10 billion bits of data per second [21].
2017	A group of researcher develops a laser using fluorescent protein extracted from a jellyfish. This type of laser is compatible with and can be implanted in living organisms [22].

2. Laser Development Timeline

Table 1 shows the timeline on the beginning of laser technology and how it changes over the years [12]. The historical events chosen are to show how the laser grows from an idea to reality, and how improvements are made to make laser technology as it is today.

The development of laser technology has never stopped and is predicted to continuously grow. In fact, the laser technology market prediction by Markets and Markets Research states that the laser technology market size will grow from 11.7 billion US\$ in the year 2020 to 17.6 billion US\$ in the year 2025 [23].

3. Applications of Laser Technology in Critical Sectors

In this section, the applications of laser technology in the military and medical sectors are discussed.

3.1 Laser Technology in Military Application

The laser technology used in the three different military weapon systems namely weapon simulator, laser anti-missile system and navy ship laser weapon system are studied.

(a) Laser Weapon Simulator

This patent was created by Richard A. Dye and Donald A. Rowley to invent a laser weapon simulator for soldiers to train marksmanship in 1976 [24]. The laser system uses semiconductor Gallium Arsenic (GaAs) lasers. GaAs semiconductors can function at high frequency and are not sensitive to heat. This laser weapon simulator will be attached to a barrel of a weapon to be used which in this case of study, is an M-16 rifle. This technology is expected to replace real bullets used for training, which in turn saves cost and increases safety for training since the drawbacks of using real bullets for marksmanship training is the cost of bullets, the wear-and-tear of the insides of the rifle, and the risk of misfiring that may cause physical harm.

Fig. 6 shows an M-16 rifle (10) with the laser weapon simulator device (11). Despite using a real functional weapon, the cartridge on the weapon should be blank, which means no bullets should be used. To explain the operation of the laser weapon simulator, in short, the laser weapon simulator involves a laser transmitter circuit (17) which is powered by the excitation of a piezoelectric crystal (16). A piezoelectric material is a material that produces an electric current under mechanical stress. The mechanical stress in this case is the pulling of the trigger. When the trigger of the weapon (10) is pulled, an external battery will power the laser transmitter, resulting in the firing of laser "bullets" (12), which is a laser pulse. Then, the infrared detector on the target will display the results on where the "bullets" land on the target. The cross-sectional diagram of the laser weapon simulator is shown in Fig. 7.

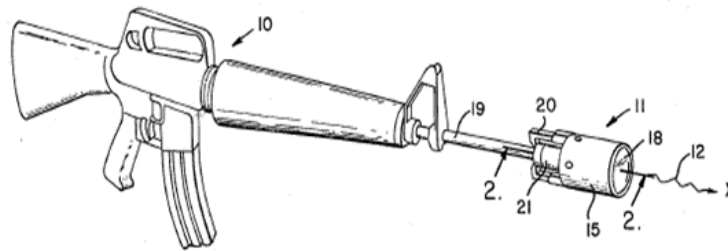

Fig. 6 - Drawing of M-16 rifle attached with laser weapon simulator [24]

(b) Laser Anti-Missile Defence System

An anti-missile system that uses laser to destroy the incoming missile before the missile reaches the target is developed by Peter M. Livingston and Alvin D. Schnurr [25]. In this system, the laser uses chemical fuel to supply the emission of high powered lasers. Unlike electrical powered lasers systems, chemical laser systems are physically smaller and more mobile, but come with a higher cost. The previous anti-missile system uses defensive missiles to fire at the incoming missile based on radar detection. The problem is the defensive missiles would miss. Even if the defensive missile successfully hit the incoming missile, the debris of missiles will interrupt the defence zone. More advanced missiles may also travel close to the ground, which leaves a short time for the defensive missile to hit it. Lasers however travel fast as light, faster than defensive missiles, and the aiming uses an infrared pointer, which is faster than radar detection alone.

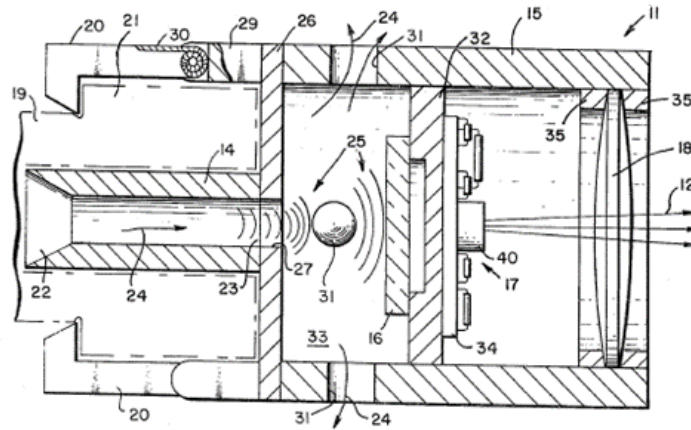

Fig. 7 - Cross-sectional diagram of laser weapon simulator [24]

As shown in Fig.8, the laser weapons (1 and 3) are mounted on vehicles to defend an area from missiles. In a situation, a ballistic missile (7) is fired towards a target (9). Line (5) on the ground shows the travelling of the missile (7). In the range of acquisition radar (6 and 8), the position of the missile is determined. The infrared sensor (10) will be alerted and used as a pointer tracker for the laser to be aimed at the missile. Then, the first laser beam (11) will be fired at the missile, heating the missile and at the same time, directing the second laser beam (13) to fire at the missile with the help of another infrared sensor (12). The laser beams were arranged to prevent overlapping between the laser beams. The heating by the lasers at a body part of the missile (15) will damage the missile, which will result in the destruction of missile. The overall diagram of Laser Anti-Missile Defence System Operation is depicted in Fig. 8.

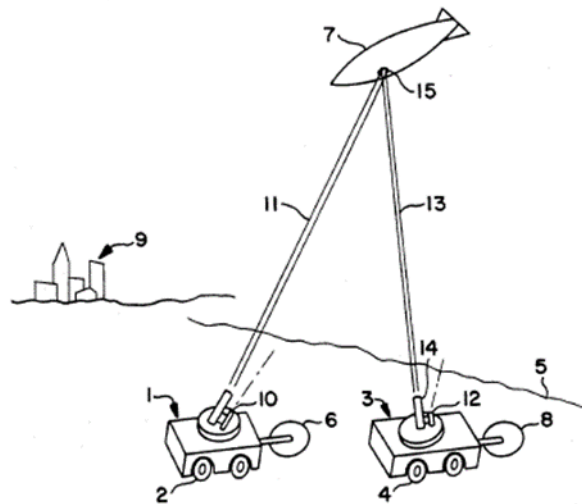

Fig. 8 - Diagram of Laser Anti-Missile Defence System Operation [25]

(c) Analysis of High Energy Weapon Employment from a Navy Ship

In 2015, Ching Na Ang from Singapore’s Civilian, Defence Science and Technology wrote a thesis on the application of High Energy Laser Weapon which will be used on a navy ship for Naval Postgraduate School in Monterey California [26]. The project aims to analyse the employability of laser weapons on Navy Littoral Combat Ship (LCS) class ship. This thesis analyses mainly discussed three different types of laser systems, including Solid State Slab Laser (SSSL), Free Electron Laser (FEL) and Fibre Optics Laser (FL), where all these three systems can produce high-quality laser beams. However, based on the findings, each laser systems have their unique pros and cons. For SSSL, the advantage is the power of the laser is scalable through the combination of beams, but the limitation is SSSL has low wall-plug efficiency, which means its total electrical-to-optical power efficiency is low. Next, FEL’s advantages include being able to produce a laser where the wavelength can be tuned, and the power of the laser can reach very high. However, the FEL system is large in size and is costlier compared to the other laser systems. Lastly, the advantage of using the FL system is since this system is widely used, there are a lot of developments available for

this system, and this system is energy-efficient and easier to cool. The disadvantage of the FL system is the performance can be reduced due to the unwanted effects of high energy non-linear optics.

The reason the three laser systems were analysed is to relate with the application of laser weapon system currently used by the US Navy. The elements that will be compared are the beam power, beam quality, wavelength, wall-plug efficiency and power requirement. Beam power is used as a measurement of how destructive the laser beam can be on a target. Beam quality is used to measure the accuracy of a laser beam on a point, where the best beam quality equals 1. On the other hand, the wavelength is important as the right wavelength is important to minimize the loss of beam power and quality. Wall-plug efficiency is the measurement efficiency of electrical to optical energy, where higher efficiency means lower losses in the form of heat to the surroundings. Power requirement is the required power to operate the laser weapon system. Table 2 lists the comparison between these three laser systems.

Table 2 - Comparison of laser systems

Name of Laser System	Name of Laser Weapon System	Beam Power	Beam Quality	Wall-plug Efficiency	Wavelength	Power Requirement
Solid State Slab Laser (SSSL)	Maritime Laser Demonstration (MLD) (Fig. 9)	105kW after combining 7 15kW laser beams	<3	20-25%	1.064 μm	400-500kW
Free Electron Laser (FEL)	Free Electron Laser System (FELS) (Fig. 10)	14.7kW	Approx. equals to 1	10%	Can be tuned	10MW
Fiber Optic Laser (FL)	Laser Weapon System (LaWS) (Fig. 11)	33kW after combining 6 laser beams	17	25%	1.064 μm	400kW
	Tactical Laser System (TLS) (Fig. 12)	10kW	2.1	30%	Not available	75kW



Fig. 9 - Maritime Laser Demonstration [26]



Fig. 10 - Free Electron Laser System [26]



Fig. 11 - Laser Weapon System [26]



Fig. 12 - Tactical Laser System [26]

In summary for the analysis, the most efficient laser weapons were the ones based on the SSSL system. The FEL is very challenging to be used on a ship due to the size of the laser system. Furthermore, the FL weapon system is a promising system to be used in the future due to the wide commercial use and developments of the system, with the expectation of the beam power of FL systems will eventually match or outmatch the SSSL.

3.2 Laser Technology in Medical Application

This section explores the laser technology used in dentistry, dermatology and ophthalmology in the medical sector.

(a) Laser Applications in Dentistry

In 2007, Herbert Deppe and Hans-Henning Horch proposed the use of laser specifically in surgery and implant dentistry [27]. Laser operation was proposed to replace conventional oral surgery dental surgeons will use drills and handpieces to operate the oral surgery. This study proposes the use of multiple uses of lasers to improve the current methods. Hence, using a laser is also more precise and less time-consuming. Furthermore, using laser for oral surgery will reduce the risks of infection, delayed bone healing, nerve damage, prolonged bleeding etc. Table 3 shows laser technology for different purposes in dentistry applications.

Table 3 - Laser Technology in Dentistry Application

Name of laser application	Description
Laser osteotomy	Osteotomy or orthognathic surgery is a surgery to cut, move, modify or realign the jawbone. Laser osteotomy using a 9.6- μm carbon dioxide (CO ₂) laser preserves more tissue than using physical cutting tools [28]. Laser cutting in this surgery also has a lower temperature rise and is more efficient than conventional drilling.
Laser in premalignant lesions of the oral mucosa	Oral mucosa lesions are the unwanted growth or swelling of epithelial tissue in the mouth. To replace the scalpel, a 10.6- μm CO ₂ laser is used to treat the tumour. This laser surgery was found to be more effective as patients have lower chances of the lesions growing back [29]. However, the downside of this laser treatment is delayed healing. Other methods of improvement are still under development to overcome this issue.
Lasers in fluorescence spectroscopy and PDT	Laser-induced fluorescence (LIF) spectroscopy is a method that uses a laser to diagnose cancer. The advantage of this method is it does not harm the patient or cause any side symptoms after the process [30]. This was proven with the use of a 337.1-nm nitrogen laser with a 600- μm fibre optic to differentiate normal and cancer tissues in a study.
Preimplant care of ailing implants	Before the surgery for dental implants, decontamination is important to prevent or minimize infection of gums around the implants. A study was conducted to study the effects of using laser and conventional method decontamination. Results have shown that laser treatment using 10.6- μm CO ₂ is much better than conventional methods [31].
Bare fibre technique in local hemostasis	Hemostasis is a surgery to prevent and stop bleeding. However, the increasing number of older patients makes it riskier to use conventional methods. Using laser hemostasis using pulsed 1064-nm Nd-YAG laser is proven to be safer with reduced side effects [32].

Besides the applications in Table 3, non-ablative lasers such as Nd: YAG (Fig. 13), diode (Fig. 14), and Er: glass laser which mostly releases infrared light are also widely used as lasers treatments produce fewer external wounds. Innovative non-ablative laser tools used in the modern dentist practice are the more effective and precise treatment of dental soft tissues method resulting in less wound and fasten healing

(b) Laser Applications in Dermatology

Lasers are also widely used in dermatology which is a medical field that specializes in the treatment of human skin, either for treatment of medical or cosmetic purposes. The main reason laser is used in dermatology is because the different types of lasers according to wavelengths can be used to target different layers of skin for specific treatment [35].

Laser resurfacing is a technique that involved the use of CO₂ and Er: YAG laser systems to target an area of the dermis. By using this technique, there will be some side effects. These effects can be infections and erythema. This will also increase the duration of recovery. However, these problems can be overcome with non-ablative lasers. Non-ablative lasers such as Nd: YAG diode, and Er: glass laser; mostly releases infrared light. During the process heats collagen and induces remodelling, the systems will target the water in the dermis as there is a system that will cool the

epidermis at the same time. Thus, the tissue will not be evaporated, and no external wound will be produced [36]. Fig. 15 shows the depth of penetration according to a different wavelength of lasers.



Fig. 13 - Nd: YAG laser [33]



Fig. 14 - Diode laser (808nm) [34]

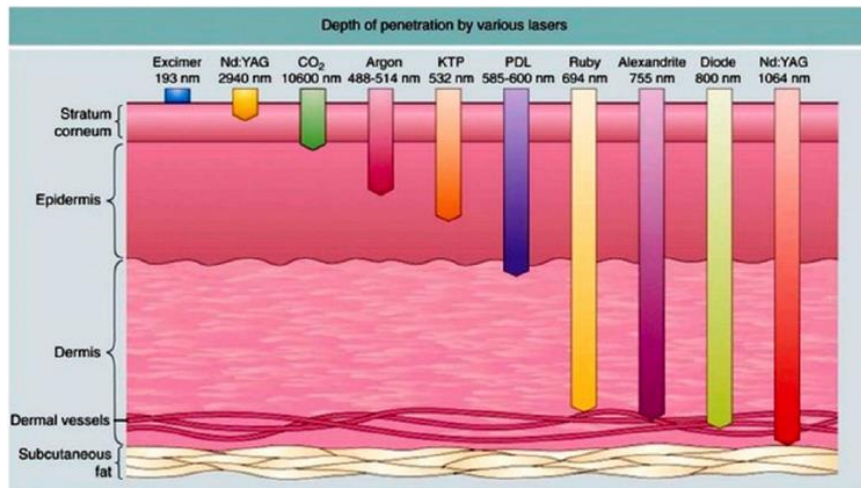

Fig. 15 - Depth of penetration according to a different wavelength of lasers [37]

(c) Laser Applications in Ophthalmology

The most common laser application in ophthalmology is LASIK eye surgery. LASIK eye surgery is the most performed laser refractive surgery to correct vision problems. These vision problems are near-sightedness (myopia), far-sightedness (hyperopia) and astigmatism. These procedures use a UV excimer laser to cut a thin surface layer of the central part of the stroma tissue to reshape the curvature of the corneal surface after the corneal flap is prepared by a femtosecond laser [38]. After that, the corneal flap is placed back for healing. The surgical procedure for LASIK is shown in Fig. 16.

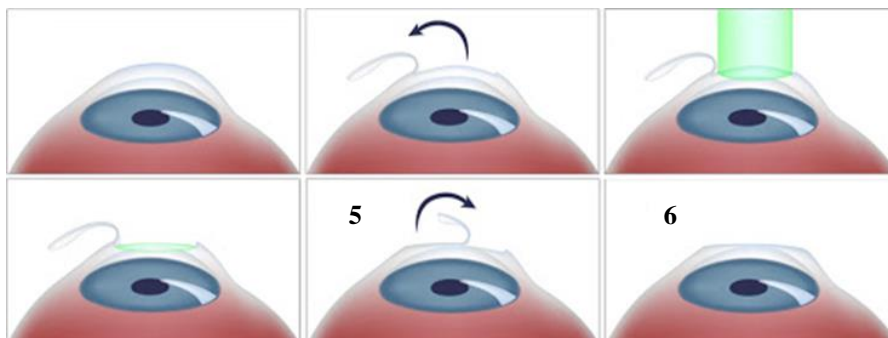

Fig. 16 - Surgical procedure for LASIK [39]

4. Conclusion

In conclusion, the study on the applications of laser technology in two critical sectors which are military and medical sector was reported. Laser technology was proven to be versatile and the elements that differentiate the purpose of a laser include laser power, accuracy, wall-plug efficiency, wavelength, power requirement and type of laser. Further studies should be continued to explore the potential of laser technology and for the improvement of the current laser technology.

Acknowledgement

The authors acknowledge the invaluable appreciation to the Universiti Tun Hussein Onn Malaysia, for funding this research project through the Multi-Disciplinary Research (MDR) Grant (H468). This is also a partnership project with Institut Teknologi Sumatera through grant Hibah Penelitian GBU45 (No. B/515/IT9. C/PT.01.03/2021). The facilities of this work is provided by Microelectronics & Nanotechnology-Shamsuddin Research Centre (MiNT-SRC), Universiti Tun Hussein Onn Malaysia.

References

- [1] A. Chodos, J. Ouellette and E. Tretkoff, *Einstein Predicts Stimulated Emission*, American Physical Society, vol. 14, no. 8, Aug./Sep. 2005. Accessed: Nov. 27, 2020. [Online]. Available: <https://www.aps.org/publications/apsnews>
- [2] M. Bertolotti, *The History of the Laser*. Boca Raton, FL, USA: CRC Press, 2004
- [3] A. A. Mudasaar, *Laser Physics*, August 2015. Accessed: Dec. 4, 2020. [Online]. Available: https://www.researchgate.net/publication/281235580_Laser_Physics
- [4] "The First Ruby Laser," in *What is a Laser?* LaserFest. Accessed Dec. 4, 2020. [Online]. Available: <http://www.laserfest.org/lasers/how/ruby.cfm>
- [5] W. M. Steen and J. Mazumder, *Laser Material Processing*. Springer-Verlag London, 2010, doi: 10.1007/978-1-84996-062-5
- [6] C. W. Kan, C. W. M. Yuen and C. W. Cheng, "Technical study of the effect of CO₂ laser surface engraving on the colour properties of denim fabric," *Coloration Technology*, vol. 126, no. 6, pp. 365-371, Oct. 2010, doi: 10.1111/j.1478-4408.2010.00270.x
- [7] S. Nourbakhsh, and A. Ashjarian, "Laser Treatment of Cotton Fabric for Durable Antibacterial Properties of Silver Nanoparticles," *Materials*, vol. 5, no. 7, pp. 1247-1257, Jul. 2012, doi: 10.3390/ma5071247
- [8] O.N. Hung, L.J. Song, C.K. Chan, C. W. Kan and C. W. M. Yuen, "Using artificial neural network to predict colour properties of laser-treated 100% cotton fabric," *Fibers Polym*, 12, pp. 1069-1076, Dec. 2011, doi: 10.1007/s12221-011-1069-1
- [9] Assyst Bullmer. *3D Body Measurements*, Assyst Bullmer Intelligent Solutions. Accessed: Dec. 5, 2020. [Online]. Available: http://assystbullmer.co.uk/3d_body_measurements.shtml
- [10] R. Nayak and R. Padhye, "The use of laser in garment manufacturing: an overview," *Fash Text*, vol. 3, no. 5, March 2016, doi: 10.1186/s40691-016-0057-x
- [11] R. Nayak, A. Singh, R. Padhye, and L. Wang, "RFID in textile and clothing manufacturing: technology and challenges," *Fashion and Textiles*, vol. 2, no. 9, Jun 2015, doi:10.1186/s40691-015-0034-9
- [12] M. Rose and H. Hogan, *A History of the Laser: 1960 – 2019*, Photonics Media, 2020. Accessed: Nov. 28, 2020. [Online]. Available: https://www.photonics.com/Articles/A_History_of_the_Laser_1960_-_2019/a42279
- [13] D. Kleppner, "Rereading Einstein on Radiation," *Physics Today*, vol. 58 (2), pp. 30, Feb. 2005, doi: 10.1063/1.1897520
- [14] R. Boyd, "Charles H. Townes (1915-2015)," *Nature*, 519, 292, March 2015, doi: 10.1038/519292a
- [15] A. Chodos, *May 16, 1960: Maiman Builds First Working Laser*, American Physical Society, vol. 19, no. 5, May 2010. Accessed: Nov. 27, 2020. [Online]. Available: <https://aps.org/publications/apsnews/201005/physics/history>
- [16] Columbia University Department of Ophthalmology, *It Happened Here: The Ruby Laser*, New York-Presbyterian, June 20, 2017. Accessed: Nov. 28, 2020. [Online]. Available: <https://www.columbiaeye.org/about-us/news-and-events/it-happened-here-ruby-laser>
- [17] T. S. Perry, *Red Hot*, IEEE Spectrum, 30 May 2003. Accessed: Nov. 20, 2020. [Online]. <https://spectrum.ieee.org/semiconductors/optoelectronics/red-hot>
- [18] C. K. N. Patel, "Continuous-Wave Laser Action on Vibrational-Rotational Transitions of CO₂," *Physical Review*, vol. 136, no. 5A, pp. A1187-A1193, Nov. 1964, doi: 10.1103/PhysRev.136.A1187
- [19] I. Hayashi, M. Panish and P. Foy, "A low-threshold room-temperature injection laser," in *IEEE Journal of Quantum Electronics*, vol. 5, no. 4, pp. 211-212, April 1969, doi: 10.1109/JQE.1969.1075759
- [20] J. Berg and A. Brown, *From gas-powered to laser-powered! NASA research team successfully flies first laser-powered aircraft*, NASA, Sept 2003. Accessed: Nov. 30, 2020. [Online]. Available: <https://www.nasa.gov/centers/marshall/news/news/releases/2003/03-180.html>

- [21] R. Ugwu, *Breakdown: What is Light Peak Technology*, Complex Newsletter, Feb. 23, 2011. Accessed: Nov. 20, 2020. [Online]. Available: <https://www.complex.com/pop-culture/2011/02/what-is-light-peak-technology>
- [22] A. C. Pylant, *Jellyfish Proteins Used to Create Unconventional Laser*, Photonics Media, May 31, 2017. Accessed: Nov. 30, 2020. [Online]. Available: https://www.photonics.com/Articles/Jellyfish_Proteins_Used_to_Create_Unconventional/p6/v146/i959/a62107
- [23] MARKETSANDMARKETS. *Laser Technology Market by Type (Solid, Liquid, Gas and Others), Revenue (Laser Revenue and System Revenue), Application (Laser Processing and Optical Communications), End User, Geography – Global Forecast to 2025*, Laser Technology Market, 2019. Accessed: Dec. 1, 2020. [Online]. Available: <https://www.marketsandmarkets.com/Market-Reports/laser-technology-market-795.html>
- [24] R. A. Dye, and D. A. Rowley, "Laser weapon simulator," *U.S. Patent No. 3,938,262*. Washington, DC: U.S. Patent and Trademark Office. Feb. 17, 1976
- [25] P. M. Livingston, and A. D. Schnurr. "Laser anti-missile defense system." *Northrop Grumman Systems Corp.*, 1993
- [26] CN. Ang, "Analysis of high energy laser weapon employment from a navy ship," Naval Postgraduate School Monterey CA Dept. of Systems Engineering, Sep 1., 2012
- [27] H. Deppe and H. Horch, "Laser applications in oral surgery and implant dentistry," *Lasers in Medical Science*, 22, pp. 217-221, Feb. 2007, doi: 10.1007/s10103-007-0440-3
- [28] G.K.H. Eyrich, *Hard-tissue drilling and cutting with a 9.6µm-CO₂-laser*. University of Zurich, Faculty of Medicine, 2003
- [29] H. Deppe, M. Hillemanns and W. Hauck, Recurrence Rates of "Premalignant Lesions after CO₂ Laser Vaporization," *Medical Laser Application*, vol. 19, no. 1, pp. 55-60, 2004, doi: 10.1078/1615-1615-00124
- [30] N. M. Broer, T. Liesenhoff, and H. H. Horch, "Laserinduced Fluorescence Spectroscopy for Real-Time Tissue Differentiation," *Medical Laser Application*, vol. 19, no. 1, pp. 45-53, 2004, doi: 10.1078/1615-1615-00123
- [31] H. Deppe, H.H. Horch, and A. Neff, "Conventional versus CO₂ laser-assisted treatment of peri-implant defects with the concomitant use of pure-phase beta-tricalcium phosphate: a 5-year clinical report," *Int J Oral Maxillofac Implants*, vol. 22, no. 1, pp. 79-86, Jan-Feb. 2007, PMID: 17340900
- [32] H.H. Horch and M. Herzog, "Progress Report on Laser Therapy in Oral and Maxillo-Facial Surgery," In: Waidelich W., Waidelich R. (eds) *LASER Optoelectronics in Medicine*, Springer, Berlin, Heidelberg. pp. 417-421, 1988, doi: 10.1007/978-3-642-72870-9_110
- [33] C. Fornaini, "Research: Nd:YAG lasers in intraoral welding", *Laser, International Magazine of Laser Dentistry*, Germany, vol. 5, no. 2, pp. 06-10, July 1, 2013
- [34] BIOLASE. *iLase*. Accessed: May 21, 2021. [Online]. Available: <https://www.biolase.com/ilase/>
- [35] A. Aslam and T. S. Alster, "Evolution of laser skin resurfacing: from scanning to fractional technology," *Dermatol Surg.*, vol. 40, no. 11, pp. 1163-72, Nov. 2014, doi: 10.1097/01.DSS.0000452648.22012.a0. PMID: 25285818
- [36] M. R. Avram, A. M. Avram, and P. M. Friedman, *Laser and Light Source Treatments for the Skin*. New Delhi, India: Jaypee Brothers Medical Publishers, 2014
- [37] K. Stolman, MD, "Treating Superficial Leg Veins with Laser," *The dermatologist*, vol. 23, no. 2, Feb. 2015
- [38] J. T. Lin, "Mini-excimer laser corneal reshaping using a scanning device," in *Proceedings of the SPIE*, vol. 2131, pp. 228-386, July 1994. doi:10.1117/12.180716
- [39] Envisioned. *Lasik*, Envision. Accessed: Dec. 4, 2020. [Online]. Available: <http://www.envisionoptical.com/lasik/>