

Variable Frequency Drive Optimization with Adaptive Neuro Fuzzy Inference System

Rekha Mudundi^{1,2*}, Malligunta Kiran Kumar¹

¹ Research Scholar, Department of Electrical and Electronics Engineering,
Koneru Lakshmaiah Education Foundation, Vaddeswaram, Guntur, Andhra Pradesh, 522302, INDIA

² Assistant Professor, Department of Electrical and Electronics Engineering,
Gokaraju Rangaraju Institute of Engineering and Technology, Telangana, 500090, INDIA

*Corresponding Author: rmudundi@gmail.com

DOI: <https://doi.org/10.30880/ijie.2024.16.03.029>

Article Info

Received: 3 March 2024

Accepted: 14 November 2024

Available online: 23 November 2024

Keywords

Adaptive neuro fuzzy inference system, fuzzy logic control, artificial neural networks, q-axis average current, q-axis ripple control, DC-bus-voltage-ripple, Adjustable frequency drive

Abstract

The output power of drive should be controlled to avoid stress on the advanced components in the input power system of the 1- \emptyset AC source; this is powered to the three-phase (3- \emptyset) variable frequency drives (VFDs). To deal these issues, an integrated artificial neural network (ANN) and fuzzy logic control (FCL) named as adaptive neuro fuzzy inference system (ANFIS)-based VFD optimization is proposed to mitigate the stresses above the various parts of VFD such as input side, terminal block, direct current (DC) capacitor bus, current harmonics, torque ripple and speed of the induction motor (IM). In addition, the proposed ANFIS with the supervisory learning approach is utilized to regulate the speed with mitigated rise time and settling time of the VFD system. The proposed ANFIS model is simulated in MATLAB/Simulink environment and compared with several conventional VFD optimization. The extensive simulated performance shows that the proposed ANFIS-based VFD has achieved better results than conventional VFD optimization techniques.

1. Introduction

VFDs are utilized in association with fan and pump applications and change the speed of the pump or fan based on the required demand, which will ultimately result in effective energy savings. Additionally, VFD can also vary the capability of artificial based synthetic lift system by automatically changing the speed of the motor. The motor RPM is controlled by varying the power frequency applied to the corresponding motor and the pump capacity varies linearly with the RPM respectively. Therefore, optimal production can be achieved by adjusting the pump performance with its flow performance [4]. This can reduce the need to modify the pump capacity to suit the right environment or enhance running life by stopping the system cycling process. The frequency change can be performed manually or automatically based on the predicted data. The VFD can automatically change its operational frequency to sustain the current, flow rate, target pressure. Normally, a VFD can be used efficiently in load changeable applications such as compressors, fans, and pumps respectively. By utilizing the VFDs in pumps and fans 30-50% of energy will be saved compared to the conventional approaches and 35 % of power saving achieved in compressors.

1.1 Working Principle

A VFD efficiently adjusts the frequency of the electric power applied; hence it gains control over AC motor with respect to its rotation speed. They are often named as variable voltage variable frequency (VVVF) drive, adjustable-speed drive (ASD), PWM drive, AC drive, adjustable-frequency drive (AFD) or inverter drive [19]. A VFD operates efficiently by generating DC power by passing the AC power through the diode-based bridge rectifier, and then the ripples will be removed by passing it through a filter. It also smoothed the output voltage and finally the output voltage controlled across the inverter section and the controlled frequency and voltage applied to the motor's high speed bipolar transistors [18]. However, incorporating VFD into existing systems or new systems increases the initial investment. Additionally, due to the rapid development and many benefits of the VFD technology, the pumping stations around the world have been fitted with VFDs, they can speedily change the operation of pumps and efficient energy saving is achieved by comparing with another modes of operation, and finally they are utilized as power conversion devices for driving motor. This will be helpful for realistic manufacturing applications such as rural irrigation, beam pumps and pumping stations in any remote locations used to extract oil from deep wells, which are some of the unique applications to increase up 3- ϕ VFDs from 1- ϕ ac source owing to inaccessibility of 3- ϕ power.

1.2 Need for Optimization

The major limitations of the 3- ϕ VFD operation compared with 1- ϕ ac source are as follows, thus requiring optimization as follows. The RMS value of the input AC source must be two times compared to the 3- ϕ supply is utilized for the specified load. The higher current demand must be handled by input diodes like the specified load. Since the dc bus capacitor is utilized with the diode rectifier, thus the instantaneous value of the input voltage is applied and the current flows only when it is greater than the DC-bus voltage. If the input is 1- ϕ ac source, then the current flow is irregular and has considerable peaks. This unwanted peak creates the unwanted thermal stress in the diodes, and it leads to early failure. The input ac power terminal blocks are affected by high input current. The terminal blocks might not be rated to control the high RMS current repeatedly.

If 1- ϕ input is utilized to power 3- ϕ inverters, then it leads to high input current harmonic distortion. These harmonic distortions cause lesser input power factor causing the reduction of system efficiency. The higher ripple voltage in dc bus is generated by 1- ϕ ac supply. Thus, the capacitor faces heating issues, by passing high ripple currents which are generated from higher ripple voltages. This will ultimately result in a derated inverter. The non-regenerative circuit is shown in Figure 1 integrated among the inverter and rectifier to give power from 3- ϕ VFD utilize from 1- ϕ ac supply. Then, the output power of the drive should be controlled to prevent the advanced component stresses presented in it, both the input powered systems. Therefore, it is necessary to deal with all the issues mentioned above, where several researchers presented the techniques in [4-10]. The traditional boost topology used to improve the VFDs has a major drawback supplied in voltage are overcome. In [6] authors discussed the coupled inductors utilized bridgeless rectifier has developed with the bridgeless rectifier. In this topology, the input ac side has a boost inductor respectively. However, a significant disadvantage of all the bridgeless rectifiers is the rectification operation it requires fast-recovery and high-speed diodes, this makes the design more expensive.

In [7] authors discussed about, the effective utilization of series connection of two capacitors forming a dc bus. It relates to the one phase of 3- ϕ ac motor. The four-switch H-bridge topology output phases are connected to the left side of the 3- ϕ ac motor. This topology shows the regenerative property, and this property is used in many industrial applications. In [8] authors developed a new structure by utilizing the B4 topology effectively. This new structure also uses the extra switches for extra interconnection alternatives for motor windings respectively, the windings are B4vzfz, B4vf and B4f. The extra switches complicated the system and increases the system cost compared to the conventional six switch based B6 topology. In [9] authors exploited various versions of these topologies for better performance. In these topologies, the input 1- ϕ ac supply is connected to one of the motor windings. The remaining phases are limited in PWM manner to develop a positive level of voltages without ripples. EMI and Common-mode voltage are supplied back to the original source remains the significant problem. The supplied switches also required higher voltage ratings, which should be optimal for this defect.

In many countries, they use 1- ϕ ac source for all electrical devices, so 3- ϕ VFDs are needed to convert with 1- ϕ ac source. But it is complicated task because 1- ϕ ac source has more ripples than the 3- ϕ ac source. The initial problem is that, due to the high ripple currents, the capacitors are overheated. Unfortunately, most of the systems need low peak current rating of the diodes compared to the dc bus capacitor ripple current rating. For those systems, the output power was controlled by utilizing the dc-bus voltage-ripple base frequency-crease-back approach. This process reduces the mean time between failures (MTBF) of the corresponding diodes. Also, the input terminal pieces, and input diodes current rating should be monitored properly. To solve these issues, many VFD approaches uses three methods to properly maintain the 1- ϕ ac supply from the 3- ϕ VFDs powered source.

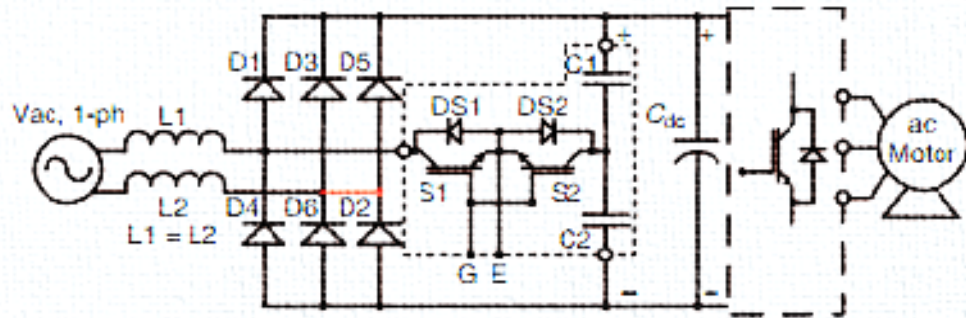

Fig. 1 Non-regenerative 1- ϕ active front-end circuit [8]

Here, an external inductor is used to store the energy and with the help of bidirectional switch, the energy was retrieved. This approach is perfectly suitable for the VFDs with easy integration as shown in figure 1. This is practicable as the voltage was supplied at the DC-bus midpoint and single phase. Here, the external inductor is used to limit the current flow, this acts as a boost inductor. The major drawback of this method is boost inductor should be high and in the range of 0-0.2 p. u. It means, the switching frequency is more than twice that of supply frequency respectively [11]. The low switching frequency will effectively reduce the electromagnetic interference induced at the input source. By utilizing this extra hardware increases the size and cost of the system. Thus, in combination with the derate choice, new methods of control algorithms need to be utilized for improving the reliability and performance of VFDs at reduced cost. To solve this problem, in [13] authors described the new control method named as frequency fold-back approach. The DC-bus capacitors ripple voltage was sensed and measured in this method. By measuring this voltage, ripple-current of DC-bus- can be calculated effectively without any loss as the DC-bus- ripple current is not directly measurable. In [14] authors adapted the new method to reduce the power rating of 1- ϕ ac sources operated 3- ϕ VFDs. But this method was not applicable to reduce the stress occurred in the VFD, due to RMS current and peak current of the diode. The standard fold-back approach contains the proportional-integral (PI) based control algorithm; this algorithm generates the ripple value set point depending on VFDs 3- ϕ rating respectively. But the major problem is the ripple-voltage of DC bus capacitors tolerance factor might be advanced than RMS current capability of input terminal blocks. This algorithm might reduce the output power by controlling the output frequency respectively. The reduction of the DC voltage creates the increment in the input current at the specified load and hence it affects the terminal blocks and input diodes respectively [20]. Thus, the ripples presented in the DC-bus voltage must be reduced by controlling the external factors synchronously. To solve these problems, the designers have introduced VFD in [15]. But this method does not reduce the stresses applied to the various components of the VFD especially the terminal blocks and the input diodes.

In [16] authors presented the effective approach to protect the drive. The protection can reduce the stresses presented in the various components of the VFD across the DC bus capacitors and input side respectively. In this method the output power can be effectively controlled by reducing the output frequency. Also, the output power can be controlled by reducing the ripple amplitudes of the Q-axis system as an effective alternative to the regular reduction of the DC-bus-voltage ripple. The major drawback of this approach is that it does not reduce the stresses above the AC motor that is more occurrence of torque ripples in the motor; this problem generated if the AC motor [24-25] operated at various ranges of speed through the different frequencies respectively. Recently, a MQAC with torque ripple control of an IM and STP-PSO controller is proposed in [17]. However, existing works utilized the PI controller, which required the continuous tuning of its parameters like gain. Additionally, this article proposed the ANFIS controller, which integrates the ANN controller [21-23] with fuzzy membership functions (MFs) that control current harmonics, effective torque ripple and dynamic performance by reducing the stresses above IM to further enhance the lifetime and reliability of VFDs, unexpected changes in the load and speed respectively. The major contributions of the proposed approach are as follows.

An advanced control technique is implemented above the ANN by utilizing ANFIS for effective optimization of the VFD's by mitigating the stress above IM, unexpected changes in the load and speed respectively to the different components. In addition, the FLC technique was also implemented to show the effectiveness of the proposed ANFIS-based controller technique compared to the other techniques. Only some researchers have presented the control schemes for VFD optimization like DC-bus voltage ripples, M-QAC and STP-PSO to improve the life span of VFD's by reducing the stress of different components. An extended framework is developed for additional removal of stresses generated over the different components and FLC, IM utilizing ANN, ANFIS-based controllers for reducing the drawbacks of various works presented in the literatures [15], [16] and [17] respectively.

The remaining part of the paper is prepared as follows: section 2 deals with the operational study of ANFIS controller. Section 3 deals with the detailed analysis of proposed control strategy by using the ANN based ANFIS controller. Section 4 deals with the detailed simulation analysis of proposed method and results are compared with the various literatures and state of art approaches. Finally, section 5 deals with the conclusion and possible future enhancements of the proposed method.

2. Background: ANFIS Controller

Artificial intelligence based Neural networks (NNs) are successfully applied to the different types controlling applications, such as image analysis, speech recognition, and electromechanical control strategies in robotic industry. ANNs are one of the prominent controlling mechanisms, which is effectively used for classification, time series prediction, optimization, and control of electrical hardware. Thus, the NNs are the capacity to train and test the different parameters of IM respectively. NNs in the IM gives the extreme benefits of fault reduction properties and fast parallel calculation respectively. Recently, most of the work has been focused on development of power electronics and ac drives by utilizing ANN based control mechanism. FLC is the best example for these types of applications, and it is used to control all parameters in real-time hardware systems as they are combined with the NNs outputs. Anyhow implementation of NNs in such networks is bit difficult. Specifically, it is difficult to assign the weights for each neuron in the electrical systems.

To solve this problem, it is easy to implement NNs in fuzzy based rule models as most control systems rely on fuzzy based logic so that IF-THEN rules and linguistic terms are fully utilized in the system. As the FLC cannot learn itself, they are trained with NNs respectively. For this training process, FLC systems adopt the techniques from a variety of areas such as system identification and statistics. Thus, the combination of fuzzy logics and neural networks forms a new hybrid mechanism known as ANFIS system, it has maximum learning power compared to the conventional approaches. The MF of inputs and outputs are more adjustable and contain the maximum data. This sample data is generated by the NNs training in the drive. Some parts of the system are specifically assigned for the training; hence the ANFIS method is more accurate. The ANFIS based rules satisfies the linguistic forms, thus the temporary intermediate results can be examined easily. To initialize the ANFIS strategy, modeling of target systems should be required by training the datasets, they should be created with the desired combinations of input-output pairs. To design the ANFIS controller the following parameters must be required. They are number of data pairs, checking data sets, viz., and training data sets. For Fuzzy inference systems, the output learning results should be approved after specifying the number of epochs to be selected and the step learning level to begin the training process.

The controlling of IM using the ANFIS control algorithm is as follows; this method contains the same FIS process with extra NN blocks. The NN structure is created by utilizing the network layers l1 to l5 as follows,

- Layer 1: this layer uses the MFs as adjustable inputs such as input 1 and 2 respectively. As it utilizes multi-inputs, bell-shaped or triangular MFs are used effectively. The major duty of this layer is to supply the input weighted values x_i (where $i = 1$ to n) to the next layers.
- Layer 2: it is a membership layer, and it adjusts the weights of every MFs. The received x_i values from layer 1 act as the weights of MFs. Here, the fuzzy sets are generated based on the adjustment of these inputs respectively. Additionally, it also calculates the membership values to identify the efficient degree. The input x_i values are assigned to the fuzzy sets based on these degrees.
- Layer 3: it is a rule layer used to match the fuzzy rules with the help of each node of layer and each node calculates the weights. They calculate activation level of every rule, and the total numbers of these fuzzy rules are equal to the number of layers.
- Layer 4: it is a defuzzification layer used to generate the output values y based on the optimal suggestion from the rules. Layer 3 and layer 4 are associated with each other for weight sharing through fuzzy singletons. These singletons develop the other important parameter set for respective neuro fuzzy network.
- Layer 5: it is an output layer used to combine layer 4 outputs. Finally, it transforms those outputs into a binary (crisp) classification result.

The ANFIS algorithm operates automatically with the back-propagation algorithm and least-square-estimation. The ANFIS strategy is more flexible in controlling the environment, thus it is widely used in various applications. The ANFIS controller takes the perfect control decision on each operation in the system. ANFIS also provides better stability in the system and reduces disturbances; the electrical equipment is safeguarded from external damage respectively. This paper majorly focused on controlling the various parameters of IM through the ANFIS controller as shown in figure 2. The controlling parameters are current, voltage, torque, flux, and speed.

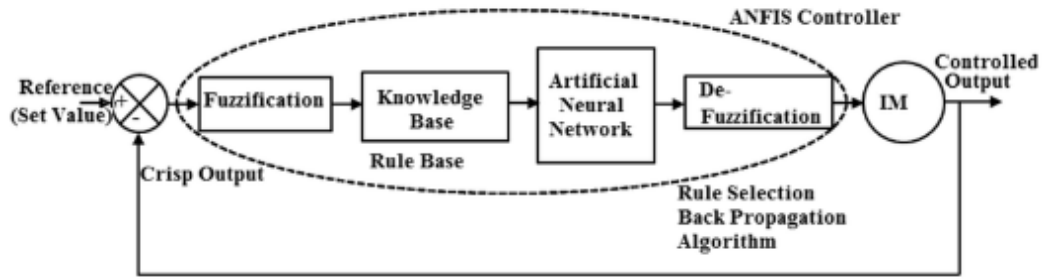

Fig. 2 Block diagram of ANFIS controller

Fuzzy sets are developed from the application of FLC, the fuzzy sets do not contain fixed numeric variables, but they hold the special linguistic variables. Thus, the linguistic variables are the minimum to maximum properties of the fuzzy sets. These fuzzy sets are an advanced form of binary 'crisp' dataset; here an element can be capable of belonging to the entire membership set or not belonging to no membership set respectively. Let A be the fuzzy set with universe of elements X , it is denoted by the collection of generic element pairs $x \in X$ and its MF is $\mu : X \rightarrow [0, 1]$. Hence, each element x of X associated by a number $\mu_A(x) : X \rightarrow [0, 1]$ respectively. The FLC operation is developed by fuzzy control rules between the linguistic variables. These fuzzy control rules are effectively represented by the conditional statements. The proposed speed control mechanism of IM motor using an ANFIS controller with four significant parts. They are de-fuzzification, NN, knowledge base and fuzzification blocks respectively. Initially, the inputs are applied to the ANFIS controller that is the change in error and error are formed by utilizing the following Equations.

$$e(k) = \omega_{ref} - \omega_r \quad (1)$$

$$\Delta e(k) = e(k) - e(k - 1) \quad (2)$$

Here $\Delta e(k)$ is the change in error, $e(k)$ is the error, ω_r is the actual rotor speed, and ω_{ref} is the reference speed. The Fuzzification unit generates the linguistic variable from the binary crisp data source. These linguistic variables are applied to rule-based blocks. By effectively utilizing previous knowledge, the set of rules are written into the rule-based block. The output of this block is applied as input to the ANN block. Here, the back propagation approach is used to train the NN by using the proper rule selection. The control signal is developed by proper training of the perfect rule base respectively. The optimal output is developed from the accurate firing of control signal-based rules. The output of ANN unit is applied to the de-fuzzification unit and finally binary crisp data generated from the linguistic variables respectively. The fuzzification process is as follows; the first step is the generation of crisp variable or fuzzy variable from the change in error. The linguistic labels of fuzzy sets are mapped from these two errors. Each linguistic label is connected to the triangular type of MF. The inputs used are fuzzified through this triangular type of MF by utilizing the fuzzy sets and applied as input to the respective ANFIS controller. The defuzzification process creates a numeric data.

3. Proposed Control Model

An Artificial network is formed by interconnection of multiple directional links and numerous numbers of nodes as shown in figure 3. The detailed operation of ANFIS layer approach is presented in section 2. The learning rule is majorly used to control these parameters and modify the parameters to reduce the prescribed error level. The fundamental operation of the artificial networks learning rule is developed based on the chain rules and the gradient descent rules. FLC is an appropriate method to deal with fuzzy and non linear systems respectively. ANN is effectively utilized for rapidity, robustness, adaptation and learning respectively. The ANFIS system utilizes the advantages of the ANN and FLC approaches. To reduce the limitations of individual ANN approaches and fuzzy systems, it is better to utilize the combined hybrid approach, thus this concept leads to the development of novel neuro-fuzzy controllers. The fundamental process of neuro-fuzzy controller uses an effective training process for identifying the accurate fuzzy set logic rules. Then, fine tuning of MFs can be achieved by the parameter learning algorithms of the controller. Figure 4 presents the proposed Neuro-Fuzzy controller structure and it consist of defuzzification, inference engine and fuzzification parts with its layers. In this hybrid method, the input nodes presented in the input layer are used for monitoring the input states and output nodes presented in the defuzzification layer are used for the generation of output decision or control signals respectively. The nodes presented in the fuzzification and inference layers are used for the operation of

Function and MF's

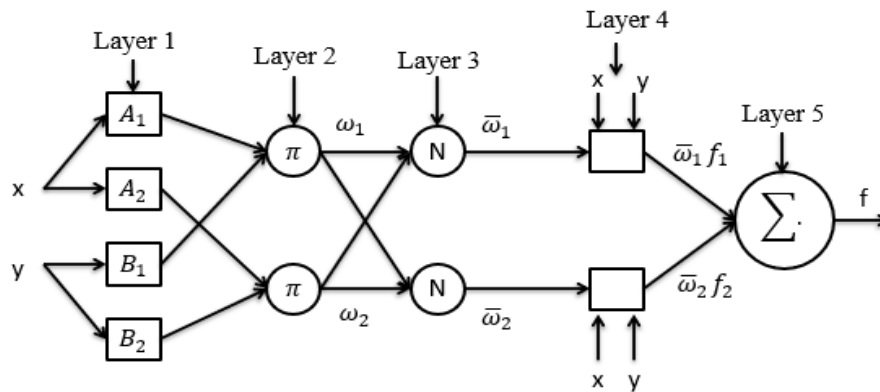

Fig. 3 Architecture of ANN model

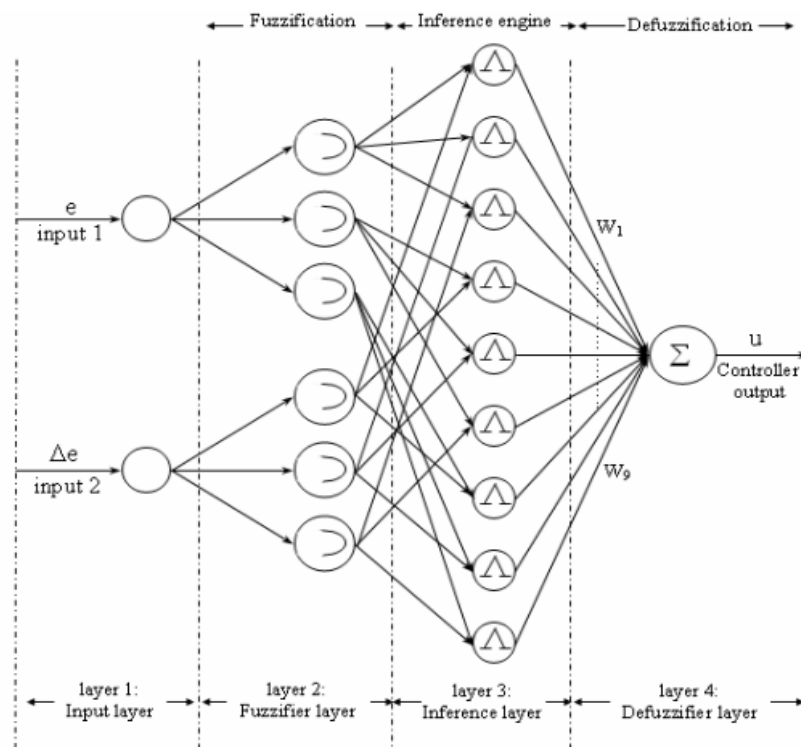

Fig. 4 Neuro-fuzzy controller structure

Figure 5 presents the detailed operation fuzzy supervisory learning with ANFIS controller. Here, the error conversion rate ΔE and the error signal E are applied as input to the fuzzy critic in the neuro-fuzzy controller. Both the error signals are generated from the comparator. The nonlinear quantization and MF are used for the fuzzy process in the neuro fuzzy controller. Here, the fuzzy critic is used to develop efficient fuzzy rules with simple structure that include 9 rules and only 3 MFs respectively. By the effective adaptation of supervisory learning through fuzzy critic, POS, ZE and NEG MFs are treated as the three input variables. The fuzzy-rule based on relationship method consists of Mamdani type of fuzzy based IF-THEN rules. The fundamental mathematical formula is as follows: R_i : IF E is A_i and E is B_i THEN u is C_i ; for $i=1, \dots, 9$. Here, u is output and $E, \Delta E$ are inputs respectively. And the C_i is output linguistic variable and A_i, B_i are the input linguistic variables respectively. The final output generated is the weighted mean of every fuzzy rule's output. The neuro-fuzzy controller can generate the $[-1, +1]$ range of stress signal in worst cases, while controlling the IM. This stress is solved by the fuzzy critic, and it calculates the performance of the controller by monitoring the change in error and error signals. By utilizing this binary controlled data, the VFD operates efficiently and generates the output $Y(=W)$. If any stress or errors occurred in the VFD drive, it is feedback and again applied as input to the system. Now, the ANFIS control mechanism reduces the stresses and errors and finally generates the new control signal for drive. This process continues automatically and gives the maximum reliability and performance.

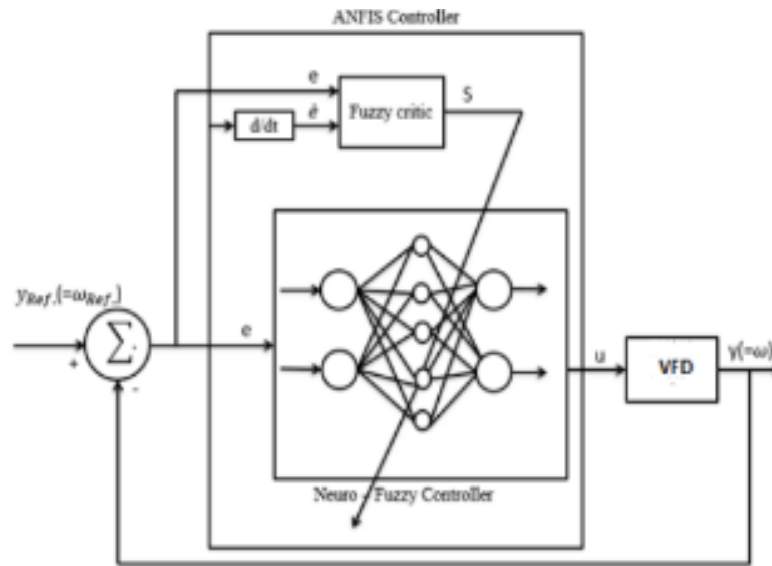

Fig. 5 ANFIS controller with fuzzy supervisory learning

4. Results and Discussion

This section deals with simulation results, which are conducted on pumping load operated at 230V, 0.75-hp, 1-∅ ac source powered 3-∅ VFDs. Table 1 presents the detailed setup. The proposed ANFIS controller compare with the ANN, FLC, STP-PSO [17], M-QAC [16] and it also compared with the traditional dc-bus-voltage ripple-based fold-back method [15]. Finally, the results are generated with the time period of 50 seconds using a conventional DC-bus voltage ripple-based method. The results include the input current, output frequency, and output power and dc-bus voltage respectively.

Table 1 Parameter values of motor and VFD utilized

	One-Phase Rating	Rated Speed	Rated Current	Rated Voltage	Rated Power
Pumping Application					
3-∅ Motor	N/A	3.450 r/min	2.1 A	200-230 Vac	0.5 hp
3-∅ VFD	0.33 hp	1.5-400 Hz	3.5 A (out)	200-240 Vac	0.75 hp

Figure 6 represents the conventional I_q-Ripple current method [13] performance analysis for time 50sec. From the figure, it is observed that while converting AC to DC, ripples are generated in the dc bus voltage. This voltage is again applied as the input to the q-axis current of the drive. Again, this drive output is converted back to the AC, thus a few distortions will be induced in the input current. Three phase output power and rotor speed depending on the output frequency as well as the input current. Figure 7 represents the scenario of comparison with the I_q-mean current method [16] for 50 seconds period, here the effective removal of ripples is achieved and the steady state stable performance of the system, which is better than the conventional I_q-ripple current method [16]. If there is any variation in the output frequency and input current, then the three-phase output power and rotor speed will change accordingly. Figure 8 represents the outputs of the TRC test results [17], where the output frequency and input current are achieved from the steady state stable performance bit above I_q-Ripple and I_q-Average currents. From the figure, it is also observed that there are no ripples presented in the output frequency as perfect as input current and it is continued the steady state performance value of less than 3sec. Figure 9 represents the results of the STP-PSO [17] method, here the input current and output frequency steady state stable performance values are achieved at 0.74sec of time period. This leads to a reduction of output power and rotor speed, which creates stresses above the load levels, and it should be minimized.

The results obtained using the FLC system is shown in figure 10, where the output power is about 0.26hp, it is in the rage of 1-∅ rating drive. The I_q-Ripple current method performance analysis obtained a steady state value

at 0.45sec time, where the dc bus voltage (that is 20.2V) contains less ripples above the presented control systems. After the first AC to DC voltage conversion, the DC voltage is applied as input to the drive q-axis current. Finally, after converting back to AC again, then there are no distortions presented in the input current as perfect (i.e. 26.3A) as the output frequency. The rotor speed of 0.62pu generated from the three-phase output power and input current is appropriate as the output frequency. If there is any variation in the output frequency and input current, then the three-phase output power and rotor speed will change accordingly. Additionally, the test results of the ANN control system are demonstrated in Figure 11, where the output power is around 0.22hp, which is lesser than that provided by the control systems and even the FLC system is within the range over 1- ϕ rating of drives.

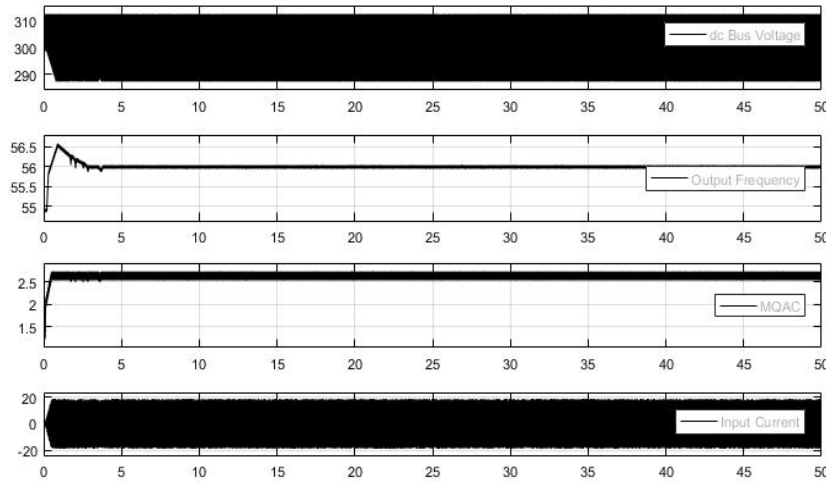

Fig. 6 Simulation results of proposed *q*-axis current method for frequency fold-back [13] *I_q*-Ripple current method

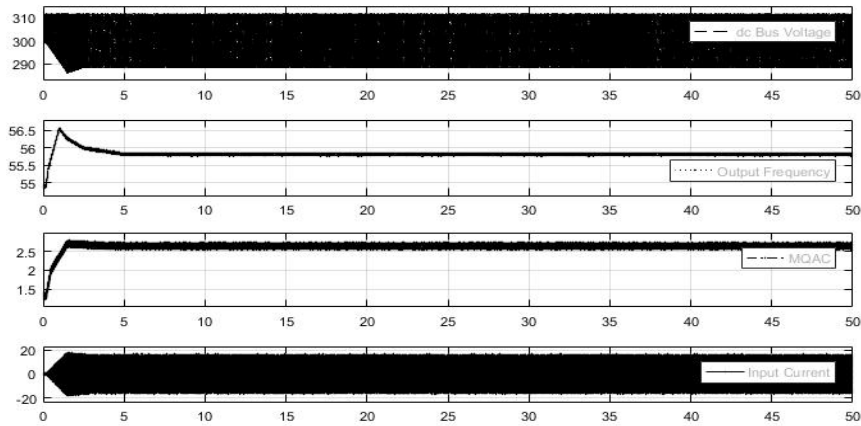

Fig. 7 Simulation results of proposed MQAC method for frequency fold-back [13] with *I_q*-Average current method with 50sec

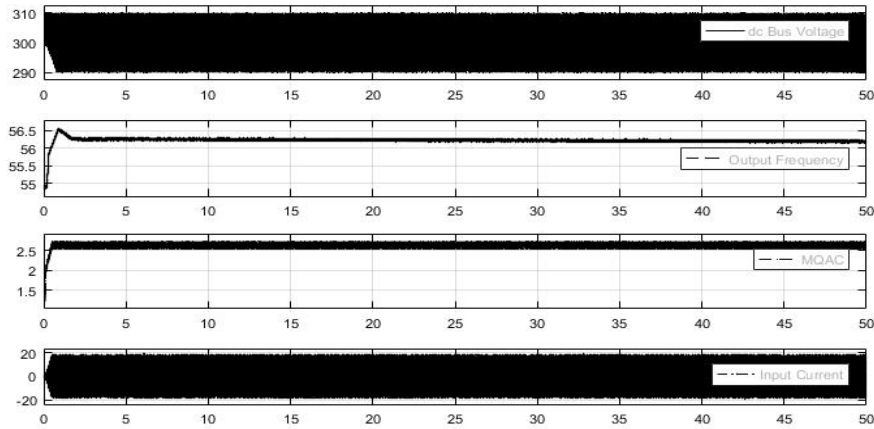

Fig. 8 Simulation results for torque ripple control method [17] with 50sec

It also shows the IQ-Ripple current method performance analysis achieved steady state at 0.1 sec time, in which V_{dc} is 19.4v, current is about 3.2A and speed of the motor is 0.59pu .Figure 12 shows that test results utilizing ANFIS controller, where the output power was achieved at 0.20hp that is in the range 1- \emptyset rating of drive's and quite superior as compared presenting controlling schemes, FLC system and ANN controller. It obtained a steady state performance of the IQ-Ripple current method at 0.02 seconds of time period, here, peak-to-peak voltage V_{dc} is 16.8V, peak-to-peak current is about 3A and speed of the motor is 0.5pu. Additionally, Table 2 demonstrates that steady state values for a practical pumping application with presenting and proposed control methods.

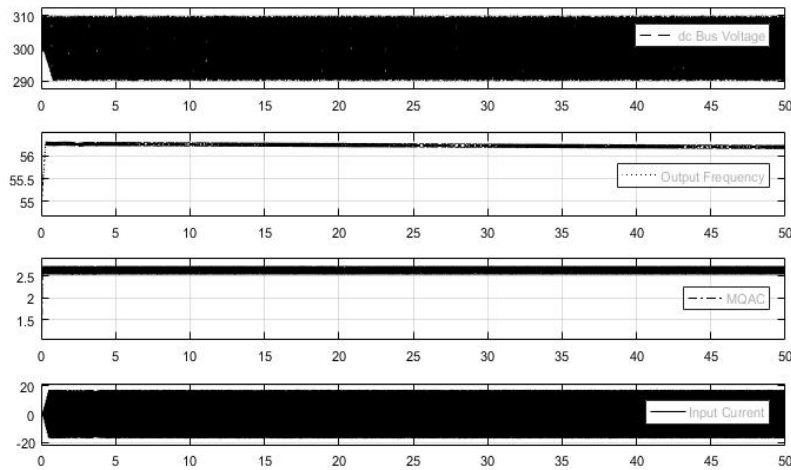

Fig. 9 Simulation results for the STP-PSO method [17] for 50sec

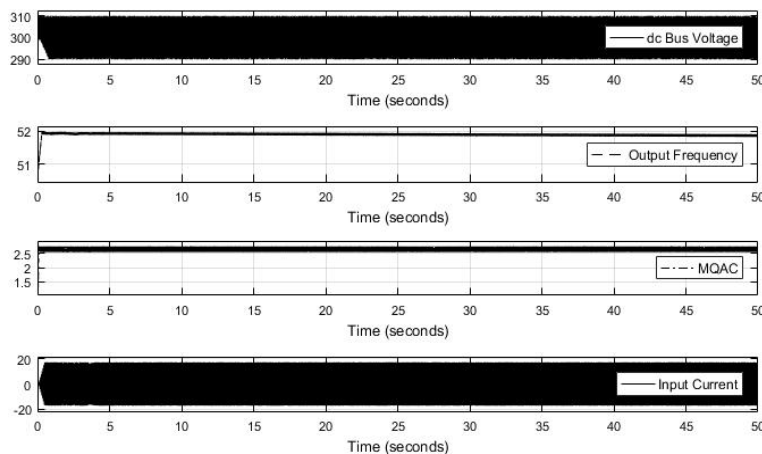

Fig. 10 Simulation results for the FLC system for 50sec

It is shown that parameters like Vdc (peak-to-peak), IINPUT(peak-to-peak), IINPUT(RMS), motor speed (per unit) and POUTPUT are considered to disclose the effectiveness and robustness of proposed control methods FLC system, ANN controller and ANFIS controller with comparison to present the DC bus ripples presented in voltage method [15], q-axis ripple current method [16], q-axis average current method [16] and even that of TRC method [17] and STP-PSO [17] controlling approaches. From Table 2, ANFIS controller outperforms all presenting, proposed FLC and ANN control methods by obtaining the steady state performance with minimal time and all the values are within the range of drive's 1- ϕ rating. The optimal values of all considered parameters are highlighted in bold letters for better visualization, where the ANFIS controller achieves minimal values, which results in mitigation of stress above various parts of the VFD such as diodes at input side, terminal block, DC bus capacitors, current harmonics, torque ripple, and dynamic performance for rapid alters in the load and speed of IM.

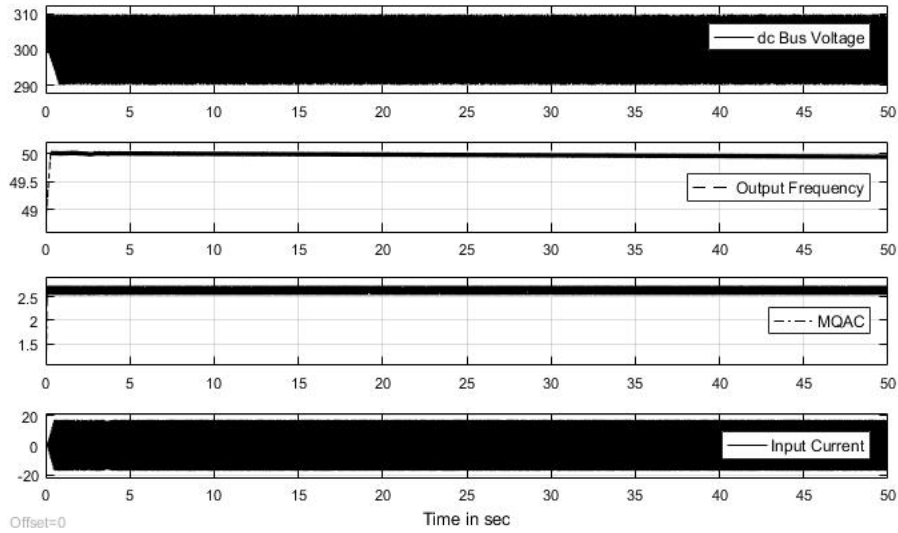

Fig. 11 Simulation results of proposed ANN controller for 50sec. output frequency and M-QAC

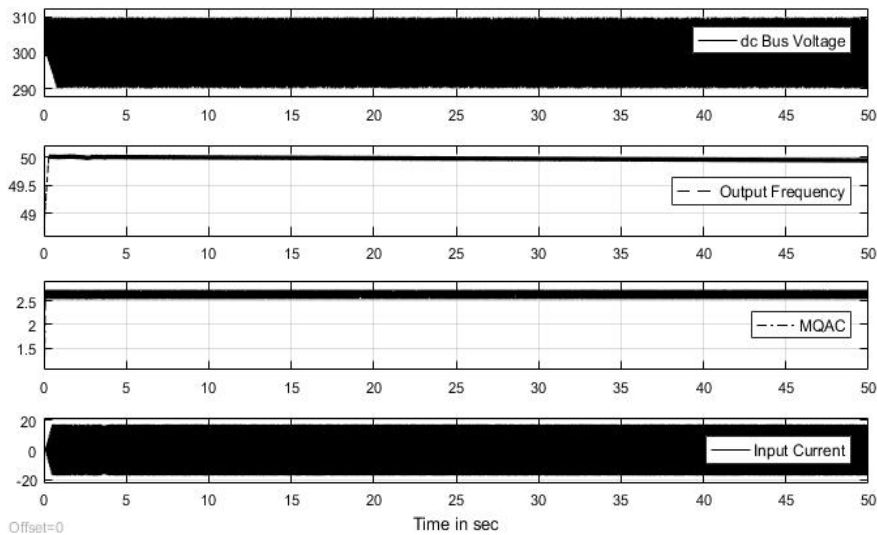

Fig. 12 Simulation results of proposed ANFIS controller for 50sec. output frequency and M-QAC

Table 2 Comparison results using various techniques

Steady State Values	I_{INPUT} (RMS)	I_{INPUT} (Peak-to-Peak)	V_{dc} (Peak-to-Peak)	P_{OUTPUT}	Motor Speed (Per Unit)
q-axis average current method [13]	4.3 A	30.5 A	23.5 V	0.31 hp	0.81
DC bus voltage method [13]	5.7 A	39.9 A	28.8 V	0.47 hp	0.94
q-axis ripple current method [13]	4.9 A	34.1 A	25.3 V	0.37 hp	0.86
STP-PSO [17]	3.9 A	28 A	21.5 V	0.29 hp	0.75
TRC method [17]	4.1 A	28.5 A	22.5 V	0.3 hp	0.8
ANN controller[20]	3.2 A	24.3 A	19.4 V	0.22 hp	0.59
FLC system	3.5 A	26.3 A	20.2 V	0.26 hp	0.62
ANFIS controller	3 A	22.1 A	16.8 V	0.20 hp	0.5

5. Conclusion

In this paper, ANFIS based efficient controller was designed to solve the common problems presented in the NNs and fuzzy systems with efficient training. The proposed work can effectively reduce the various types of stresses presented in the VFD, which include DC bus capacitors, input side diodes, and terminal block respectively. The proposed approach also reduces the harmonics in current and torque ripples. This increases the system performance even though unexpected changes occurred in the load and speed. By using the proposed ANFIS control approach, the excessive stresses on the AC motor and unwanted components are effectively mitigated to improve the additional performance of the VFD. The proposed method also achieved the VFD with the maximum possible optimization. The proposed control system focuses primarily on making the add-on safe for drives, when operated in a single phase. Thus, the same power derating drive's reliability and lifetime was improved in a progressive way compared with the drives operating under the dc-bus-voltage-ripple based protection. A fuzzy critic was utilized to further improve the controller performance. It is achieved by using the learning of NNs method instead of the standard back propagation-based learning method. The proposed controller performance was compared with the traditional fuzzy controller for effective disturbance rejection and disturbance rejection of a six-switch inverter VF drive respectively. The simulation results of the proposed method are compared with several litterateurs and obtained better performance. The summary of the test results performance are as follows;

- ANFIS controller shows improved steady state and transient responses compared to the ANN controller in complete speed range.
- It is easy to implement compared to the other neuro-fuzzy controllers presented in various literature. as the proposed method utilizes 9 rules, 4 layers and 18 neurons only.
- It does not need an accurate IM model, its interface description and knowledge representation are moderately easy, and thus its implementation and construction is much easy.
- It does not require the presence of an expert person to achieve the best fuzzy set rules, it automatically sets those rules as it contains the only few adjustable parameters involved in the entire system. Thus, the proposed ANFIS controller can effectively control the wide range of nonlinear and complex systems.
- For practical applications, extend the controller to meet the more effective fuzzy rules. Thus the furthermore performance, reliability and lifespan in real time hardware systems can be achieved.

Acknowledgement

Communication of this paper is made possible through the assistance of Mahesh Swamy, Chief Engineer, R&D Yaskawa America Inc. that greatly improved the manuscript.

Conflict of Interest

Authors declare that there is no conflict of interests regarding the publication of the paper.

Author Contribution

The authors confirm contribution to the paper as follows: **study conception and design:** Rekha Mudundi, Malligunta Kiran Kumar; **data collection:** Rekha Mudundi; **analysis and interpretation of results:** Malligunta Kiran Kumar, Rekha Mudundi; **draft manuscript preparation:** Rekha Mudundi. All authors reviewed the results and approved the final version of the manuscript

References

- [1] E Ramakrishna and Vinay Kumar. Anfis based grid connected solar pv based water pumping using bldc motor drive. *Industrial Engineering Journal*, 52:2293–98, 2023.
- [2] Khusro Khan, Saurabh Shukla, and Bhim Singh. Single-phase grid-fed variable frequency high-efficiency induction motor drive for fan applications. *IET Energy Systems Integration*, 4(1):54–71, 2022.
- [3] Saurabh Shukla and Bhim Singh. Reduced-sensor-based pv array-fed direct torque control induction motor drive for water pumping. *IEEE Transactions on Power Electronics*, 34(6):5400–5415, 2018.
- [4] Chandra Sekhar et al. Implementation of zero current switch turn-on based buck-boost-buck type rectifier for low power applications. *International Journal of Electronics*, 106(8):1164–1183, 2019.
- [5] L Sri Sivani, L Nagi Reddy, BK SubbaRao, and A Pandian. A new single switch ac/dc converter with extended voltage conversion ratio for smps applications. *Int. Journal of Innovative Technology and Exploring Engineering*, 8(3):68–72, 2019.
- [6] E. C. dos Santos, et al. "Single- phase to three-phase power converters: State of the art," *IEEE Transactions on Power Electronics*, vol. 27, no. 5, pp. 2437–2452, May 2012.
- [7] M. Lazic, et al., "Designing of multiphase boost converter for hybrid fuel cell/battery power sources," in *Paths to Sustainable Energy*, J. Nathwani and A. Ng, Eds. Rijeka, Croatia: InTech, Dec. 30, 2010.
- [8] Y. Jang and M. M. Jovanic, "A bridgeless PFC boost rectifier with optimized magnetic utilization," *IEEE Transactions on Power Electronics*, vol. 24, no. 1, pp. 85–93, Jan. 2009.
- [9] Sontake, Vimalchand & Kalamkar, Vilas. Solar photovoltaic water pumping system - A comprehensive review. *Renewable and Sustainable Energy Reviews*. 59. 1038-1067. 10.1016/j.rser.2016.01.021,2016.
- [10] M. Swamy and C. Guddanti, "An improved single-phase active front end rectifier system for use with three-phase VFDs," in *Proc. IEEE Applied Power Electronics Conference and Exposition*, pp. 1558–1564, 2014.
- [11] Bellamkonda, Prgathi & Devi, Sanam & Ayaz, Nadir & Asker, Mehmet Emin & Malla, Priyanka & Ganesh, Siva & Mohana, Jagan & Malla, Rao & Hossain, Md. Modified Grey Wolf Optimization Algorithm for PV Fed Water Pumping System Driven by Switched Reluctance Motor under Partial Shading Condition, 10.1109/PEDES56012.2022.10080719,2023.
- [12] H. Schultz, "Method and system for improving pump efficiency and productivity under power disturbance conditions," U. S. patent 7,330,779 b2, Feb. 12, 2008.
- [13] Ismail, Bouyakoub & Taleb, R. & Mellah, Hacene & Abdelaziz, Zerglaine. Implementation of space vector modulation for two level three-phase inverter using dSPACE DS1104. *SSRN Electronic Journal*, 0.2139/ssrn.3918716,2020.
- [14] M. Swamy, "An improved single-phase active front end rectifier system for use with three-phase VFDs," U.S. Patent Applications, Jan. 2013.
- [15] Mahesh M. Swamy, et al., "Getting the Most from Variable Frequency Drive: The Optimal Way to Improve Lifetime and Reliability", *IEEE Industry Applications Magazine*, vol. 22, no. 6, pp. 57-65, 2016.
- [16] A. Mora, A. Orellana, J. Juliet and R. Cardenas, "Model Predictive Torque Control for Torque Ripple Compensation in Variable-Speed PMSMs", *IEEE Transactions on Industrial Electronics*, vol. 63, no. 7, pp. 4584-4592, 2016.
- [17] L.Zhang and X. Zhuan, "Optimization on the VFDs Operation for Pump Units", *Water Resource Management*, vol. 33, pp. 355-368, 2019.
- [18] Rajan Kumar and Bhim Singh. Single stage solar pv fed brushless dc motor driven water pump. *IEEE Journal of Emerging and Selected Topics in Power Electronics*, 5(3):1377–1385, 2017.
- [19] M.Rekha, M.Kiran Kumar "Variable frequency drive optimization using torque ripple control and self-tuning PI controller with PSO" , *International Journal of Electrical and Computer Engineering (IJECE)*, Vol.9, No.2, April 2019, pp. 802~814,ISSN:2088-8708,DOI: 10.11591/ijece.v9i2.pp.802-814.
- [20] S Sashidhar, V Guru Prasad Reddy, and BG Fernandes. A single-stage sensorless control of a pv-based borewell submersible bldc motor. *IEEE Journal of Emerging and Selected Topics in Power Electronics*, 7(2):1173–1180, 2018.
- [21] J. Barbosa, J. Correia, R. Júnior and A. Jesus, "Fatigue life prediction of metallic materials considering mean stress effects by means of an artificial neural network", *International Journal of Fatigue*, vol. 135, p. 105527, 2020.

- [22] Yaser Nabeel Ibrahim Alothman, Wisam Essmat Abdul-Lateef, and Sabah Abdul-Hassan Gitaffa. Using sensorless direct torque with fuzzy proportional-integral controller to control three phase induction motor. *Bulletin of Electrical Engineering and Informatics*, 12(2):738–748, 2023..
- [23] M.Rekha, M.Kiran Kumar “Optimization of single phase fed three phase VFD using ANN” , *International Journal of Engineering and advanced Technology*, Vol.9, No.1, July 2019, ISSN: 2249 -8958, DOI: 10.35940/ijeat.A3003.109119.
- [24] H Maammeur, A Hamidat, L Loukarfi, M Missoum, K Abdeladim, and T Nacer. Performance investigation of grid-connected pv systems for family farms: case study of north-west of algeria. *Renewable and Sustainable Energy Reviews*, 78:1208–1220, 2017.
- [25] François Yonga, Colince Welba, Theodore Louossi, and Noël Djongyang. A new control approach of a three-phase inverter two levels. *Open Journal of Energy Efficiency*, 11(3):55–70, 2022.