



# Design Analysis of Bicycle Brake Disc for Carbon Fibre - Lightweight Material

Nida Naveed\*, Michael Whitford

Faculty of Technology, School of Engineering,  
University of Sunderland, St Peters Campus, St Peters Way, Sunderland, SR6 0DD, UK

\*Corresponding Author

DOI: <https://doi.org/10.30880/ijie.2019.11.08.010>

Received 2 July 2019; Accepted 25 November 2019; Available online 15 December 2019

**Abstract:** Disc brakes are becoming a popular choice on cycles, disc brakes provide greater control of braking application and greater reliability, particularly in wet conditions. The transportation industry has seen many advances in material used over the decades, with the aim of reducing weight whilst maintaining or increasing strength and thermal properties. The study looks at the advantages of the lightweight composite materials used to develop the disc brakes for the bicycle applications with the primary aim of weight reduction. The strength to weight ratio as well as heat dissipation is analysed and compared to brake disc materials already widely used in cycling, therefore the material choice and design of disk is of importance. Research established heat dissipation and strengthening techniques in current use, from this, six designs are created. One of which closely matching a currently available brake disc, the purpose of this is to create a benchmark for the analyses. The three materials identified for the use in the brake disc designs are stainless steel, titanium and carbon fibre. Results showed that significant weight saving can be achieved when using low density material-carbon fibre. Stress (Von Mises) and displacement equalled or improved upon standard stainless-steel brake discs. Thermal analysis showed that carbon fibre is able to achieve good levels of heat dissipation, without the need of extra cooling features. It is determined that a road going bicycle brake disc can be up to 70% lighter when carbon fibre is used in conjunction with the design best suited for the material.

**Keywords:** Disc brake, Bicycles, lightweight materials, carbon fibre, stainless steel, titanium.

## 1. Introduction

Disc brakes provide a more efficient and reliable braking experience in bicycling applications [1]. However, historically, cycles lag behind in vehicle industry in terms of the use of modern technological advances. Brake discs are widely used in the automotive industry. Disk brakes have become a popular alternative to traditional rim braking, however, these systems rely on metal discs [2], [3]. A wide variety of materials have been used in the production of brake discs, the most popular within the automotive industry has been grey cast iron [4], [5]. Iron has been a popular choice due to the excellent thermal conductivity properties, enabling the heat generated during braking, to dissipate effectively. The low cost and ease of availability of grey cast iron make this material a continued popular choice. Extensive research has been undertaken on lightweight brake disc materials for the automotive industry, where weight reduction in some instances is up to 50% [6], [7]. The choice of cast iron for motor vehicle brake discs is not particularly useful for the use in cycles, this is due to the weight of the material, however there are several alternatives used within the automotive industry, that may transfer over. Titanium Alloys, Carbon Fibres, Aluminium metal matrix composite (AMC) and Carbon Ceramic have been investigated for motorcycles [8] and these materials can be of benefit in cycling. The use of brake discs systems in cycling is now becoming mainstream, gradually replacing the rim brake systems [9]. Due to the demands of rough terrain, mountain bikes where the first to adopt a disk brake system. Hybrid bikes and more recently, road bikes are utilising disc brake systems as standard. The design of bike calliper systems has been through many revisions and improvements, but the materials used in the disc have largely, remained the same.

\*Corresponding author: [Nida.Naveed@sunderland.ac.uk](mailto:Nida.Naveed@sunderland.ac.uk)

2000 UTHM Publisher. All right reserved.  
[penerbit.uthm.edu.my/ojs/index.php/ijie](http://penerbit.uthm.edu.my/ojs/index.php/ijie)

The typical material used in cycling brakes is stainless steel due to the known advantageous properties, when used in a cycling braking system, for instance, readily available materials and processing facilities. Drawbacks are also evident, for instance, a high density in comparison to other materials and the ability of heat dissipation lags behind other materials [10]. Weight reduction is the most critical consideration in the design and production of cycles. Some studies discussed the materials used in the frame of a bike [11], [12]. However, limited research has been carried out on the use of alternative materials for the bicycle brake disc itself.

## 1.1 Brake disc materials

Stainless steel proves to be a good material for bicycle brake discs due to the ease of availability and high strength to weight ratio [10], [13]. Steel can be shaped to provide greater strength, however at the cost of thermal conductivity [14], [15]. As bike technology advances, it is important to look at which materials may perform better. In motorcycle and bicycles, martensitic stainless steel is used. Stainless steel is a family of corrosion and heat resistant steels [16]. Depending upon the manufacturer, these can have a high or low carbon content. The majority of the composition is type 410 iron with a 12 to 15% addition of chromium. With the addition of carbon, the alloy can be hardened and heat treated, which is beneficial when in use as a brake disc. In an annealed state, the tensile yield strength is around 275 MPa, a high carbon content dictates the strength and hardness of the alloy but also has an impact on ductility and toughness [17]. Ductility can be an issue in certain conditions, for example a hard impact on the metal, sudden failures can occur. This can pose a serious safety hazard as stopping the bike effectively can become difficult [18]. Greater thermal strain in stainless steel is evident in comparison to titanium and carbon fibre [8]. To alleviate this, the disc is designed in such a way to dissipate the heat build-up faster. On the other hand, titanium alloy has a major advantage of the weight reduction, up to 37% of weight can be saved in comparison with the same design of standard cast iron disc [19]. In addition to this, titanium can handle extremes of temperature whilst maintaining high strength [8]. Titanium alloys have long been used in the aeronautical field due to the superior mechanical properties. Titanium alloy performs excellent with regards to brake fade, the effect of brake fade on a varying range of titanium alloys have been analysed and it found that the friction coefficient between the brake pad and disc remained stable whilst the operating temperature increases [19]. Titanium shows wear and corrosion resistance similar to grey cast iron, the wear resistance of titanium alloys can be increased up to the 16% and 30% by adding hard particles. However, the cost of Titanium is higher due to the machining required to form the product [20]. Lightweight material Carbon fibre has long been used for many components in the automotive, aeronautics and bike industry [21], [22], [23]. This is due to the very high strength to weight ratio. Carbon fibre has been examined for the application of car manufacturing and significant weight saving is achieved whilst structural integrity is maintained [24]. The use of carbon fibre in brake disc production is a relatively new concept, some research has been carried out for the use on motorbikes, where promising data was gathered. It has been investigated that the thermal stress and strain on a brake disc in carbon fibre is less than that of stainless steel. In the same instance, the weight of the carbon fibre disc was 75% less than the stainless steel disc [8]. In summary, stainless steel and titanium materials have been used for brake disc design. However, the used of these materials have some pros and cons that need to be addressed. Lightweight material carbon fibre can be a great choice due to the very high strength to weight ratio for the application of brake disc manufacturing for motorbikes, but it requires some rigorous research.

## 1.2 Brake Disc Design

An effective design of a bicycle brake disc allows for a brake disc to dissipate heat quickly and effectively without compromise of braking. The design should take into account the surface area required to stop the bike whilst at the same time, keeping weight to a minimum [25], [26]. The effective brake disc is essential for the safety of the rider. Therefore, the design is also incorporate an appropriate factor of safety in accordance with current standards. In addition to this, weight reduction is an essential criterion in bike design, every component is scrutinised for methods of cutting mass [27]. Weight reduction can be achieved in many ways, however, the idea of using lower density stronger materials is a key area. Manufacturers also strive to use minimal material whilst maintaining strength and a suitable brake clamping surface area. One of the main requirements for the brake disc design is effective heat dissipation [28]. It can be optimised in two main ways, firstly selection of a material which can quickly dissipate the heat into the atmosphere. A material with good thermal conductivity helps absorb then release the heat into the atmosphere [29] such as Carbon fibre. It has a key advantage in heat dissipation, allowing the heat generated to be dispersed quickly, this negates the need for drilled holes and grooves [30]. Secondly, ventilation of the disc can be aided by drilled holes and grooves. The drill patterns and grooves vary greatly between manufacturers. Carbon fibre relies on a specific method of production to maximise its strength [31]. Depending upon the layup technique used, its strength may be evident in one direction only. The method of mounting the disc to the hub of the bike needs to be taken into consideration. There are two main standards when it comes to mounting techniques [32] details are given in Table 1.

**Table 1 - Methods of mounting the disc to the hub of the bike.**

The international six bolt method	The Shimano spline type - A
Six Torx bolts are mounted to the corresponding bolt locations on the hub. The advantages of this setup are, compatibility with most setups and ease of maintenance, no special tools are required. The disadvantages are, bolt thread damage during installation/removal and difficulty in disc to hub alignment. Fig. 1(a) shows the international six bolt method.	Splined fitting mounts onto the hub, the hub matches the spline pattern, effectively locking the disc into place. The advantages are, ease of installation and removal and perfect alignment to hub. The disadvantages are a heavier disc and a special tool is required for removal [33] Fig. 1 (b) shows the spline type fitting.



**Fig. 1 - The method of mounting the disc to the hub of the bike – (a) A SRAM Centerline rounded 6-hole brake disc and (b) A Shimano SM-RT54 Centerlock disc.**

The brake pads play a vital role to generate the friction that needed for stop the bike. There are two main types of brake pad, semi metallic and sintered, the former consists of a blend of metal chips and organic matter. This arrangement provides the friction needed and a path for heat dissipation. The latter (sintered), is a more complex arrangement required for stainless steel and carbon fibre discs. This is a mix of metallic powders and refractory material. The refractory material provides the friction required whilst the metal dissipates the heat build-up. The sintering process mixes the materials to form the brake pad. One main area of benefit is in wet conditions. Since the pads have greater porosity, they are better able to remove the water off the surface of the stainless-steel disk, increasing braking efficiency. The sintered brake pads are used for this study.

The brake disc should design in a way that can allow heat to dissipate effectively, whilst retaining disc aerodynamic properties and reducing the risk of brake fade. Therefore, the study intends to design of bicycle brake discs, incorporating the use of alternative lightweight material that has a greater strength to weight ratio than traditional metallic discs and that can withstand high friction over the expected disc lifecycle. In this study, the computer aided simulations are used to accurately determine the validity of alternative materials on several brake disc designs featuring commonly used methods of cooling, strengthening and weight saving. In this study, the six designs of disc brake are created, and these designs are analysed and evaluated using three different materials. In the study, the stress-strain and thermal analysis are performed using the software and Finite Element Analysis (FEA) and compare the findings to traditional metallic discs. This provides comparative data between pre-existing design and material combinations and the new designs that are introduced in the study.

## 2. Design considerations

The forces acting upon a bicycle brake disc change greatly during a typical ride out, ranging from light prolonged application to heavy short application. To ensure accuracy when analysing the brake discs, several assumed factors are set out according to the industry standard [34] as follows:

- A 600 mm<sup>2</sup> circular brake pad profile is used as per current industry standard.
- The value of coefficient of friction between the brake disc and sintered pad is considered as constant to perform effective analysis for each material. The standard value of coefficient of friction is in between 0.35 to 0.42 for bike disc application [35]. The midpoint value of 0.39 is taken for the analysis.
- Each disc is designed using the standard six bolt method.
- For the brake disc design, the outer diameter is 180mm, the inner diameter is 145mm and the thickness of the disc is 1.5mm are taken according to the industry standard.
- It is considered that the braking is occurred on an even and flat surface, composed of asphalt. The coefficient of friction between the bicycle tyre (standard rubber composition) and the asphalt is taken as 0.8.
- The bicycle wheel diameter is taken as 622mm, the width of the rim is 25mm according to the industry standard for a road bicycle.

### 3. Calculation of Forces Acting upon the Disc

The calculations set out in this session are used to determine the forces that are applied on the brake discs to perform the analysis.

#### (a) Maximum Braking Force Calculation

The maximum pressure is exerted between the brake disc and pad before the traction between the tyre and tarmac is lost (skid condition). Therefore, the equation 1 can be used to calculate the force required before traction is lost. For the calculation, the mass of the rider and bike is considered as 90 kg and the bicycle will be brought to a complete stop from a velocity of 45km/h (12.5m/s) in 3 seconds. In equation 1,  $F_{TYRE}$  represents a Force at point of loss of traction (N),  $M$  is for total mass (Kg),  $g$  is for gravity (m/sec<sup>2</sup>) and  $u_r$  represents Coefficient of friction. Deceleration can be calculated from equation 2.

$$F_{TYRE} = M \cdot g \cdot u_r \quad eq(1)$$

$$F_{TYRE} = 90 \times 9.81 \times 0.8$$

$$F_{TYRE} = 706 \text{ N}$$

$$Deceleration (a) = \frac{Initial\ velocity (u) - Final\ velocity (V)}{Time\ taken (t)} \quad eq(2)$$

$$a = \frac{12.5}{3}$$

$$a = 4.16 \text{ m/s}^2$$

The braking force applied during analysis is 706 N. This is the point in which the tyre will begin to lose traction, therefore the point at which maximum force is exerted. A greater force will cause the brake disc and pad to lock, at which point the torque will be nil and the disc will be free from stress and strain. To calculate the maximum pressure, a force marginally below from  $F_{TYRE}$ , therefore the value of force ( $f$ ) is 705 N can be used in the equation 3.

$$Pressure (P) = \frac{Force (f)}{Area (A_{PAD})} \quad eq(3)$$

$$P_1 = \frac{705}{600 \times 10^{-6}}$$

$$P_1 = 1.18 \text{ MPa}$$

The brake torque ( $T_1$ ) is calculated using the equation 4 and equation 5. In this equation,  $R_i$  represents the inner radius of the brake pad from the centre of the disc (90mm),  $R_o$  is for The outer radius of the brake pad from the centre of the disc (72.5mm) and  $R_M$  represents The mean radius of the brake pad from the centre of the disc.

$$R_M = \frac{R_o + R_i}{2} \quad eq(4)$$

$$R_M = \frac{90 + 72.5}{2}$$

$$R_M = 81.25 \text{ mm}$$

$$Torque (T) = Force(f) \times Brake\ Pad\ Effective\ Radius (R_m) \quad eq(5)$$

$$T = 706 \times 81.25 \times 10^{-3}$$

$$T_1 = 57.36 \text{ N m}$$

#### (b) Energy Conversion

The value of kinetic energy and braking power are required to calculated to perform brake disc heat dissipation analysis during dynamic braking. The temperature of the disc surface is generally the measure of braking performance [8]. Brake fade is of concern, leading to vastly reduced braking performance, therefore peak temperature is taken into account. The kinetic energy can be calculated using the equation 6.

$$Kinetic\ Energy (K_E) = \frac{1}{2} \times Mass (M) \times Velcoity^2 (V) \quad eq(6)$$

$$K_E = \frac{1}{2} \times 90 \times 12.5^2$$

$$K_E = 7031.25 \text{ Joule (J)}$$

The motion energy of the bicycle is dissipated within the braking system, the majority of the energy is converted to heat, the measurement of this process is braking power. Equation 7 can be used to calculate braking power.

$$Power (P) = \frac{Energy (K_E)}{Time (t)} \quad eq(7)$$

$$P = \frac{7031.25}{3}$$

$$P = 2343.75 \text{ Watt (W)}$$

#### 4. Material Properties for the Design

The material properties of the three chosen materials for the design of the discs are shown in **Error! Reference source not found.**. The properties are taken from CES Edupack 2018.

**Table 2 - Shows properties of the chosen materials [36]**

Mechanical Properties	Stainless Steel 410	Titanium 6Al-4V (Ti-6Al-4V)	Epoxy/HS Carbon Fibre, UD Prepreg, UD Layup
Density (Kg/m <sup>3</sup> )	7.65x10 <sup>3</sup>	4.41x10 <sup>3</sup>	1.55x10 <sup>3</sup>
Youngs Modulus (Gpa)	190	110	129
Yield Strength (Mpa)	1000	827	1740
Tensile Strength (Mpa)	1250	896	1740
Shear Modulus (Gpa)	73	43	3.74
Toughness (Kj/M <sup>2</sup> )	10.7	59.7	25.5
Max Service Temperature °C	357	350	140
Min Service Temperature °C	-150	-273	-123
Thermal Conductivity Wm.°C	15.6	7.1	0.75
Specific Heat Capacity J/Kg.°C	481	528	902
Thermal Shock Resistance °C	58.4	763	1501
Thermal Distortion Resistance MW/m	0.933	0.788	0.228

#### 5. Designs of the Discs

All together six brake disc designs are drawn up according to the industry standard dimensions. Solidworks software is used to create all these geometries. Brake disc design six has been used as the benchmark, the design closely matches an existing disc on the market as shown in Fig. 2. This provides comparative data between pre-existing design and the new designs that introduced in this study.

**Table 4** shows the geometry of the six designs of brake disc.

#### 6. Brake Disc Mass

The mass of each disc design is calculated for the three materials using the Equation 9. Table 3 displays the volume, density and calculated mass of all disc designs. The design 1 composed of carbon fibre has the lowest mass. However, the design 2 composed of stainless steel has the greatest mass. It is given an indication of the weight saving that lightweight alternative materials can achieve. This data is used in the analysis and discussion sections to determine which design is the most viable option for reducing brake disc weight whilst maintaining strength.

$$Mass (M) = Volume (V) \times Density (\rho) \quad eq(9)$$

**Table 3 - Displays the volume and the mass of each brake disc design.**

Design	Volume (mm <sup>3</sup> )	Density (Kg/m <sup>3</sup> )			Mass (Kg)		
		Stainless Steel 410	Titanium Ti-6Al-4V	Carbon Fibre Epoxy/HS	Stainless Steel 401	Titanium Ti-6Al-4V	Carbon Fibre Epoxy/HS
1	17342.59	7.65x10 <sup>3</sup>	4.41x10 <sup>3</sup>	1.55x10 <sup>3</sup>	0.133	0.076	0.026

2	27573.17	0.211	0.122	0.043
3	19574.71	0.150	0.086	0.030
4	20122.60	0.154	0.089	0.031
5	17660.68	0.135	0.078	0.027
6	18723.02	0.143	0.083	0.029

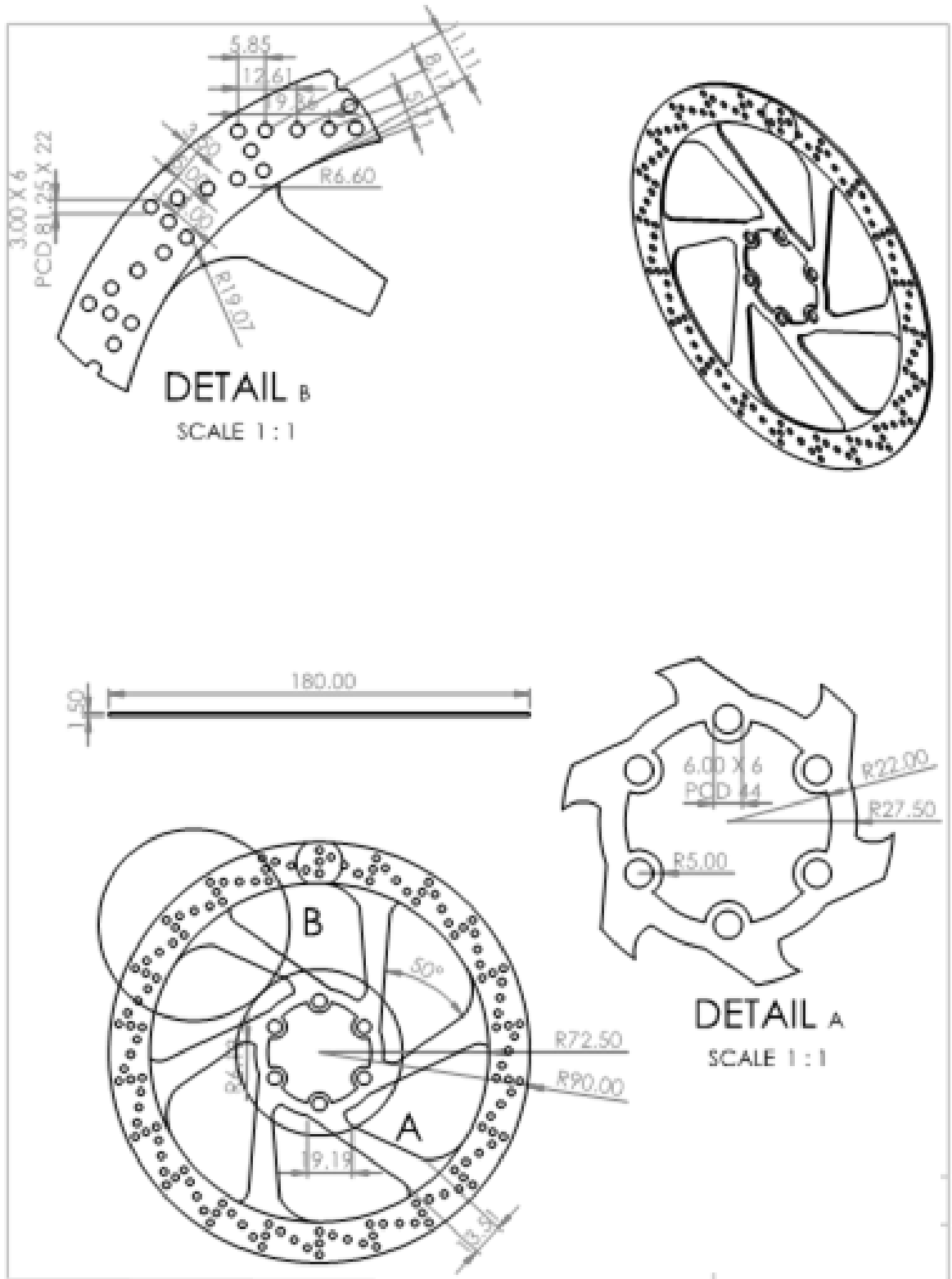
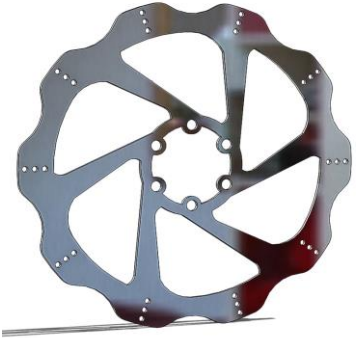
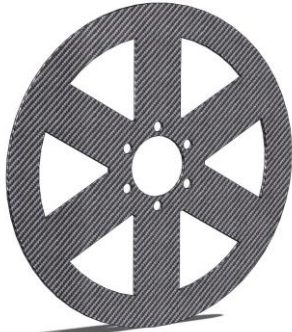

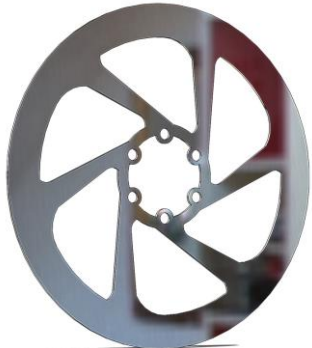
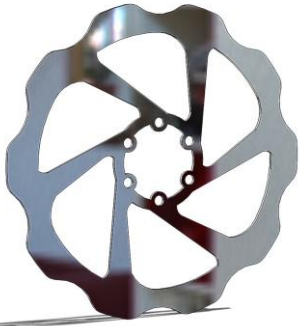
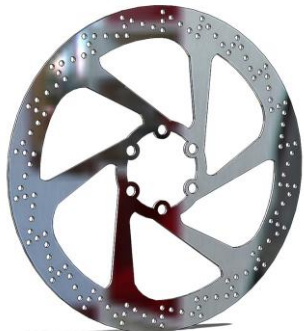


Fig. 2 - Benchmark disc design (design 6), image shows specified standard dimensions (mm).

**Table 4 - shows the geometry of the six designs of brake disc.**

		
<p><i>Design 1: Angled spokes, waived edges and drilled holes.</i> It shows a disc with a waived pattern around the circumference. A greater surface area increases airflow and aids with contaminant removal during braking. Drilled holes increase ventilation. The volume of this disc is 17342.59mm<sup>3</sup></p>	<p><i>Design 2: Material added, no ventilation.</i> It shows the spoke width is increased and ventilation is removed, the increased width increases the overall strength of the disc. A larger amount of material is added around the PCD, decreasing the risk of shear stress. The volume of the disc is 27573.17mm<sup>3</sup></p>	<p><i>Design 3: No ventilation, angled spokes.</i> It shows a disc with thin spokes coming off at an angle, there is no ventilation on the disc. The volume of the disc is 19574.71mm<sup>3</sup></p>
		
<p><i>Design 4: an angled spoke design, no ventilation.</i> The angles increase the strength of the disc in the direction of travel, for example the spokes will move outwards from the centre of the disc when mounted on a bicycle. In this design, the slotted vents are not used to make this a solid disc. The volume of the disc is 20122.60mm<sup>3</sup></p>	<p><i>Design 5: Similar to design 1, ventilation removed.</i> The geometry remains the same with the exception of the removal of ventilation (drilled holes), making it a solid disc. The volume of the disc is 17660.68mm<sup>3</sup></p>	<p><i>Design 6: an angled spoke design, with multiple drilled holes.</i> This design is very close to the existing design. It is an angled spoke design, the angles increase the strength of the disc in the direction of travel, for example the spokes will move outwards from the centre of the disc when mounted on a bicycle. The design features multiple drilled hole pattern to enhance cooling. The volume of this disc is 18723.02mm<sup>3</sup></p>

## 7. Thermal Stress Analysis

Thermal study in SolidWorks 2018 Simulation has been used to study the effect of brake power. Thermal analysis was carried out before the mechanical analysis, this allows for the outcome of the thermal analysis to be used in conjunction with mechanical studies. As the properties of materials change with temperature increase, it is important to analyse the mechanical properties at the high temperatures generated, allowing for more accurate determination of failure. These conditions have been set up for each brake disc simulation. The study was set to transient, with a time period of three seconds and a time step of 0.1 seconds. An initial temperature of the brake disc is applied at 25°C. Convection between the disc surface and surrounding air is set at 90 w/(m<sup>2</sup>k). This simulates a moderate movement of air across the disc surface. The convection coefficient remained at 90 w/(m<sup>2</sup>k) throughout the transient period. A bulk ambient temperature of the surrounding air is set at 25°C, this remained constant throughout the study. Heat power 2343.75 watts is applied to the contact surfaces between the brake disc and pad on both sides (A split line created in the SolidWorks Sketch was used to achieve correct positioning). It remained constant throughout the simulation period, acting as a heavy braking condition. Each model was meshed then in three-dimensional form with a fine mesh, to allow for greater accuracy of results, particularly in areas of the disc where the greatest thermal stress is expected.

## 8. Mechanical Stress Analysis

Using Static Study in SolidWorks 2018 Simulation, all six-disc designs and three materials are analysed in a static state, the fixings and forces applied represents the disc in a heavy or maximum braking conditions. Fixed geometry is applied to the six mounting bolts on the central PCD, this is the area where the disc attaches to the central shaft of the bicycle. Sliding geometry is applied to the area of contact between the brake pad and disc. A split line was created in SolidWorks Sketch to represent the brake pad area. This simulates the interaction between the brake pad and disc. A pressure of 240 MPa is applied in the brake pad area and acting tangentially on both sides of the brake disc surface. A force of 706N is applied in the brake disc orientation of travel acting upon the brake pad contact area, this is on both sides of the disc. The results from the thermal study have been applied, the results are taken from a time period of three seconds (maximum heat generated). The discs are meshed in three-dimensional form, to a fine mesh. This allows for a more accurate analysis of the areas of stress and strain.

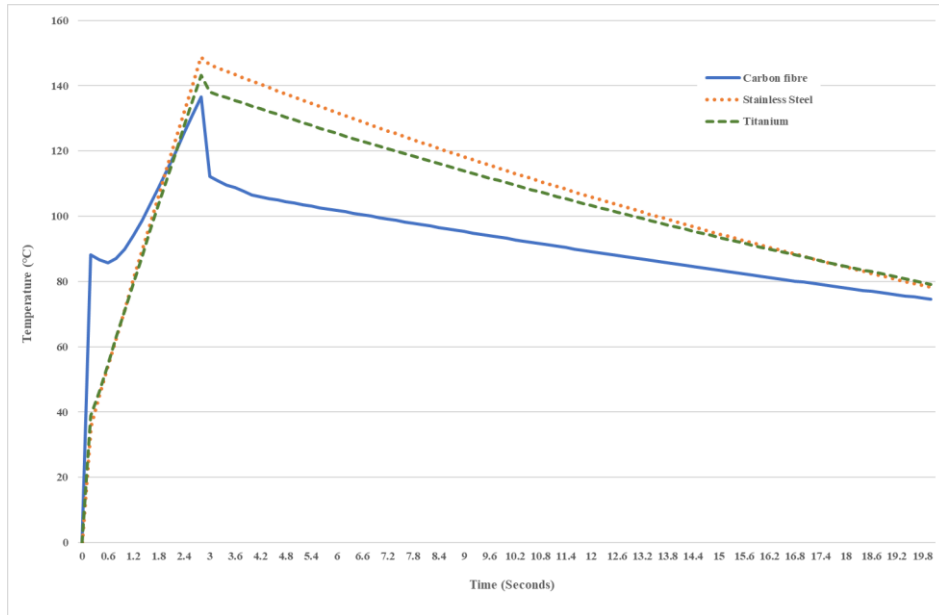
## 9. Thermal Analysis Results

The results of each disc and material combination have been recorded in Table 5, the recorded temperature is the maximum temperature reached during heavy braking. Table 6 shows the images of thermal stress results for all six designs of each material.

**Table 5 - Shows maximum temperature recorded for each brake disc design during transient thermal analysis.**

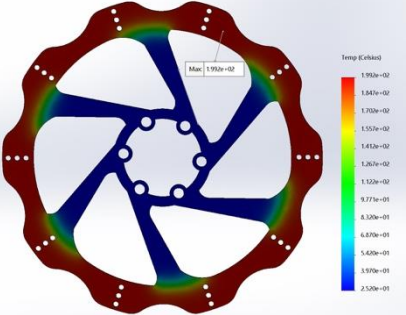
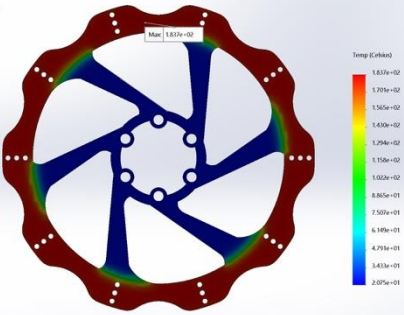
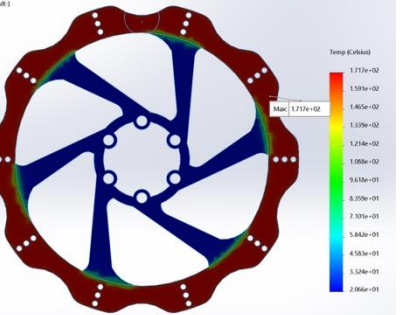
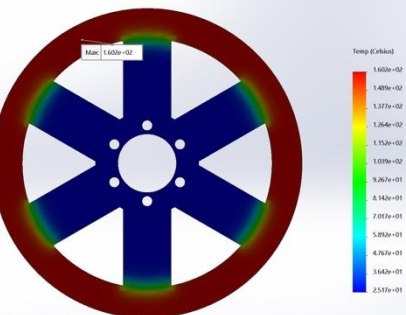
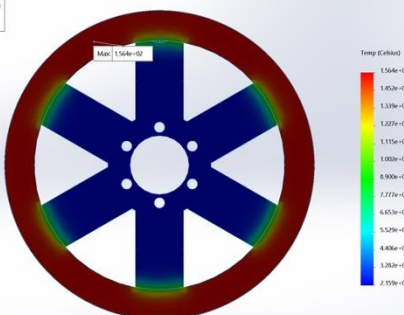
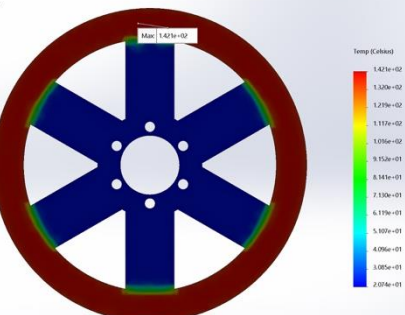
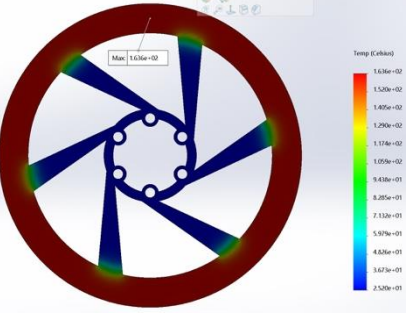
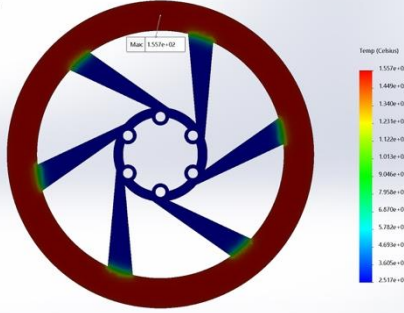
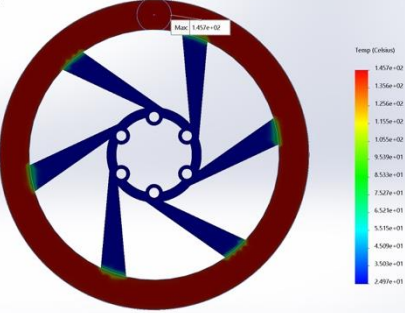
Design	Maximum Temperature Under Heavy Braking (°C)		
	Material		
	Stainless Steel 304	Titanium	Carbon Fibre
1	199	184	172
2	160	156	142
3	164	156	146
4	166	158	146
5	194	184	170

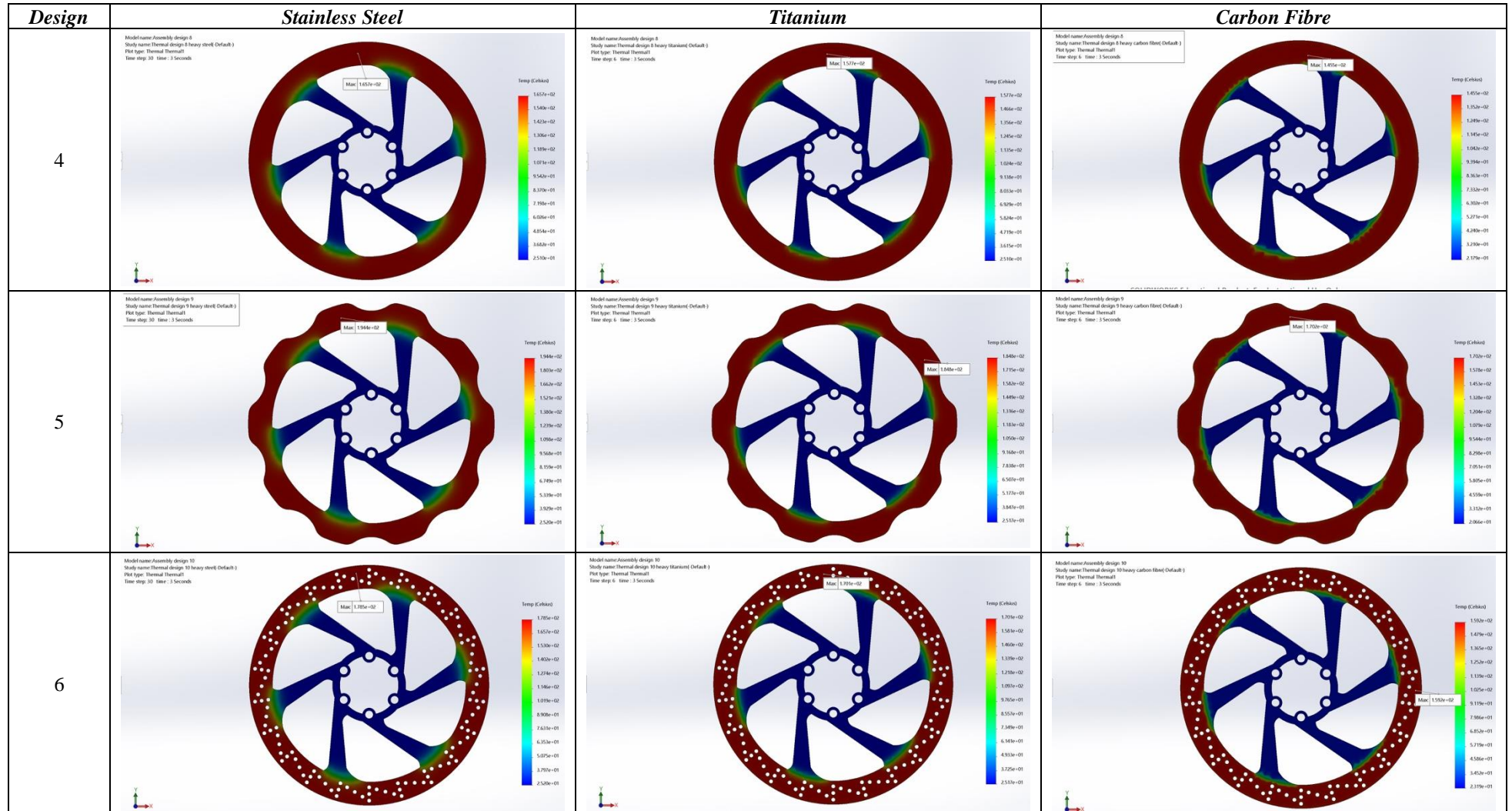




**Fig. 3 - shows cool down period after initial heavy braking for design 2.**

**Table 6: Shows the images of thermal stress results for all six designs of each material.**

Design	Stainless Steel	Titanium	Carbon Fibre
1	<p>Model name: Assembly design.3 Study name: Design.3 Heavy Thermal (steel) (Default) Plot type: Thermal Thermal1 Time step: 30 Time: 3 Seconds</p> 	<p>Model name: Assembly design.3 Study name: Design.3 Heavy Thermal (Titanium) (Default) Plot type: Thermal Thermal1 Time step: 6 Time: 3 Seconds</p> 	<p>Model name: Assembly design.3 Study name: Design.3 Heavy Thermal carbon fibre (Default) Plot type: Thermal Thermal1 Time step: 6 Time: 3 Seconds</p> 
2	<p>Model name: Assembly design.4 Study name: Thermal design.4 Heavy steel (Default) Plot type: Thermal Thermal1 Time step: 30 Time: 3 Seconds</p> 	<p>Model name: Assembly design.4 Study name: Thermal design.4 Heavy Titanium (Default) Plot type: Thermal Thermal1 Time step: 6 Time: 3 Seconds</p> 	<p>Model name: Assembly design.4 Study name: Thermal design.4 Heavy carbon fibre (Default) Plot type: Thermal Thermal1 Time step: 6 Time: 3 Seconds</p> 
3	<p>Model name: Assembly design.5 Study name: Thermal heavy design.5 steel (Default) Plot type: Thermal Thermal1 Time step: 30 Time: 3 Seconds</p> 	<p>Model name: Assembly design.5 Study name: Thermal heavy design.5 Titanium (Default) Plot type: Thermal Thermal1 Time step: 6 Time: 3 Seconds</p> 	<p>Model name: Assembly design.5 Study name: Thermal heavy design.5 Carbon fibre (Default) Plot type: Thermal Thermal1 Time step: 6 Time: 3 Seconds</p> 



### 10. Brake Disc Cooling

An extended study is carried out on design 2 and design 6. The purpose of this study is to determine the cool down period of the disc after heavy braking. Design 2 is chosen due to the larger surface area, without cooling features. Design 6 (benchmark test) is chosen to simulate multiple drilled holes. The study ran for 20 seconds, with an initial three seconds of heavy braking (maximum heat power enabled) followed by 17 seconds of cooling (heat power disabled). Fig. 3 and Fig. 4 show the cool down period for design 2 and design 6.

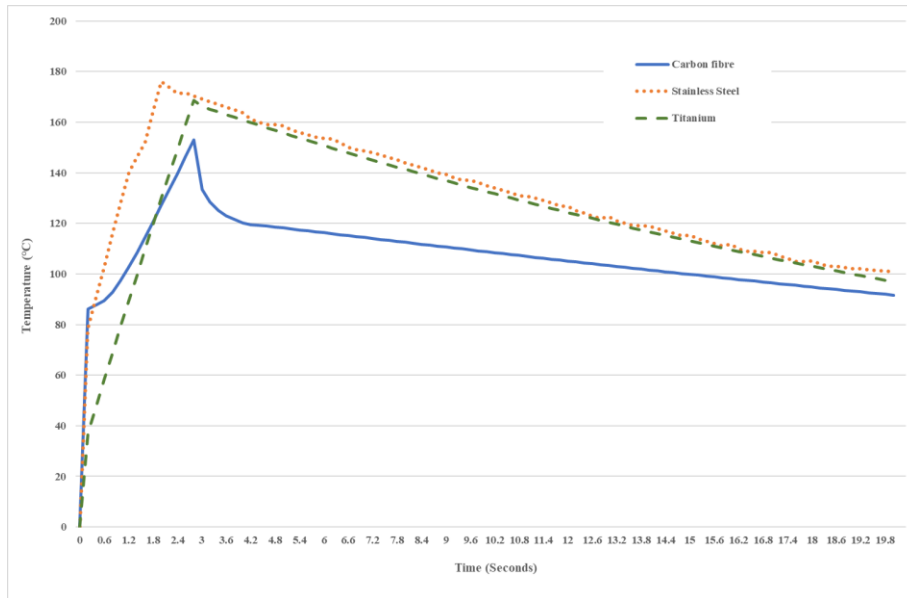


Fig. 4 - shows cool down period after initial heavy braking for design 6.

### 11. Mechanical Stress Analysis Results

Table 7 and Table 9 show the stress (Von Mises) results on each brake disc design and material combination.

Table 7 - Mechanical Stress (Von Mises) results for all disc and material combinations.

Design	Maximum Stress Under Heavy Braking (MPa)		
	Material		
	Stainless Steel 304	Titanium	Carbon Fibre
1	878	322	237
2	425	149	68
3	675	349	230
4	773	296	101
5	895	328	110
6	824	317	142

### 12. Displacement results

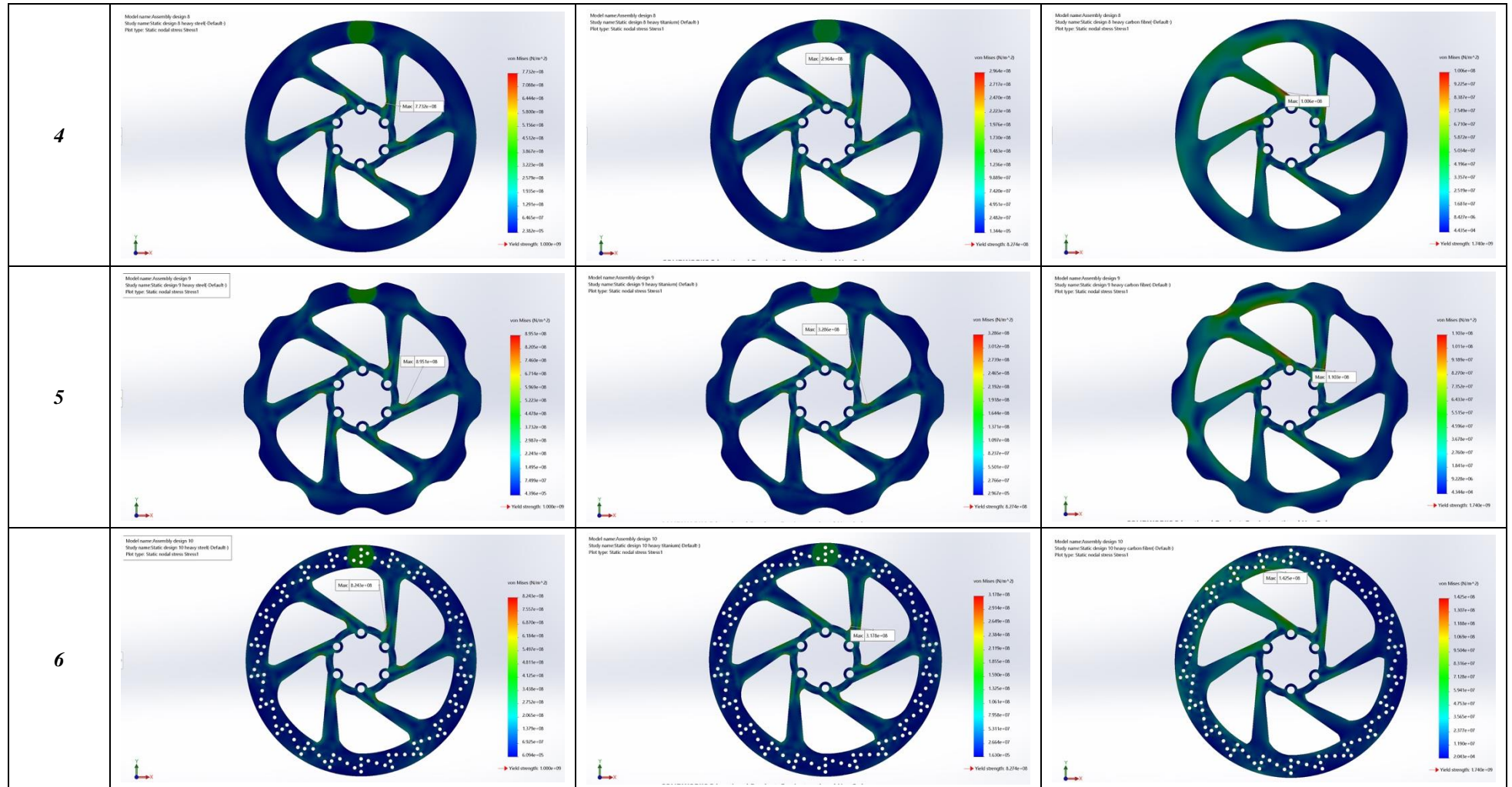
Table 8 and Table 10 display the maximum displacement of all six-disc designs and material combinations. A large displacement introduces chatter and vibration when braking. Throughout all designs, the areas of greatest displacement have been noted on the outer circumference of the disc.

Table 8 - Maximum displacement recorded during static analysis.

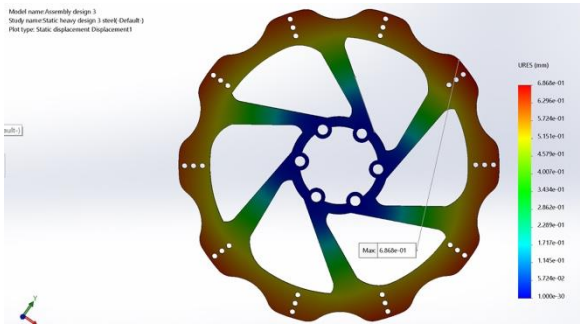
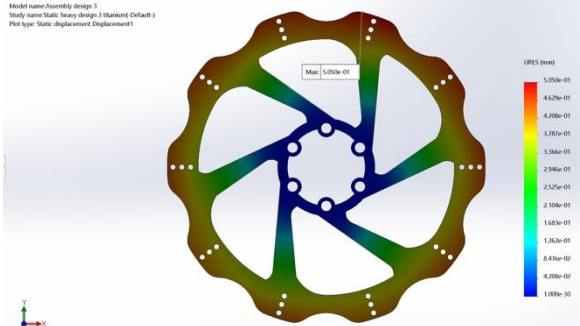
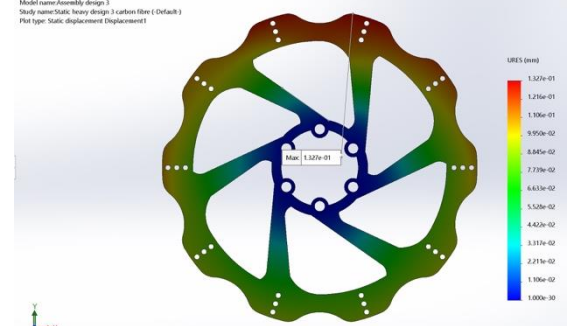
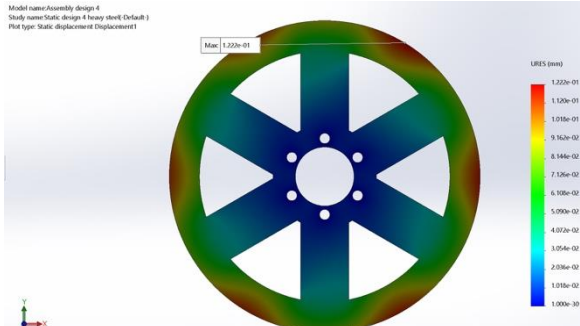
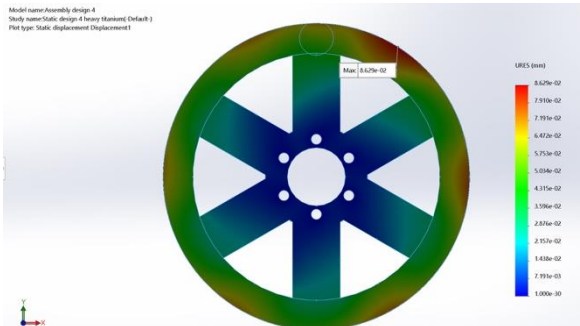
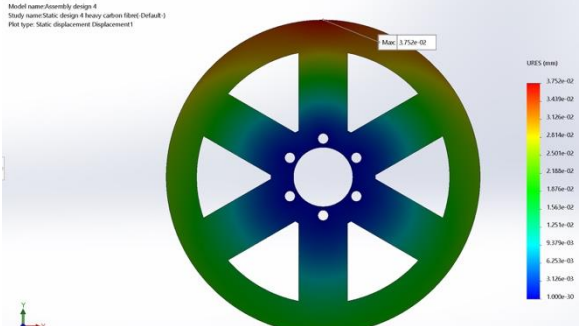
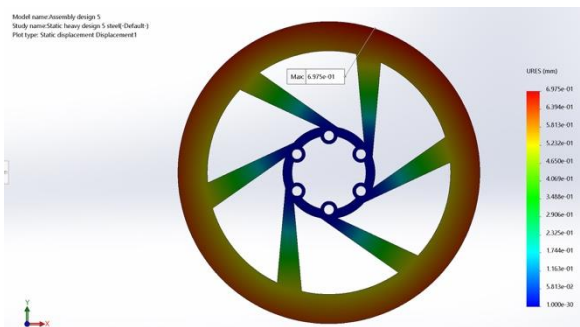
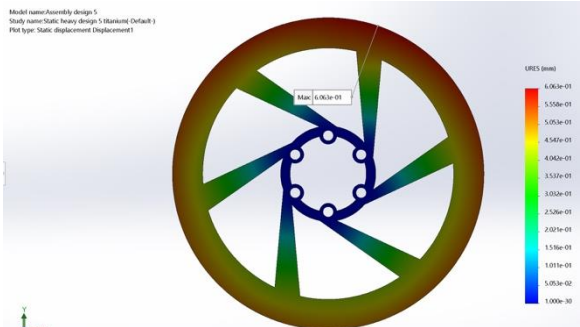
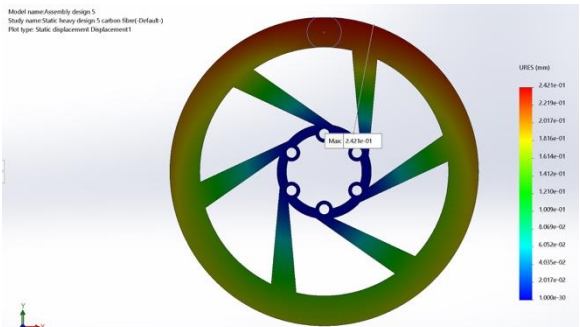
Design	Maximum Displacement Under Heavy Braking (mm)		
	Material		
	Stainless Steel 304	Titanium	Carbon Fibre
1	0.68	0.5	0.13
2	0.12	0.08	0.04
3	0.70	0.6	0.24
4	0.57	0.4	0.11
5	0.67	0.5	0.13
6	0.6	0.45	0.12

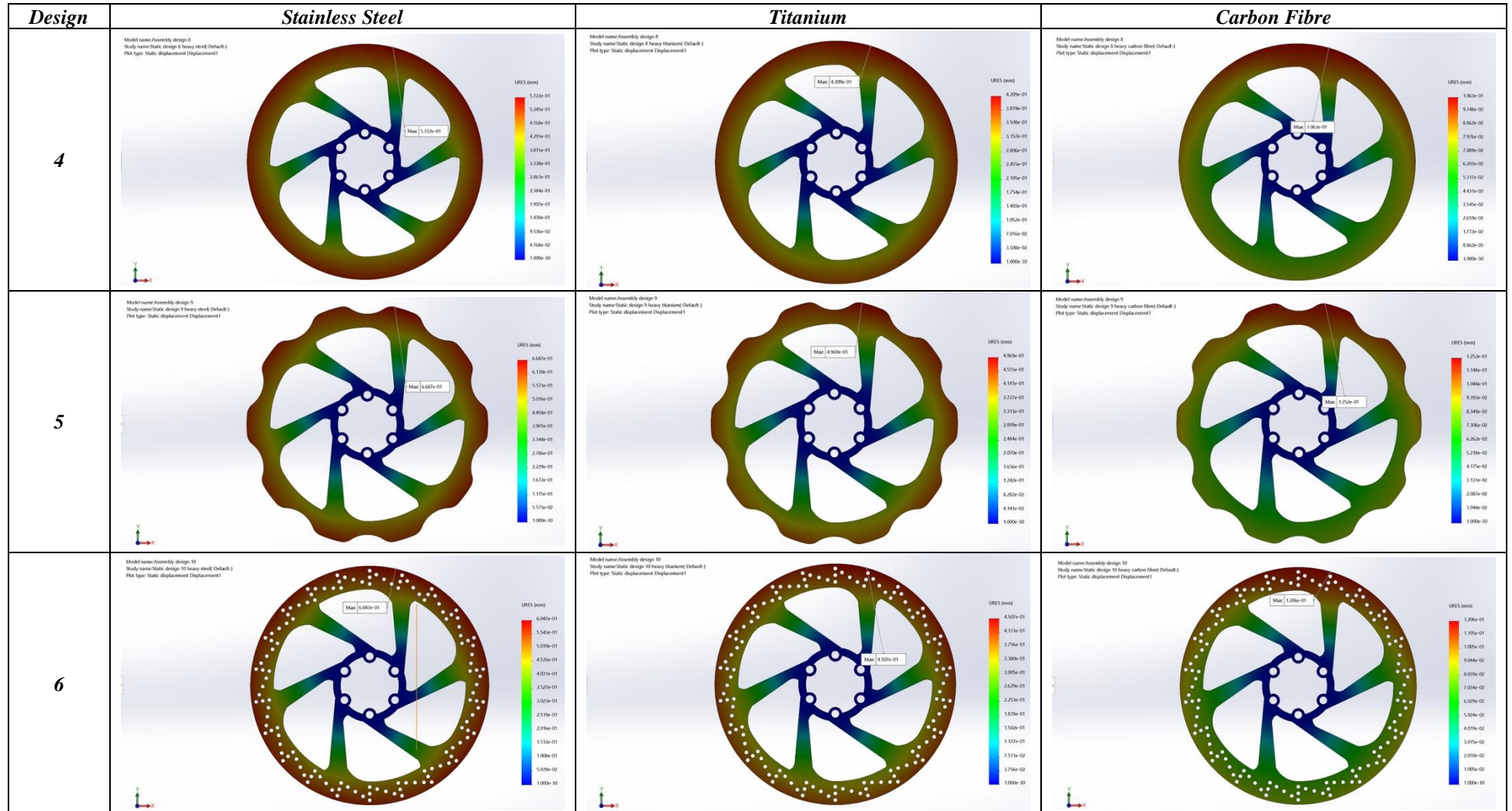
**Table 9 - shows the largest and smallest values of mechanical stresses for all six designs.**

<i>Design</i>	<i>Stainless Steel</i>	<i>Titanium</i>	<i>Carbon Fibre</i>
<b>1</b>			
<b>2</b>			
<b>3</b>			
<i>Design</i>	<i>Stainless Steel</i>	<i>Titanium</i>	<i>Carbon Fibre</i>



**Table 10 - shows the largest and smallest values of displacement for all six designs.**

Design	Stainless Steel	Titanium	Carbon Fibre
1	<p>Model name: Assembly design 1 Study name: Static heavy design 3 (steel) (Default) Plot type: Static displacement Displacement1</p> 	<p>Model name: Assembly design 1 Study name: Static heavy design 3 (Titanium) (Default) Plot type: Static displacement Displacement1</p> 	<p>Model name: Assembly design 1 Study name: Static heavy design 3 (carbon fibre) (Default) Plot type: Static displacement Displacement1</p> 
2	<p>Model name: Assembly design 4 Study name: Static design 4 (heavy steel) (Default) Plot type: Static displacement Displacement1</p> 	<p>Model name: Assembly design 4 Study name: Static design 4 (heavy Titanium) (Default) Plot type: Static displacement Displacement1</p> 	<p>Model name: Assembly design 4 Study name: Static design 4 (heavy carbon fibre) (Default) Plot type: Static displacement Displacement1</p> 
3	<p>Model name: Assembly design 5 Study name: Static heavy design 5 (steel) (Default) Plot type: Static displacement Displacement1</p> 	<p>Model name: Assembly design 5 Study name: Static heavy design 5 (Titanium) (Default) Plot type: Static displacement Displacement1</p> 	<p>Model name: Assembly design 5 Study name: Static heavy design 5 (carbon fibre) (Default) Plot type: Static displacement Displacement1</p> 





### 13. Discussions on results

In this study five new brake disc design concepts were created. The aim of this study was to create a lightweight disc capable of withstanding high temperature and the demands of heavy braking. Research determined that different materials required different methods of strengthening and cooling. Therefore, various designs were modelled to take this into account. Brake disc design six has been used as the benchmark, the design closely matches an existing disc on the market.

Table 6 shows the images of thermal analysis for all six designs of each material and shows the highest recorded temperature. Carbon fibre recorded the lowest maximum temperature throughout all the designs. As the material strength decreases when temperature rises, it is important to incorporate the study into the mechanical analysis.

Fig. 4 shows the cool down period for design 6. It is noted that all material types have a high initial decrease in temperature followed by a long steady period of cooling. Design 6 incorporates multiple drilled holes, despite higher temperatures during braking, a greater temperature difference after braking is recorded in comparison to design 2 (Fig. 3). In both the cases, carbon fibre has a large initial temperature drop-off, followed by an extended period of cooling with a lower difference of that seen by titanium and stainless steel. In the design 6, the highest maximum temperature for carbon fibre is 152°C and lowest maximum temperature is 91°C, a temperature difference of 61°C. In the design 2, the highest maximum temperature is 136°C and lowest maximum temperature is 74°C, a temperature difference of 62°C. This indicates disc brake cooling features have little effect for the material of carbon fibre.

The objective to identify a material with a greater strength to weight ratio than traditional metallic discs have been achieved with the analysis of carbon fibre discs. As the density of carbon fibre is considerably lower, there has been significant weight saving in all six designs. Maintaining high yield strength has also been achieved, particularly with design 2 composed of carbon fibre. The maximum stress is 68 MPa (giving a factor of safety of 25.5), in comparison to stainless steel and titanium at 425 MPa and 149 MPa respectively. Design 2 composed of stainless steel has a weight of 0.211 Kg and carbon fibre has a weight of 0.043 Kg, a weight reduction of 0.168 Kg or 79%. Titanium showed a mid-range result with a weight of 0.122 Kg and stress of 149 Mpa. Design 1 with the material of carbon fibre shows the value of 237 MPa for maximum stress, giving a factor of safety of 7.3. This value is the largest value of maximum stresses in the comparison of all other designs with the same material. Design 2 with the material of stainless steel shows the value of 425 MPa of maximum stress, giving a factor of safety of 2.4. This value is the smallest value of maximum stresses in the comparison of all other designs with the same material. Design 2 with the material of titanium shows the value of 149 MPa of maximum stress, giving a factor of safety of 5.6. This value is the smallest value of maximum stresses in the comparison of all other designs with the same material.

The design of the disc with respect to heat dissipation is analysed, it is noted that a rapid heating of all disc design and material combinations occurred, regardless of cooling methods incorporated into the design. It was also observed that cooling the techniques incorporated into design 6 (drilled holes) are effective at cooling the metallic discs, however, had small effect on the carbon fibre. Carbon fibre is shown to cool at a greater initial pace, then drop off to a lower maximum temperature after the 20 second study. This test is carried out on design 6 (the benchmark) and design 2, the disc with the lowest recorded maximum yield strength. Carbon fibre showed to be better able to dissipate heat without the need of extra machining processes such as drilled holes or slots. Carbon fibre showed consistent desirable results whilst stainless steel largely achieved results consistent of what is expected, as observed in the literature review. Stress was simulated across all six disc designs with three material combinations, It is shown that carbon fibre achieved the better yield strength and stress results. In all tests, titanium gave mid-range results, performing better than steel but not meeting the same level as carbon fibre. Disc design 4 showed to be a viable candidate when titanium is used, with a significant weight saving of 65 grams or 42% over the stainless steel. The disc composed of titanium had a lower maximum stress at 296 MPa in comparison to stainless steel at 773Mpa. The cost of titanium may affect its ability to achieve mainstream production. Further work on the cost of the material and production has been suggested.

It is shown that overall, design 2 composed of carbon fibre is a suitable alternative to a standard stainless steel disc (design 6). Disc design 2 shows a very low displacement at 0.04mm, very low maximum yield strength and has a weight saving of 70% in comparison to current brake disc designs made of stainless steel (design 6). Where all designs in carbon fibre have achieved a greater strength to weight ratio over stainless steel and titanium, research concluded that design 4 has the most suitable composition for carbon fibre. A greater pace of cooling in carbon fibre will help in the reduction of brake fade.

### 14. Conclusion

In this research, multiple brake disc designs are proposed and analysed. Materials suitable for use on a road going bicycle where weight reduction is at the forefront are also investigated. This research exhibits the following conclusions:

- It is noted several designs composed of lightweight materials are capable of withstanding the stress and displacements during heavy braking, however, it is disc design 2 (shown in Fig. 5) that achieved the most desirable results. A weight saving of 70% over the same design composed of stainless steel is observed.

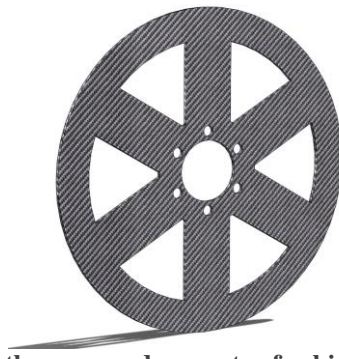


Fig. 5: shows the proposed geometry for bicycle brake disc design

- A suitable material for brake disc construction is identified as epoxy/high strength carbon fibre/unidirectional layup. Research suggested the material has high wear resistance.
- A material with a greater strength to weight ratio than standard stainless-steel discs is determined to be carbon fibre.
- Heat dissipation on all disc designs is analysed, existing methods of cooling is of benefit for the metallic discs. No advantages is noted when cooling methods are incorporated on the brake disc design for carbon fibre.

## Acknowledgement

The authors would like to thank University of Sunderland to provide its support for this research work.

## References

- [1] H. Leitner, (1997). Bicycle disc brake.
- [2] T. J. Mackin *et al.*, (2002). Thermal cracking in disc brakes, *Engineering Failure Analysis*, vol. 9, no. 1, pp. 63–76.
- [3] K. J. Workman and D. W. Pitts, (1995). Method of treating brake pads, US5447035A.
- [4] K. Hampton, (2009). Dual coated cast iron brake rotor and method of construction.
- [5] J. Porkert and W. Lotz, (1999). Optimized gray cast iron plate alloy for utility vehicle brake disks.
- [6] M. A. Maleque, A. A. Adebisi, and Q. H. Shah, (2012). Energy and cost analysis of weight reduction using composite brake rotor, *International Journal of Vehicle Structures & Systems*, vol. 4, no. 2, p. 69.
- [7] N. Naveed, (2019). Design and Analysis of a Disc Brake Rotor for Optimal Performance in Racing, *World Journal of Modelling and Simulation*.
- [8] R. R. Pind, (2016). Analysis and Computational Investigation of Brake Disc for Composite Materials, vol. 4, no. 4, p. 20.
- [9] ‘Full stop: road disc brakes take over in 2018’, *BikeRadar*. [Online]. Available: <https://www.bikeradar.com/features/full-stop-road-disc-brakes-take-over-in-2018/>. [Accessed: 25-Jun-2019].
- [10] K. Shibata, Y. Azuma, M. Inoue, and S. Okumura, (1990). Friction pad for use with disc brake.
- [11] C. Sautter, J. Owen, and D. Condon, (2013). Upright bike mount.
- [12] R. F. Rafoth, (2000). Advanced bike frame design.
- [13] E. F. Buell, (1977). Brake discs.
- [14] ‘Strength-to-Weight Ratio - an overview | ScienceDirect Topics’. [Online]. Available: <https://www.sciencedirect.com/topics/engineering/strength-to-weight-ratio>. [Accessed: 25-Jun-2019].
- [15] N. A. Ahmad, Z. Kamdi, and A. L. M. Tobi, (2018). Wear and corrosion behavior of tungsten carbide based coating on carbon steel, *International Journal of Integrated Engineering*, vol. 10, no. 4.
- [16] S. Tsuge, T. Matsuda, Y. Okada, T. Sakashita, and D. Nago, (2002). Stainless steel for a disc brake rotor.
- [17] ‘Article: Martensitic Stainless Steels’. [Online]. Available: <https://www.bssa.org.uk/topics.php?article=253>. [Accessed: 25-Jun-2019].
- [18] ‘ISSF Martensitic Stainless Steels’, p. 56.
- [19] P. J. Blau, B. C. Jolly, J. Qu, W. H. Peter, and C. A. Blue, (2007). Tribological investigation of titanium-based materials for brakes’, *Wear*, vol. 263, no. 7–12, pp. 1202–1211.
- [20] C.-J. Hu and P.-H. Chiu, (2015). Wear and Corrosion Resistance of Pure Titanium Subjected to Aluminization and Coated with a Microarc Oxidation Ceramic Coating, *International journal of electrochemical science*, vol. 10, pp. 4290–4302.
- [21] H. Adam, (1997). Carbon fibre in automotive applications, *Materials & design*, vol. 18, no. 4–6, pp. 349–355.

- [22] K. Friedrich and A. A. Almajid, (2013). Manufacturing aspects of advanced polymer composites for automotive applications, *Applied Composite Materials*, vol. 20, no. 2, pp. 107–128.
- [23] A. R. A. Hamid and T. Jagan, (2019). Design and Analysis of Carbon Fibre Composite Monorack Arm for Motorcycle', *International Journal of Integrated Engineering*, vol. 11, no. 7, pp. 152–161.
- [24] A. Elmarakbi, (2013). *Advanced composite materials for automotive applications: Structural integrity and crashworthiness*. John Wiley & Sons.
- [25] J. A. Buckley, G. H. Hinkens, and K. Johnson, (1999). Bicycle brake system.
- [26] C. S. Jones, (2008). Bicycle brake pad.
- [27] M. Kubota, T. Hamabe, Y. Nakazono, M. Fukuda, and K. Doi, (2000). Development of a lightweight brake disc rotor: a design approach for achieving an optimum thermal, vibration and weight balance, *JSAE review*, vol. 21, no. 3, pp. 349–355.
- [28] Y. Sugano, R. Chiba, K. Hirose, and K. Takahashi, (2004). Material Design for Reduction of Thermal Stress in a Functionally Graded Material Rotating Disk, *JSME International Journal Series A Solid Mechanics and Material Engineering*, vol. 47, no. 2, pp. 189–197.
- [29] P. Kraus, J. Úradníček, M. Musil, and M. Bachratý, (2018). Effective Thermo-Structural Analysis for Disc Brake System Simulation', *Strojnícky časopis–Journal of Mechanical Engineering*, vol. 68, no. 2, pp. 125–130.
- [30] 'Composites in Automotive Applications: Review on brake pads and discs - Google Search'. [Online]. Available: <https://www.bristol.ac.uk/engineering/media/accis/cdt/news/aza.pdf>. [Accessed: 25-Jun-2019].
- [31] M. Elkington, D. Bloom, C. Ward, A. Chatzimichali, and K. Potter, (2015). Hand layup: understanding the manual process, *Advanced Manufacturing: Polymer & Composites Science*, vol. 1, no. 3, pp. 138–151.
- [32] 'Beginner's Guide to Wheel Sizing - Evans Cycles - Google Search'. [Online]. Available: <https://www.evanscycles.com/coffeestop/advice/beginners-guide-to-wheel-sizing-and-measurements>. [Accessed: 25-Jun-2019].
- [33] D. Mitroi, 'Centerlock or six bolts?'
- [34] 'The European CEN Standard For Bicycles (updated for 2010)', *Bike Europe*. [Online]. Available: <https://www.bike-eu.com/laws-regulations>. [Accessed: 25-Jun-2019].
- [35] E. Junior, J. A. Lewis, F. E. Arrieche, and L. Schaeffer, (2008). Analysis of wear in organic and sintered friction materials used in small wind energy converters', *Materials Research*, vol. 11, no. 3, pp. 269–273.
- [36] 'CES Edupack 2018. Cambridge United Kingdom: Granta - Google Search'. [Online]. Available: <https://grantadesign.com/education/ces-edupack/>. [Accessed: 25-Jun-2019].