

# Evaluating the Potential of Green Roofs Incorporating Coconut Waste for Climate Change Adaptation

Noor Suraya Romali<sup>1\*</sup>, Vishwas A. Sawant<sup>2</sup>

<sup>1</sup> Faculty of Civil Engineering Technology, Universiti Malaysia Pahang Al-Sultan Abdullah, Lebuhr Persiaran Tun Khalil Yaakob, 26300, Kuantan, Pahang, MALAYSIA

<sup>2</sup> Department of Civil Engineering, Indian Institute of Technology Roorkee, INDIA

\*Corresponding Author: [suraya@ump.edu.my](mailto:suraya@ump.edu.my)

DOI: <https://doi.org/10.30880/ijie.2025.17.09.030>

## Article Info

Received: 19 May 2025

Accepted: 13 November 2025

Available online: 31 December 2025

## Keywords

Green roofs, recycled waste, coconut waste, stormwater management, climate change mitigation

## Abstract

Climate change is a pressing global issue demanding urgent attention due to its widespread impacts. Green roofs present a promising solution by improving stormwater management, enhancing thermal regulation, and promoting sustainability. Yet, their adoption in Malaysian buildings remains limited. The lack of recycled waste utilization also reflects a missed opportunity for sustainable innovation. Coconut waste, abundantly available in Malaysia, remains unexploited despite its potential as a green infrastructure component. Hence, experimental investigations were conducted using three roof models: a conventional roof, a green roof constructed with commercial materials, and a green roof incorporating recycled waste. In the recycled waste-based green roof, coconut shells were used as the drainage layer, while coconut fibers served as the filter layer. Results showed that the recycled waste green roof outperformed the commercial green roof, reducing peak flow by up to 46%, compared to 19–31% for the commercial green roof. It also enhanced stormwater quality, achieving a 45% reduction in biochemical oxygen demand (BOD), while the commercial green roof achieved only 5%. Additionally, vegetated roofs helped lower temperatures, with reductions ranging from 6.45% to 11.48% for the commercial green roof and from 14.75% to 16.13% for the recycled waste green roof, compared to the conventional roof. These findings highlight the potential of green roofs, particularly those utilizing recycled waste materials, as a sustainable solution for urban climate adaptation. Increased adoption of such systems can help to address environmental challenges while promoting the circular use of waste materials.

## 1. Introduction

Climate change is characterized by the frequent and intensified occurrence of extreme weather events, climate-related natural disasters, and gradual climatic and environmental changes. The environmental impacts of climate change include rising temperatures, deterioration of the management of runoff water, reduction in the quality of water and air, and the urban heat island (UHI) effects [1] – [3]. Rapid urbanization is believed to increase the impact of climate change, making people more vulnerable to numerous environmental problems. In this 21<sup>st</sup> century, climate change has impacted billions of people worldwide, including in Malaysia. Malaysia has a tropical climate all year round, and it experiences hot weather and heavy rainfall during the monsoon season. Moreover, impermeable areas have expanded, other areas have been extensively deforested, and many green zones have

This is an open access article under the CC BY-NC-SA 4.0 license.



been lost due to increasing city populations and growing urbanization [4]. The impact of climate change and urbanization provides a clear reason to improve stormwater management systems since phenomena like UHI are hotter than rural areas [5]. Furthermore, Malaysia often experiences periods of torrential rain, which causes major drainage system issues as drains may not be able to manage peak runoff volumes efficiently over short periods. Meanwhile, the high concentrations of pollutants in heavy urban rainfall are particularly hazardous to human health.

Green roofs have been introduced in many countries and work as source control measures as they have the capability to reduce the impacts of climate change [1] – [4], [6]. Green roofs are widely recognized as modern, ecologically sound technological advancements that effectively address climate change-related problems, such as flooding, environmental degradation, and rising temperatures, making them valuable solutions for mitigating environmental issues in urban settings [7] – [9]. A green roof refers to a man-made system installed on the roof of a house or buildings, designed with a structural framework that provides mechanical strength to support the additional load of the green roof layers [10]. A green roof consists of systems of layers which are the membrane for waterproofing, the soil medium for plant growth, and the layer of vegetation. Basically, green roofs are composed of five layers arranged from top to bottom: the vegetation layer, substrate (soil medium), filter layer, drainage layer, and waterproofing layer [7], [11]. Each layer serving a specific function. The topmost vegetation layer features carefully selected plants that help reduce heat absorption, improve air quality, and enhance biodiversity. Beneath it, the substrate (soil medium) supports plant growth by providing nutrients, retaining moisture, and ensuring proper aeration. The filter layer prevents soil particles from clogging the drainage system, allowing only water to pass through. Below this, the drainage layer regulates excess water, preventing waterlogging while maintaining adequate moisture for plant health. Finally, the waterproofing layer at the base acts as a protective barrier, preventing water from penetrating the building structure and ensuring long-term durability [12].

Green roof researchers have recently made considerable attempts to assess and support the urban drainage roles of green roofs, as well as consider how water quality and quantity can best be managed using green roofs. Asman *et al.* [13] and Mendes *et al.* [14] emphasized the effectiveness of green roofs in mitigating rainfall impacts and alleviating pressure on urban drainage systems. The LECA-based green roof used in Mendes *et al.* [14] achieved a remarkable 96.8% reduction in peak runoff, with a peak delay of 14 minutes and a runoff delay ranging from 3.70 to 6.21 minutes, demonstrating its strong hydrological performance. Meanwhile, Dong *et al.* [15] has conducted a study to assess the long-term hydrological performance of a green roof over a 12-year period. Findings showed that the green roof retained 87% of annual precipitation, with 54% lost through evapotranspiration, and achieved mean reductions in runoff volume, peak flow, and flow delay of 82%, 93%, and 4.3 hours, respectively. The effectiveness of green roofs for stormwater quality improvement has also been observed in the studies by Romali *et al.* [16], Akhter *et al.* [17], and Peczkowski *et al.* [18] and Todorov [19]. Meanwhile, the role of green roofs in reduction of Urban Heat Island (UHI) including temperature, thermal and energy reduction can be observed in Li *et al.* [1], Wollschlager *et al.* [7], and Herath *et al.* [20].

Despite the growing interest in green roofs as a sustainable solution for urban environmental challenges, studies on incorporating recycled waste materials into their construction remains limited. Most studies focus on conventional substrates and commercially available materials, overlooking the potential of repurposed waste products to enhance green roof performance while promoting sustainability. The lack of investigation into recycled materials, such as agricultural waste, construction debris, or plastic composites, represents a missed opportunity to reduce environmental pollution and lower material costs. Additionally, integrating recycled waste into green roofs could improve their stormwater retention, thermal insulation, and overall durability, making them more workable for widespread adoption [2], [21], [22]. In tropical countries such as Malaysia, large quantities of coconut waste are generated annually, yet much of it is discarded or underutilized. Coconut shells and fibers possess promising physical and hydraulic properties, including high porosity, permeability, and moisture retention capacity, making them suitable as sustainable substitutes for conventional filter and drainage materials [11]. Addressing this research gap is essential to developing innovative, cost-effective, and eco-friendly green roof systems that align with circular economy principles.

## 1.1 Coconut Waste in Malaysia

Approximately 80,000 tons of coconut waste are dumped annually which is 6.7% of total agricultural waste in Malaysia [23]. Although the majority originates from coconut oil production [24], agricultural waste disposal in landfills has reached more than 1.2 million tonnes per year [23]. The issue arises from the accumulation of coconut waste resulting from heightened consumption, with improper disposal at unauthorized sites exacerbating the problem. This situation gives rise to significant environmental concerns, particularly regarding the endocarp component which necessitates a minimum of ten years for complete degradation. Despite its organic nature, this prolonged decomposition period poses substantial challenges within the realm of agricultural waste management. Notably, the annual disposal of agricultural waste in landfills has surged to over 1.2 million tonnes, with estimates

indicating a staggering 2.843 million tonnes of solid waste deposited in landfills by 2015 alone, averaging 7,986.47 tonnes per day [23].

Malaysia stands as one of the world's foremost coconut producers, resulting in a significant annual output of coconut waste, prominently including coconut shells. The decision to repurpose these shells aligns with a strategic approach to addressing burgeoning waste management challenges while concurrently diminishing the strain on landfill capacities. This move resonates with sustainable waste management practices, steering away from conventional disposal methods and instead harnessing waste as a valuable resource within a circular economic framework. The utilization of coconut shells is intrinsically linked to Malaysia's abundant local resources. Given the country's prolific coconut cultivation, these shells are readily available in substantial quantities. This not only translates into a readily accessible and cost-effective material but also mitigates the need for extensive transportation, thereby lowering associated carbon emissions and reducing the overall environmental impact.

Furthermore, the use of coconut shells aligns well with environmental consciousness and a reduced carbon footprint. The production of coconut shells entails comparably lower carbon emissions compared to alternatives, effectively embodying an environmentally conscious choice that resonates with broader efforts toward sustainable development. This naturally aligns with Malaysia's commitment to eco-friendly practices and responsible resource utilization. Additionally, the innate attributes of coconut shells enhance their suitability for various applications. Their biodegradability presents a distinct advantage over non-biodegradable materials, contributing to a reduction in long-term ecological harm. Moreover, the natural insulation properties of coconut shells and fiber render them suitable for use in construction, exemplified in applications such as green roofs [25], [26]. By integrating coconut shells into prototype scale models for green roofs, Malaysia demonstrates a proactive approach to sustainable urban development, fostering improved microclimates, mitigating urban heat islands, and advancing overall environmental quality [11], [12].

In conclusion, although green roofs are relatively new in Malaysia, they offer significant environmental benefits, particularly in mitigating climate change impacts. This study examined their potential to enhance stormwater management and reduce urban temperatures by incorporating recycled waste as green roof materials. The use of coconut waste demonstrates Malaysia's commitment to sustainability while driving innovation in green infrastructure. By transforming waste into a valuable resource, this approach not only promotes environmentally conscious practices but also fosters community engagement and economic opportunities. Through this integrated strategy, Malaysia positions itself as a leader in sustainable innovation, paving the way for a greener and more resource-efficient future.

## 2. Materials and Methods

### 2.1 Experimental Set-up and Data Collection

Three prototype models were prepared; a conventional non-vegetated roof (control), a commercial green roof, and a recycled waste green roof, as shown in Table 1. The commercial model was prepared using common materials used in the green roof while the recycled waste green roof was constructed using coconut waste such as coconut shell and fibers.

**Table 1** Type of prototype green roof model used in experiment

Model	Description
A	Non-vegetated roof (control)
B	Commercial green roof
C	Recycled waste green roof

The models were designed into two sections, with the upper part used for the green roof area while the lower part acted as the building structure (Fig. 1). The lab-scale prototype models consisted of five layers: vegetation, soil layer (substrate), filter, drainage, and waterproofing. All the prototype models were made of gypsum board and had the same dimensions. Fig. 2(a) and 2(b) illustrate a comparison of the layers used for the commercial and recycled waste green roofs respectively. Both models used Philippines grass (*Zoysia Matrella*) as the vegetation layer and burnt soil was adopted for the soil layer. However, the non-woven geotextile (filter layer) was replaced with coconut fiber in the recycled waste model. Meanwhile, burnt crushed coconut shell acted as the drainage layer in the recycled waste model, replacing the drainage plate that had been used in the commercial model.

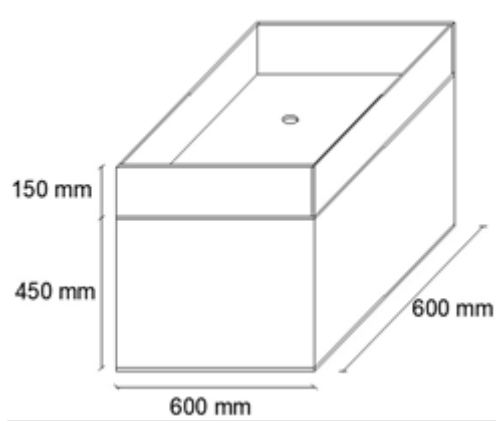

**Fig. 1** Schematic diagram of green roof model

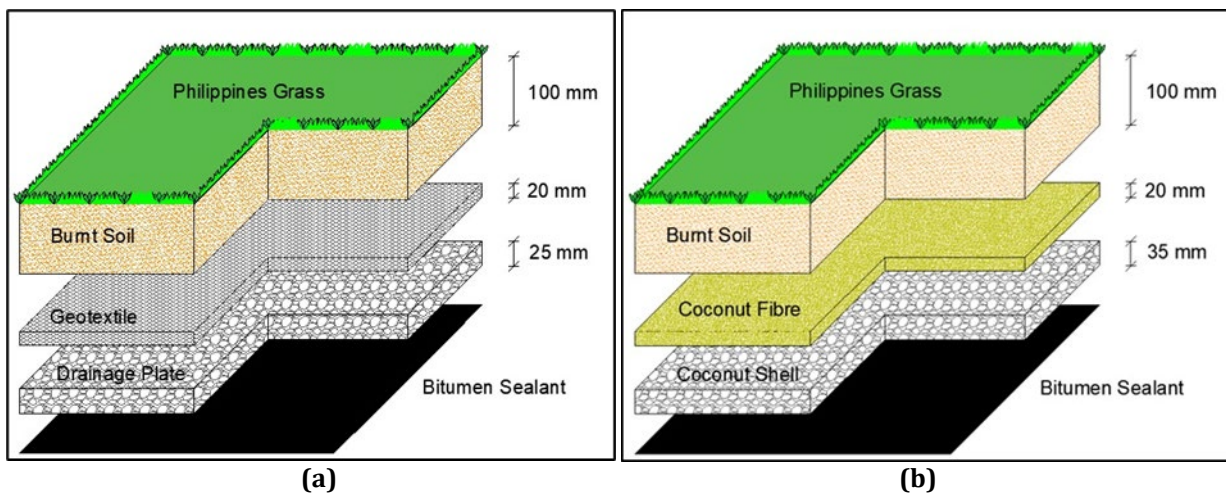

**Fig. 2** Comparison of green roof models: (a) Commercial model; (b) Recycled waste model, illustrating differences in layer configuration and structural composition

Data collection was carried out through two separate events to assess the hydrological and stormwater quality performance of the green roofs. The rainfall water sample was collected at the Centre for Research in Advanced Fluid & Processes (CARiFF) building, University Malaysia Pahang Al Sultan Abdullah (UMPSA), and used for the rainfall simulation process. A rainfall simulator in Hydraulics and Hydrology Laboratory, UMPSA was used to simulate different rainfall intensities of 0.150 and 0.175 mm/min, for Event 1 and Event 2 respectively as shown in Table 2. Each event was conducted with a storm duration of 10 minutes and repeated three times to ensure consistency.

To evaluate the performance of green roof in improving water quality, this study assessed Biochemical Oxygen Demand (BOD), Chemical Oxygen Demand (COD), Dissolved Oxygen (DO), and Total Suspended Solids (TSS) using water runoff samples collected from the three green roof models. Additionally, to assess temperature reduction, temperatures inside and outside the three models were monitored over two weeks, from 2<sup>nd</sup> to 15<sup>th</sup> January 2023.

**Table 2** Details of simulated rainfall events with corresponding rainfall intensities used in the experiment

Event	Rainfall intensity (mm/min)
1	0.150
2	0.175

## 2.2 Evaluation of Green Roof Performance

The experiment was conducted at the Hydraulics and Hydrology Laboratory, UMPSA. A green roof model was placed under a rainfall simulator to simulate water flow and measure stormwater discharge. A hydrograph of discharge ( $\text{m}^3/\text{s}$ ) versus time (s) was plotted, and the hydrological performance was assessed by calculating peak flow reduction using Equation (1).

$$\text{Peak flow reduction} = (1 - Q_v/Q_{nv}) \times 100\% \quad (1)$$

Where  $Q_{nv}$  is the peak flow from the non-vegetated roof (Model A) and  $Q_v$  is the outflow peak rate from the vegetated roof (Model B or C).

To evaluate the performance of green roof models in improving stormwater quality, the percentage reduction of all samples was calculated using Equation (2), where  $C_{nv}$  is the concentration of water quality parameters from the non-vegetated roof (Model A), while  $C_v$  represents the concentration of water quality parameters from the vegetated roof (Model B or C). Sample analysis was conducted at the Environmental Laboratory, Faculty of Civil Engineering Technology, UMPSA.

$$\text{Water quality improvement} = (1 - C_v/C_{nv}) \times 100 \quad (2)$$

The performance of the green roof system in reducing temperature was assessed by monitoring temperature changes inside and outside the prototype building (model). Temperature variations were recorded for the non-vegetated roof (Model A), followed by the vegetated roofs (Model B and C). Data collection was conducted over two weeks, and a thermal reduction graph was plotted against time for all roof types. The percentage of temperature reduction was then calculated using Equation (3), where  $T_{nv}$  is the temperature of the building of the non-vegetated roof (Model A), while  $T_v$  represents the temperature of the building of the vegetated roof (Model B or C).

$$\text{Temperature reduction} = (1 - T_v/T_{nv}) \times 100\% \quad (3)$$

## 2.3 Production of Burnt-Crushed Coconut Shell

The recycled waste material used for the drainage layer was burnt crushed coconut shell. Before being utilized in the green roof system, the raw coconut underwent a processing stage. As shown in Fig. 3, both the coconut shell and coconut fibre were cleaned and air-dried under direct sunlight. The coconut shell was then burnt and crushed into smaller pieces. Finally, the crushed material was sieved using a 2 mm – 5 mm sieve to ensure uniform particle size.



**Fig. 3** Process flow for the production of burnt-crushed coconut shell

### 3. Results and Discussion

#### 3.1 Hydrological Performance Improvement

Figs. 4(a) and 4(b) present the hydrographs of water discharge over time for Events 1 and 2, respectively, comparing the efficiency of green roofs in reducing stormwater runoff. The results indicate that both the commercial and recycled waste green roofs effectively reduced peak flow compared to the control model. Notably, the hydrograph for the recycled waste green roof is the lowest, demonstrating its superior ability to minimize peak runoff. This suggests that incorporating recycled waste materials enhances the hydrological performance of green roofs more effectively than the commercial alternative.

Peak runoff varied among the conventional (control), commercial, and recycled waste green roofs. During Event 1, the control model recorded the highest peak flow at  $13 \times 10^{-5} \text{ m}^3/\text{s}$ , which increased to  $14.17 \times 10^{-5} \text{ m}^3/\text{s}$  in Event 2 due to the application of higher rainfall intensity. In contrast, the recycled waste green roof exhibited the lowest peak flow in Event 1, measuring  $7 \times 10^{-5} \text{ m}^3/\text{s}$ , consistently outperforming the commercial green roof across both rainfall events. A similar trend is observed in Fig. 4(b), where the peak flow of the recycled waste green roof ( $8.83 \times 10^{-5} \text{ m}^3/\text{s}$ ) remains lower than that of the commercial green roof ( $11.5 \times 10^{-5} \text{ m}^3/\text{s}$ ). These results highlight the significant improvement in hydrological performance achieved by incorporating recycled waste materials in green roofs. This improvement could be attributed to the unique physical properties of recycled waste materials, such as higher porosity, increased water retention capacity, and slower drainage rates, which allow for better attenuation of stormwater [22]. These characteristics enable a more gradual release of water, reducing the immediate impact of intense rainfall events and alleviating peak flows in urban drainage systems. The findings align with previous studies by Romali *et al.* [11], Cascone [22] and Petreje *et al.* [27] which have highlighted the potential of alternative green roof substrates in optimizing runoff reduction. Furthermore, the enhanced hydrological performance of recycled waste green roofs indicates the dual benefits of sustainability and functionality. By repurposing waste materials, these green roofs not only improve urban water management but also contribute to circular economy principles and waste reduction efforts [21], [27], [28].

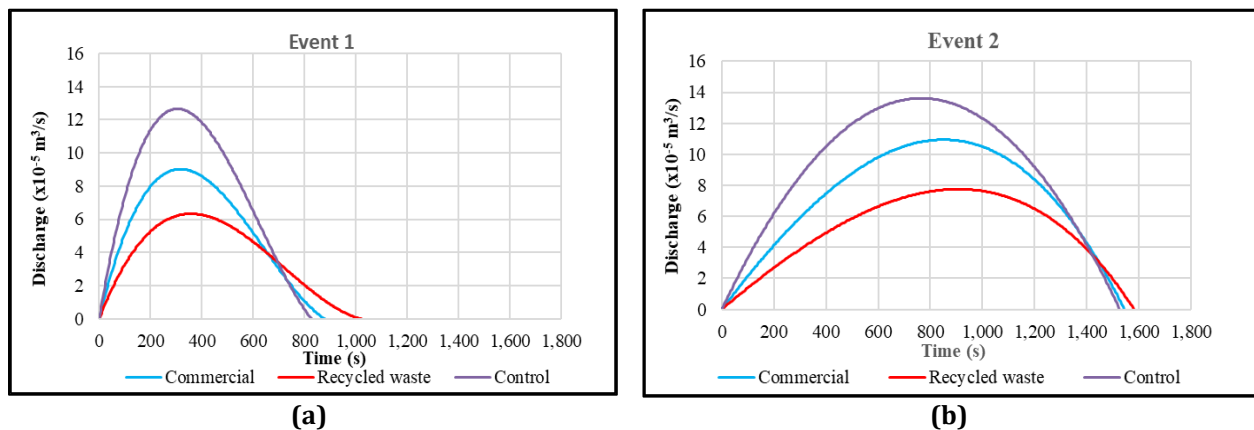
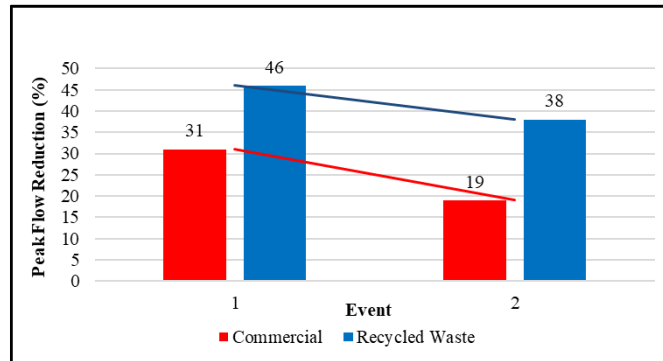

**Fig. 4** Hydrographs comparing variations in peak discharge and time to peak of control, commercial, and recycled waste green roof models under rainfall intensities of (a) 0.150 mm/min; (b) 0.175 mm/min

Fig. 5 depicts the results in terms of peak flow reduction in percentages. The green roof with recycled waste material reduces peak flow better than the commercial by 46% in Event 1 (rainfall intensity 0.150 mm/hr), compared to the commercial model (31%). The similar results were obtained for Event 2 (rainfall intensity 0.175 mm/hr) where the peak flow discharges for the recycled waste green roof model are greater than the commercial which is a 38% reduction from  $14.17 \times 10^{-5} \text{ m}^3/\text{s}$  to  $8.83 \times 10^{-5} \text{ m}^3/\text{s}$ . This result proves the capability of vegetated green roofs in reducing peak runoff, with green roofs utilizing recycled waste exhibiting enhanced performance.

Additionally, the results show a clear trend: as rainfall intensity increases, the effectiveness of green roofs in mitigating runoff decreases. This finding is supported by various studies that highlight the limitations of green roofs under extreme precipitation conditions [11], [29], [30]. Under extreme storm events, which are expected to become more frequent and intense due to climate change, the ability of green roofs to reduce peak flow may be significantly diminished. When rainfall intensity exceeds the substrate's storage and infiltration capacity, rapid saturation occurs, resulting in reduced detention time and higher surface runoff. Consequently, the effectiveness of green roofs in attenuating peak discharge and delaying runoff response decreases [11]. Furthermore, Bose *et al.* [29] suggested that green roofs are more effective in reducing runoff under lower-intensity rainfall but become less efficient as storm intensity increases. For a 2-year storm frequency, runoff reduction ranges from 4% to 16%

at 25% and 75% green roof application rates, respectively, which aligns with the 31%–46% reduction observed in this study for lower-intensity storms. However, for higher-intensity storms (e.g., 25-year frequency), runoff reduction drops to less than 5% at a 25% application rate, comparable to the 19%–38% reduction observed in this study under similar conditions. In conclusion, while green roofs are beneficial for managing stormwater, their effectiveness is significantly compromised during extreme weather events. This limitation raises concerns about their long-term viability as a sustainable urban drainage solution, especially in the context of climate change and increasing rainfall intensity.



**Fig. 5** Peak comparison of peak flow reduction between commercial and recycled waste green roof models for two rainfall events

### 3.2 Stormwater Quality Improvement

Fig. 6 illustrates the water quality concentration prior to and following the use of the green roof system. The BOD and COD concentrations could be improved using the recycled waste model. The volume of oxygen utilized by aerobic bacteria when composing in the water is measured using biochemical oxygen demand (BOD). Samples contain less pollution if the BOD values are lower [29]. The concentration of BOD for the commercial model was 24.85 mg/l, and it slightly decreased for the recycled waste model, which produced a concentration level of 14.33 mg/l. Meanwhile, for the COD parameter, the concentration level for the commercial roof was the highest, at 48 mg/l. The application of the commercial green roof decreased the COD level to 25 mg/l. Furthermore, the COD level for the recycled waste green roof had the lowest concentration of all three roofs, at 23.6 mg/l. Meanwhile, the commercial green roof produced a slight increase in the TSS concentration to 3.75 mg/l, while this rose to 3.86 mg/l with the recycled waste green roof. These results indicate that in discharge water, the content of suspended solids is significantly influenced when recycled waste materials are used. The TSS results showed slight agreement with the work of Mucha *et al.* [32], whereby the TSS in the throughflow from the green roof was higher than that of the control roof.

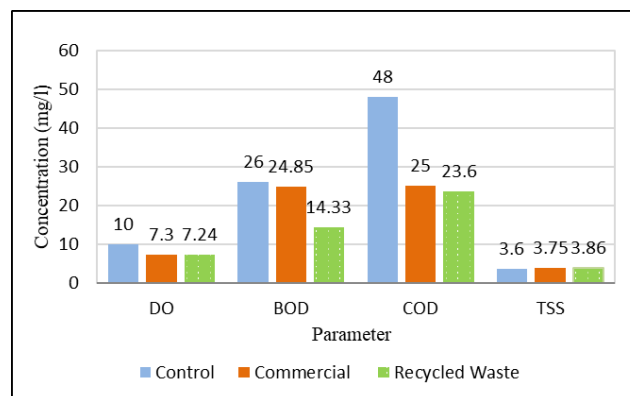

**Fig. 6** Comparison of water quality parameters (DO, BOD, COD, and TSS) for control, commercial, and recycled waste green roof models

Table 3 highlights that green roofs significantly improve BOD and COD concentration. The recycled waste green roof achieved a percentage reduction of 45% for BOD and 51% for COD. It also can be observed that there was a 48% COD improvement for the commercial green roof. Nevertheless, neither the commercial nor recycled waste green roofs appeared to reduce the concentrations of the TSS parameter. The findings suggest that the TSS

concentration would not be improved by using a green roof. However, there was little difference between the three roof types when the TSS concentration results were compared. In conclusion, the findings indicate that concentration improvement is higher when using a recycled waste green roof, ranging between 28% and 51%, compared to 5% to 48% for commercial materials. This is supported by the study by Petreje *et al.* [27], Shukla *et al.* [28] and Liao *et al.* [33], which also reported similar findings.

**Table 3** Water quality improvement in percentages for commercial (Model B) and recycled waste (Model C) green roof models

Water quality parameters	Water quality improvement (%)	
	Model B	Model C
COD	48	51
BOD	5	45
DO	27	28

### 3.3 Temperature Reduction

Recently, the application of green roofs to mitigate the impact of urban heat islands (UHI) has gained increasing attention from researchers [1], [3], [7], [20]. This study contributes to these efforts by providing new findings on temperature reduction. Figs. 7(a) and 7(b) compare the effectiveness of green roofs in mitigating the effects of UHI by depicting temperature data plotted against time for the exterior and interior of the building respectively, over the first week.

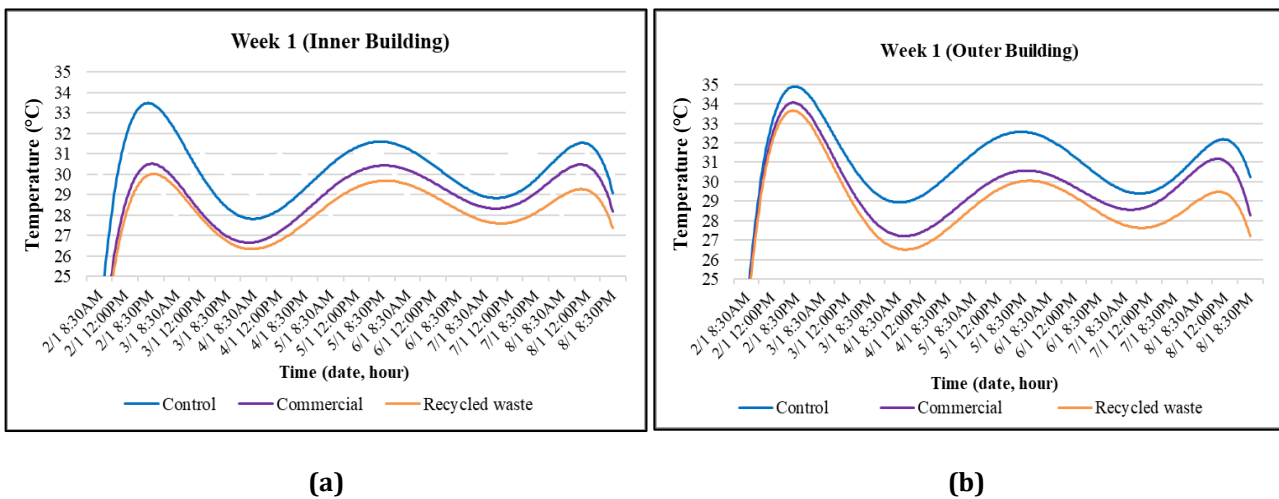
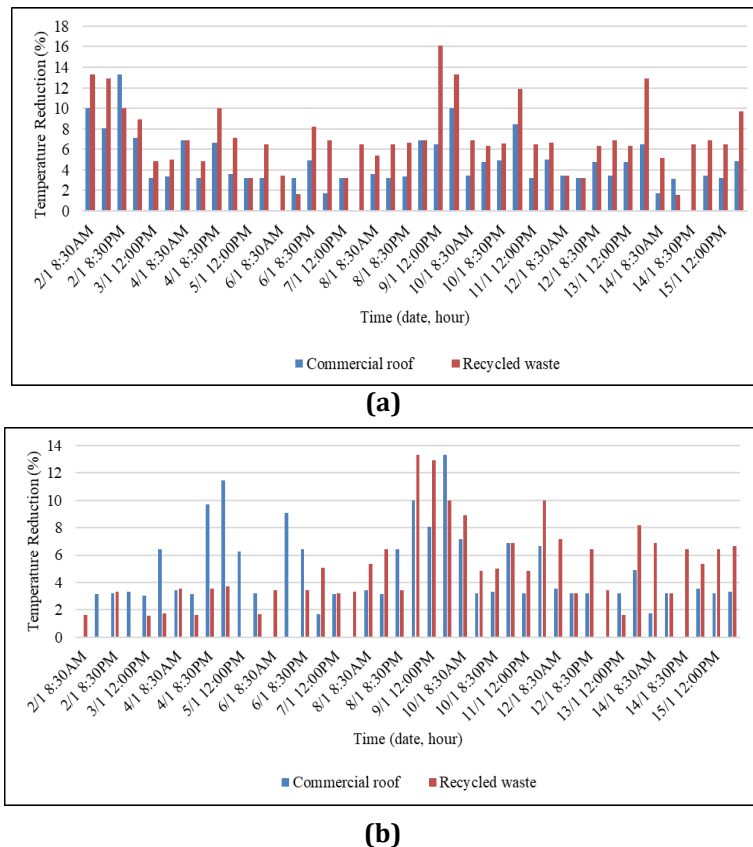

**Fig. 7** Comparison of temperature variation for (a) inner; (b) outer building sections of the green roof models for Week 1

The peak temperatures of control, commercial, and recycled waste green roofs were all found to be different. Green roofs that incorporate recycled materials have greater potential for heat reduction than commercial green roofs, aligned with other study's findings in Schmid *et al.* [2]. At midday on January 2, the control model registered a maximum temperature of 33.5°C for inner building. The temperature on commercial roofs is lower (30.5°C), and on the same time, 30°C was recorded in the recycled waste model. The same trend is observed for other days where the inside of the building where the decreasing temperature for recycled waste is more consistent than it is for commercial and control roofs. The same pattern of results is also noticed for the outer of the structure as shown in Fig. 7(b). On 2 January at noon, the peak temperature is recorded for control roof which is 35°C followed with commercial roof (34°C) and the lowest is recycled waste (33.5°C).

Figs. 8(a) and 8(b) depict the percentages of the temperature reduction for each model at the inner and outer observation points, respectively. The heat decrease achieved by commercial and recycled waste green roofs is compared. Commercial green roofs were found to be effective in mitigating the effects of rising temperature, with reductions of 6.45% and 11.48%, respectively, measured for the building's interior and exterior. A green roof made from recycled materials performs better from a thermal efficiency standpoint, reducing heating and cooling costs by 16.13% and 14.75%; respectively. Overall, it can be concluded that the recycled waste green roof manages to reduce the building temperature compared to the commercial and control green roof and the temperature in

the inner building is lower compared to the outer. The use of recycled waste material, such as coconut shell and coconut fibre, likely increased the green roof's capacity to reduce heat gain by a substantial margin.



**Fig. 8** Comparison of temperature reduction in percentages for (a) inner; (b) outer green roof model

#### 4. Conclusion

In the current study, an investigation was undertaken of three models representing conventional (non-vegetated), commercial green, and recycled waste green roofs. The aim was to determine the extent to which the impact of climate change could be lessened by using green roofs. In summary, the materials used for the five major component layers of the green roof models would be suitable, especially for recycled waste green roofs, since the utilization of the coconut waste led to promising results, as follows:

- i. Green roofs significantly enhance stormwater hydrological performance, with commercial green roofs reducing peak flow by 19% to 31%. Notably, recycled waste green roofs demonstrate a better performance, achieving a reduction of 38% to 46%, highlighting their effectiveness as a low-cost, sustainable alternative to conventional system. These findings highlight the potential of engineering integrating locally available recycled materials, such as coconut waste, into green roof design to enhance urban drainage resilience, and support climate-adaptive construction practices in tropical regions.
- ii. The integration of recycled waste materials in green roof systems markedly enhances water quality improvement, achieving a 45% reduction in BOD compared to only 5% in commercial systems. In addition, recycled waste green roof shows a better performance in reducing COD where the percentage of reduction is 51% compared to the commercial green roof (48%).
- iii. Besides the compromising results obtained for stormwater improvement, the green roof also shows the potential to assist in the reduction of temperature where the inner and outer temperature at the vegetated roof shows a decrease, which is between 6.45% to 11.48% (commercial) and 14.75% to 16.13% (recycled waste) compared to the unvegetated roof. This enhanced thermal regulation indicates the capacity of recycled-waste green roofs to mitigate heat gain more effectively, contributing to reduced building cooling demand and improved indoor comfort. From an engineering perspective, the incorporation of coconut-based recycled materials not only enhances hydrological and water quality

functions but also provides passive thermal control, reinforcing their role as a holistic nature-based solution for sustainable urban building design.

The study on green roofs presents an effective solution for climate change mitigation, particularly in improving stormwater quantity and quality while reducing urban temperatures. However, the findings are limited by the small scale of the laboratory experiment, which may not fully capture the complexity of real-world conditions. Differences in rainfall distribution, maintenance practices, and environmental exposure between laboratory and field settings could influence the actual hydrological performance of green roofs. Future research should therefore focus on large-scale and long-term field studies to validate laboratory outcomes and assess the durability of recycled waste green roofs under diverse climatic conditions. Additionally, investigating the optimal combination of substrate materials and vegetation types could further enhance their hydrological and thermal performance. Further studies should also consider integrating green roofs with other sustainable urban drainage systems (SUDS) to maximize their stormwater management potential. The development of predictive models to assess the impact of green roofs at larger urban scales would provide valuable insights for policymakers and urban planners. Lastly, evaluating the lifecycle cost analysis, including the socio-economic benefits and cost-effectiveness of green roof adoption, particularly those utilizing recycled waste materials, could encourage wider implementation in urban development strategies.

## Acknowledgement

The author sincerely appreciates Universiti Malaysia Pahang Al-Sultan Abdullah (UMPSA) for its financial support through the UMPSA International Publication Research Grant (RDU223312) and the Fundamental Research Grant (RDU210323). Deep gratitude is extended to all Final Year Project students, Nur Atiqah Dasrul, Siti Khairena Khamis, Nur Ashfahani Mohamad Sa'edin, and Nazrul Aizad M Taip, for their contributions to this project. Special thanks also go to the laboratory staff of the Faculty of Civil Engineering Technology, UMPSA, for their technical support and encouragement.

## Conflict of Interest

Authors declare that there is no conflict of interest regarding the publication of the paper.

## Author Contribution

*The authors confirm contribution to the paper as follows: **study conception and design:** Noor Suraya Romali; **data collection:** Noor Suraya Romali; **analysis and interpretation of results:** Noor Suraya Romali, Vishwas A. Sawant; **draft manuscript preparation:** Noor Suraya Romali, Vishwas A. Sawant. All authors reviewed the results and approved the final version of the manuscript.*

## References

- [1] Li, Q., Taubenbock, H. & Zhu, X. X. (2025) Identification of the potential for roof greening using remote sensing and deep learning, *Cities*, 159, 105782, <https://doi.org/10.1016/j.cities.2025.105782>
- [2] Schmidt, M., de Souza, S. N. M., Secco, D., Snak, A. & Bassegio, D. (2025) Evaluation of thermal performance in green roofs using recycled construction waste sand as substrate, *Urban Ecosystems*, 28(53), <https://doi.org/10.1007/s11252-024-01614-1>
- [3] Cirrincione, L., Marvuglia, A. & Scaccianoce, G. (2021) Assessing the effectiveness of green roof in enhancing the energy and indoor comfort resilience of urban buildings to climate change: methodology proposal and application, *Building and Environment*, 205, 108198, <https://doi.org/10.1016/j.buildenv.2021.108198>
- [4] Mohammadi, R. (2016) Evaluation on the quality of green roof run off based on nutrients, Master's Thesis, Lahti University of Applied Sciences.
- [5] Suszanowicz, D. & Kolasa-Więcek, A. (2019) The impact of green roofs on the parameters of the environment in urban areas-review, *Atmosphere*, 10(12), 792, <https://doi.org/10.3390/ATMOS10120792>
- [6] Jia, S., Weng, Q., Yoo, C., Xiao, H. & Zhong, Q. (2024) Building energy savings by green roofs and cool roofs in current and future climates *npj Urban Sustainability*, 4(23), <https://doi.org/10.1038/s42949-024-00159-8>
- [7] Wollschlager, N., Schlink, U., Trabitzzsch, R. & Moeller, L. (2024) Weather dynamics affect the long-term thermal and hydrological performance of different green roof designs, *Science of Total Environment*, 957 (2024), 177376, <https://doi.org/10.1016/j.scitotenv.2024.177376>
- [8] Abdul Hamid, N. H., Romali, N. S., & Rahimi A. R. (2023) Key barriers and feasibility of implementing green roofs on buildings in Malaysia, *Buildings* (2023), 13, 2233, <https://doi.org/10.3390/buildings13092233>

- [9] Naranjo, A., Colonia, A., Mesa, J. & Maury-Ramírez, A. (2020) Evaluation of semi-intensive green roofs with drainage layers made out of recycled and reused materials, *Coatings*, 10, 525(2020), <https://doi.org/10.3390/coatings10060525>
- [10] Jim, C. Y. (2017) Green roof evolution through exemplars: germinal prototypes to modern variants, *Sustainable Cities and Society*, 35, 69–82, <https://doi.org/10.1016/j.scs.2017.08.001>
- [11] Romali, N. S., Ardzu, F. A. & Suzany, M. N. (2023) The potential of coconut waste as green roof materials to improve stormwater runoff, *Water Science & Technology*, 87(6), 1515, <https://doi.org/10.2166/wst.2023.060>
- [12] Romali, N. S., Suzany, M. N. & Shahid, K. A. (2023) Green roof for stormwater runoff control: A review, *AIP Conference Proceedings*, 2688, 040001, <https://doi.org/10.1063/5.0111739>
- [13] Asman, N. S. A., Dullah, S., Amaludin, A. E., Matlan, S. J., Ayog, J. L. & Baharum, A. (2019) The hydrological performance investigation of green roof, *Journal of Advanced Research in Engineering Knowledge*, 9(1), 14–25.
- [14] Mendes, A. M., Monteiro, C. M. & Santos, C. (2025) Green roofs hydrological performance and contribution to urban stormwater management, *Water Resources Management*, 39, 1015–1031, <https://doi.org/10.1007/s11269-024-04003-7>
- [15] Dong, Z., Bain, D. J., Buck, J. K. & Ng, C. (2024) Assessment of the long-term hydrological performance of a green roof system in stormwater control, *Journal of Environmental Management*, 370, 122831, <https://doi.org/10.1016/j.jenvman.2024.122831>
- [16] Romali, N. S., Othman, N. S. & Mhd Ramli, N. N. (2021) The application of green roof for stormwater quantity and quality improvement, *IOP Conference Series: Earth and Environmental Science*, 682, 012029, <https://doi.org/10.1088/1755-1315/682/1/012029>
- [17] Akther, M., He, J., Chu, A., Huang, J. & Duin, B. V. (2018) A review of green roof applications for managing urban stormwater in different climatic zones, *Sustainability*, 10(8), 1–28, <https://doi.org/10.3390/su10082864>
- [18] Peczkowski, G., Kowalczyk, T., Szawernoga, K., Orzepowski, W., Zmuda, R. & Pokładek, R. (2018) Hydrological performance and runoff water quality of experimental green roofs, *Water*, 10, 1185, <https://doi.org/10.3390/w10091185>
- [19] Todorov, D. L. (2017) The effectiveness of a constructed vegetated roof for pollutant removal and stormwater source control, PhD Dissertation, Syracuse University.
- [20] Herath, P., Thatcher, M., Jin, H. & Bai, X. (2023) Feasibility of using green roofs and cool roofs for extreme heat mitigation in Melbourne, Australia, in Sameh et al. (eds), *Integrating Resiliency into Future Sustainable Cities*, Springer, Cham, [https://doi.org/10.1007/978-3-031-63203-7\\_14](https://doi.org/10.1007/978-3-031-63203-7_14)
- [21] Yalcinap, E., Demirci, O. & Meral, A. (2025) Brewing sustainability: unveiling the potential of coffee ground as green roof media, *Urban Ecosystems*, 28, 80, <https://doi.org/10.1007/s11252-025-01684-9>
- [22] Cascone, S. (2022) Drainage layer in green roofs: proposal for the use of agricultural plastic waste, in Calabrò et al. (eds), *New Metropolitan Perspectives*, Springer, Cham, [https://doi.org/10.1007/978-3-031-06825-6\\_177](https://doi.org/10.1007/978-3-031-06825-6_177)
- [23] Rosli, T. M. & Jumali, S. S. (2022) Mycoremediation of coconut shell (*Cocos nucifera*) with *Ganoderma lucidum*, *IOP Conference Series: Earth and Environmental Science*, 1059, 012025, <https://doi.org/10.1088/1755-1315/1059/1/012025>
- [24] Sulaiman, S., Abdul Raman, A. A. & Mohamed Aroua, M. K. (2010) Coconut waste as a source for biodiesel production, *2010 2<sup>nd</sup> International Conference on Chemical, Biological and Environmental Engineering*, 254–256, <https://doi.org/10.1109/ICBEE.2010.5653534>
- [25] Araújo de Almeida, M. & Colombo, R. (2021) Construction of green roofs using substrates made from humus and green coconut fiber or sugarcane bagasse, *Sustainable Chemistry and Pharmacy*, 22, 100477.
- [26] Fabbri, K., Tronchin, L. & Barbieri, F. (2021) Coconut fibre insulators: Hydrothermal behaviour in green roofs, *Construction and Building Materials*, 266, 121026.
- [27] Petreje, M., Snehota, M., Chorazy, T., Novotný, M., Rybova, B. & Heckova, P. (2023) Performance study of hybrid constructed wetland–extensive green roof with recycled materials, *Journal of Environmental Management*, 331, 117151, <https://doi.org/10.1016/j.jenvman.2022.117151>

- [28] Shukla, B. K. et al. (2024) Sustainable construction practices with recycled and waste materials for a circular economy, *Asian Journal of Civil Engineering*, 25, 5255–5276, <https://doi.org/10.1007/s42107-024-01111-y>
- [29] Bose, T., Kalbar, P. P. & Mondal, A. (2024) Performance and uncertainty assessment of green roofs for urban flood reduction in Ahmedabad, India, *Journal of Environmental Management*, 365, 121500, <https://doi.org/10.1016/j.jenvman.2024.121500>
- [30] Chen, P. Y., Hong, X. F. & Lo, W. H. (2024) Evaluating stormwater reduction of a green roof under varied rainfall events and antecedent water content, *Ecohydrology & Hydrobiology*, 24, 112–127, <https://doi.org/10.1016/j.ecohyd.2023.12.002>
- [31] Chow, M. F. & Ahmad Azlan, A. A. (2020) Assessing the performance of bio compost as soil media in extensive green roof, *IOP Conference Series: Materials Science and Engineering*, 713, 012012, <https://doi.org/10.1088/1757-899X/713/1/012012>
- [32] Mucha, S., Williamson, G. & MacAvoy, S. (2020) Pollution reduction in throughflow from vegetated and non-vegetated foam-based surfaces and green roofs, *Nitrogen*, 1(1), 21–33, <https://doi.org/10.3390/nitrogen1010004>
- [33] Liao, W. (2024) Biochar and vegetation effects on discharge water quality from organic-substrate green roofs, *Science of the Total Environment*, 922, 171302, <https://doi.org/10.1016/j.scitotenv.2024.171302>